

Name and Std ID: _____ Lab Section: _____

Date: _____

PRELAB:

Q1. Add the following numbers then write them in decimal:

Binary numbers to add a3 a2 a1 a0 + b3 b2 b1 b0	Binary result C0 S3 S2 S1 S0	Decimal conversion N2 N1 (X3 X2 X1 X0) (X3 X2 X1 X0)
1001 + 0111	10000	16
1011 + 1001		
1110 + 0101		
0010 + 1110		
1101 + 1011		

Q2. Consider the five-bit binary result (C0, S3, S2, S1, S0) representation in the table above. We would like to represent each combination as its equivalent in two decimal digits, each of which can be represented in binary as shown in the following table. Finish filling in the following truth table.

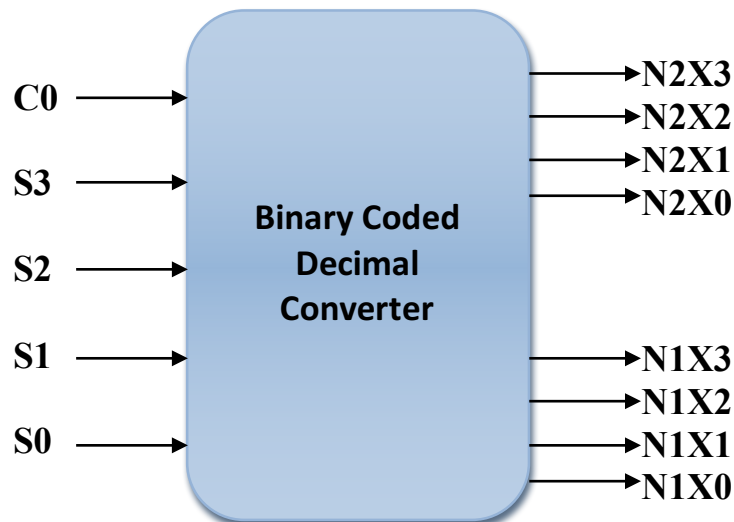

Lab 6 Answer Sheet

C0	S3	S2	S1	S0	Decimal		N2X3	N2X2	N2X1	N2X0	N1X3	N1X2	N1X1	N1X0
0	0	0	0	0	0	0	0	0	0	0	0	0	0	0
0	0	0	0	1	0	1	0	0	0	0	0	0	0	1
0	0	0	1	0	0	2	0	0	0	0	0	0	1	0
0	0	0	1	1	0	3	0	0	0	0	0	0	1	1
0	0	1	0	0	0	4	0	0	0	0	0	1	0	0
0	0	1	0	1	0	5	0	0	0	0	0	1	0	1
0	0	1	1	0	0	6	0	0	0	0	0	1	1	0
0	0	1	1	1	0	7	0	0	0	0	0	1	1	1
0	1	0	0	0	0	8	0	0	0	0	1	0	0	0
0	1	0	0	1	0	9	0	0	0	0	1	0	0	1
0	1	0	1	0	1	0	0	0	0	1	0	0	0	0
0	1	0	1	1	1	1	0	0	0	1	0	0	0	1
0	1	1	0	0	1	2	0	0	0	1	0	0	1	0
0	1	1	0	1	1	3	0	0	0	1	0	0	1	1
0	1	1	1	0	1	4	0	0	0	1	0	1	0	0
0	1	1	1	1	1	5	0	0	0	1	0	1	0	1
1	0	0	0	0	1	6	0	0	0	1	0	1	1	0
1	0	0	0	1										
1	0	0	1	0										
1	0	0	1	1										
1	0	1	0	0										
1	0	1	0	1										
1	0	1	1	0										
1	0	1	1	1										
1	1	0	0	0										
1	1	0	0	1										
1	1	0	1	0										
1	1	0	1	1										
1	1	1	0	0										
1	1	1	0	1										
1	1	1	1	0										
1	1	1	1	1										

Q3. Find the logic expressions for $N2X3$, $N2X2$, $N2X1$, $N2X0$, $N1X3$, $N1X2$, $N1X1$, and $N1X0$ as a function of $C0$, $S3$, $S2$, $S1$ and $S0$:

$N2X3 =$

$N2X2 =$

$N2X1 =$

$N2X0 =$

$N1X3 =$

$N1X2 =$

$N1X1 =$

$N1X0 =$

Q4. Write the verilog code for the Binary Coded Decimal Converter from **Section 3.3** using the assign statement.

Example:

```
module  
    input ...  
    output ...  
    assign ...  
endmodule
```

TA Initials: _____

LAB:

Hardware demonstrates a good design. TA Initials: _____