



# **CprE 281: Digital Logic**

**Instructor: Alexander Stoytchev**

**<http://www.ece.iastate.edu/~alexs/classes/>**

# **Designing a Counter**

## **(Using the Sequential Circuit Approach)**

*CprE 281: Digital Logic*  
*Iowa State University, Ames, IA*  
*Copyright © Alexander Stoytchev*

**Example:**  
**Implement a modulo-8 counter**

# **Mini Review**

# **Asynchronous Counters**

# A three-bit down-counter

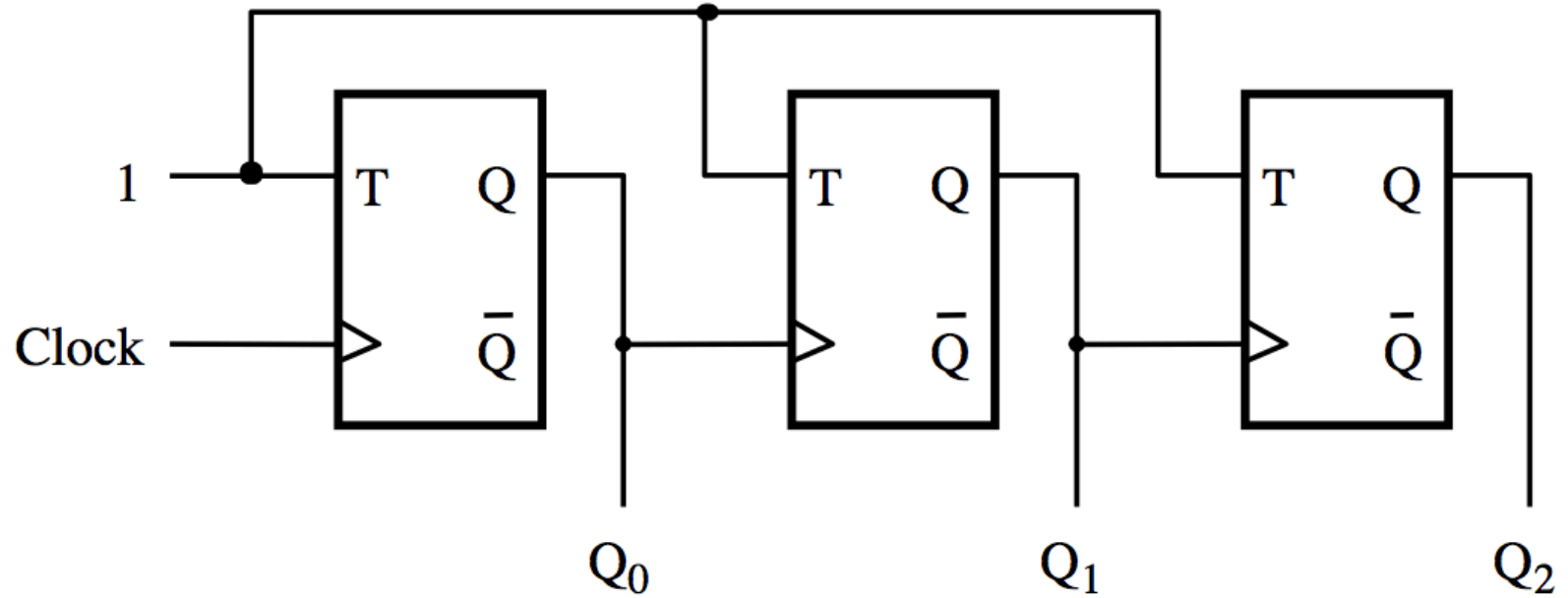

# A three-bit down-counter

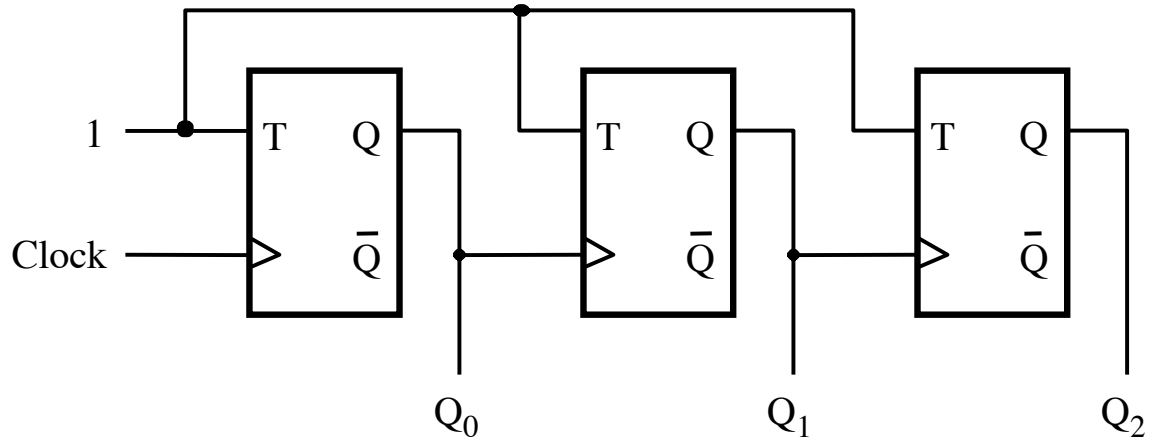

(a) Circuit

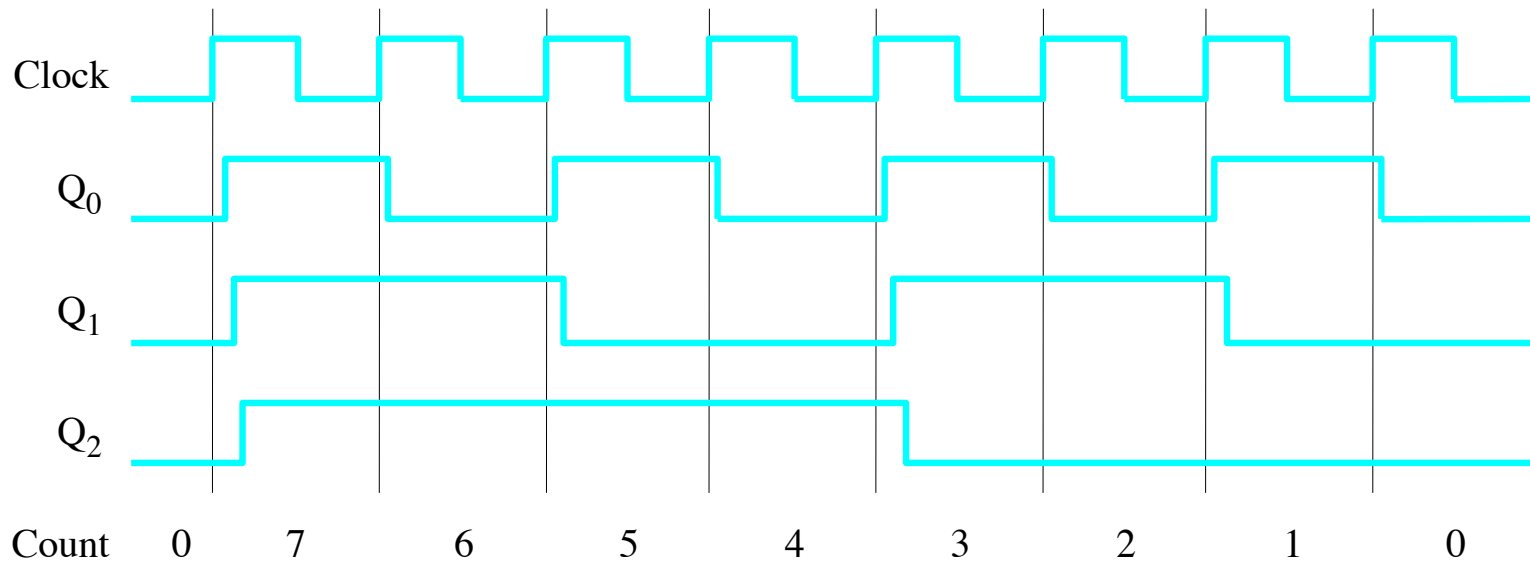

(b) Timing diagram

# A three-bit down-counter

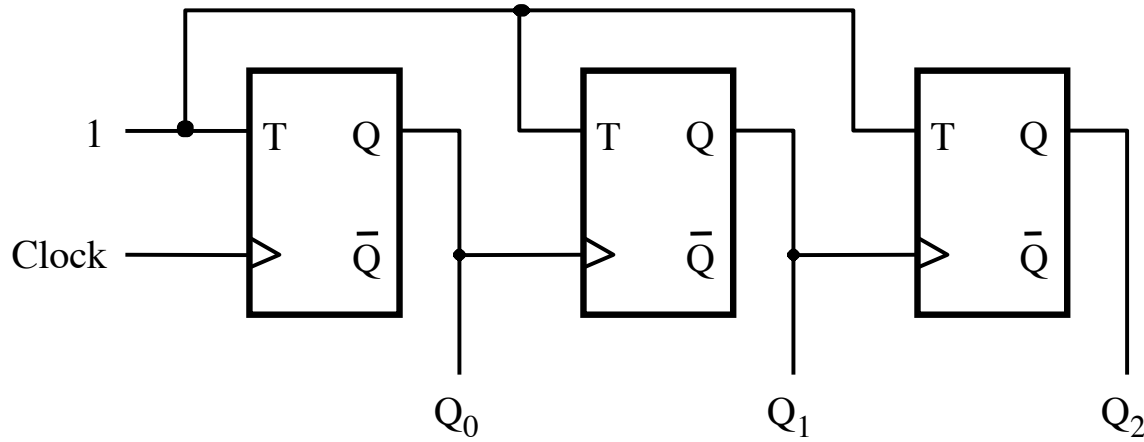

(a) Circuit

The propagation delays get longer

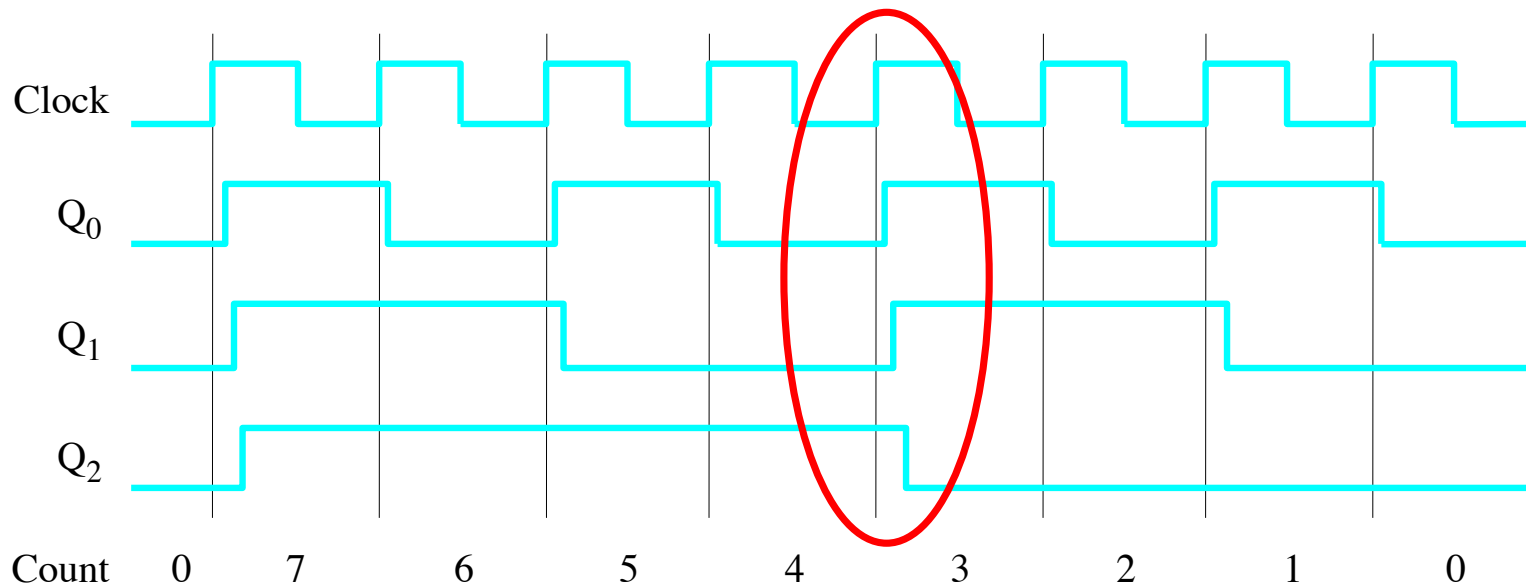

(b) Timing diagram



# A three-bit up-counter

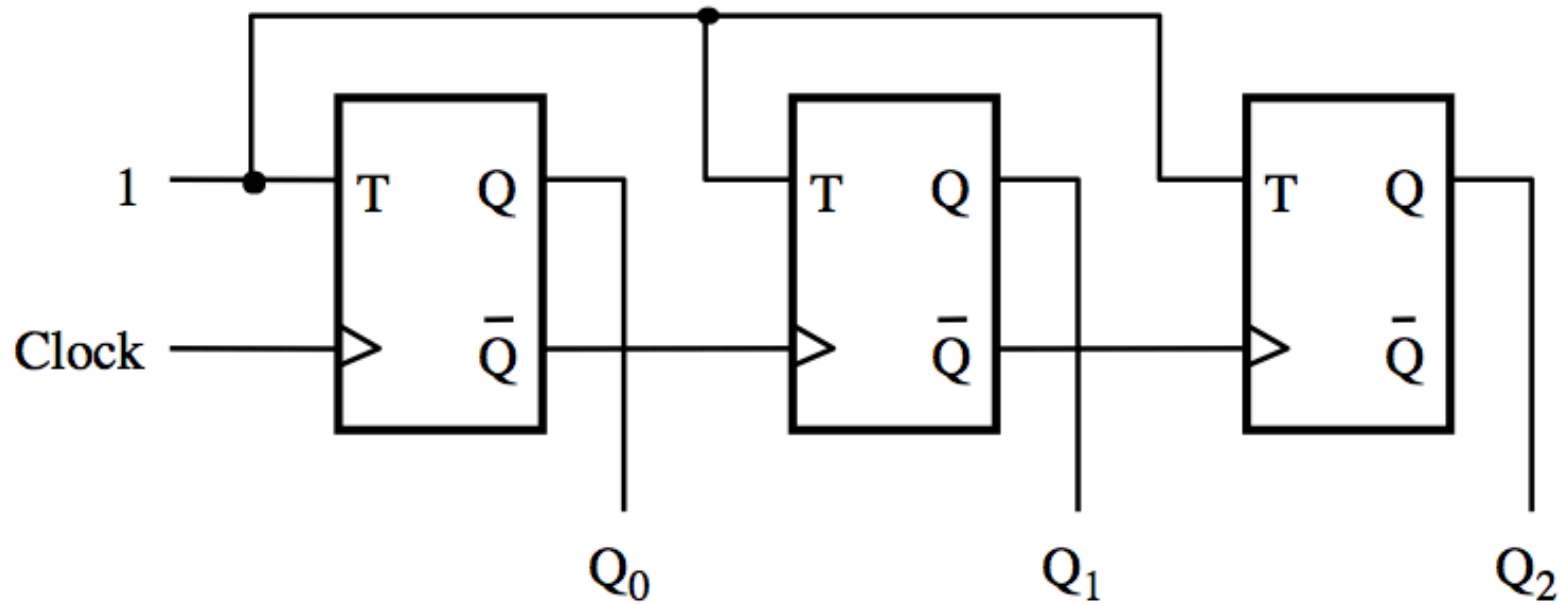

# A three-bit up-counter

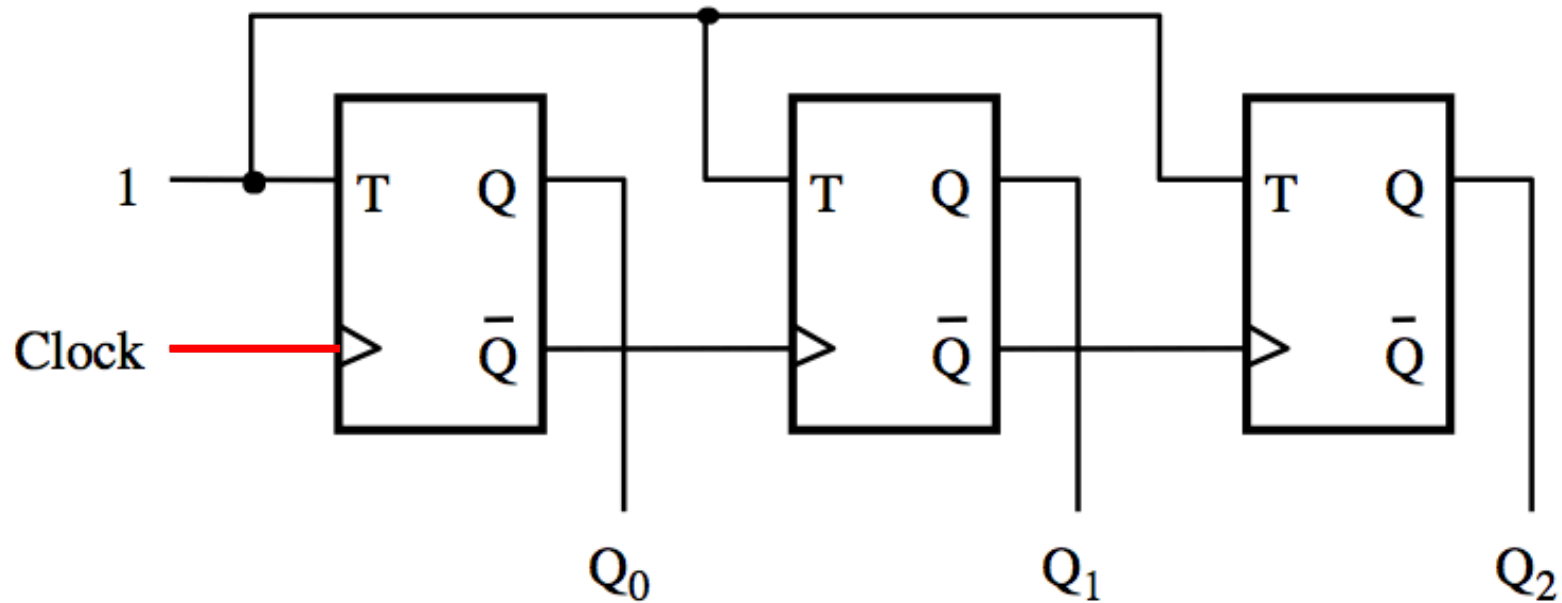

The first flip-flop changes  
on the positive edge of the clock

# A three-bit up-counter

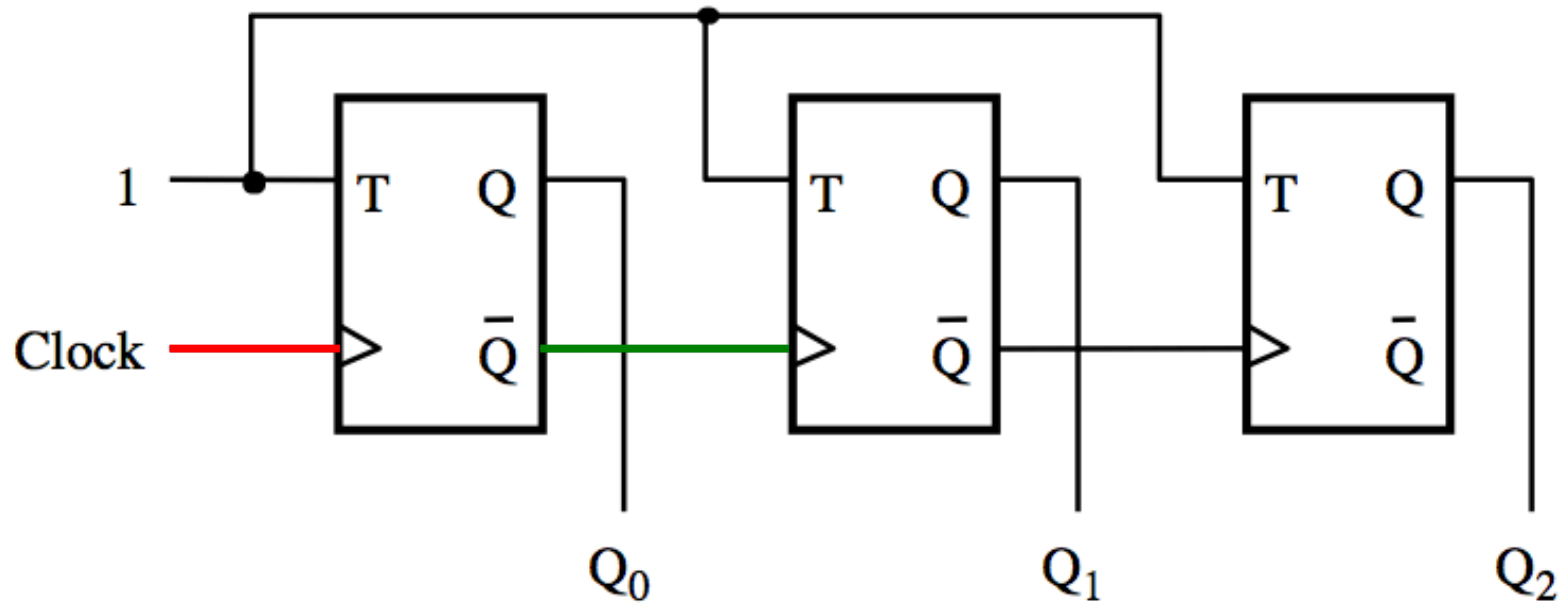

The first flip-flop changes  
on the positive edge of the clock

The second flip-flop changes  
on the positive edge of  $\bar{Q}_0$

# A three-bit up-counter

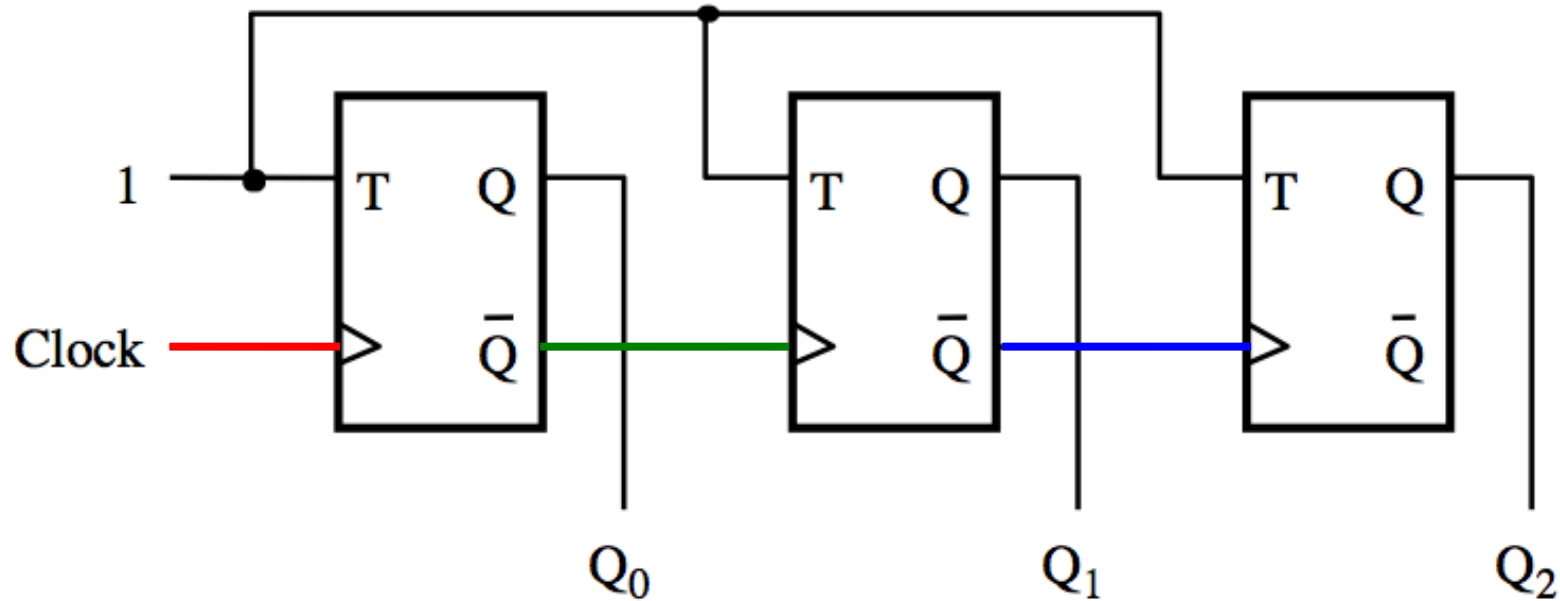

The first flip-flop changes  
on the positive edge of the clock

The second flip-flop changes  
on the positive edge of  $\bar{Q}_0$

The third flip-flop changes  
on the positive edge of  $\bar{Q}_1$

# A three-bit up-counter

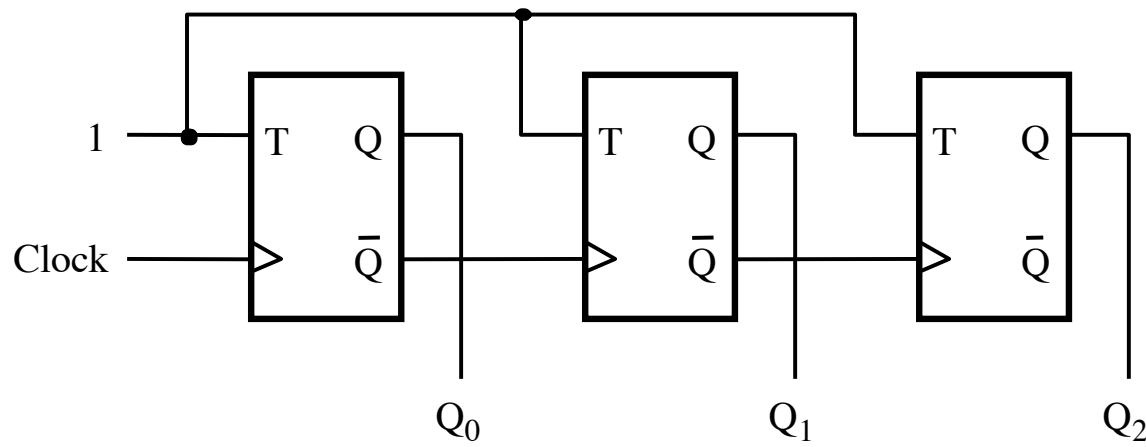

(a) Circuit

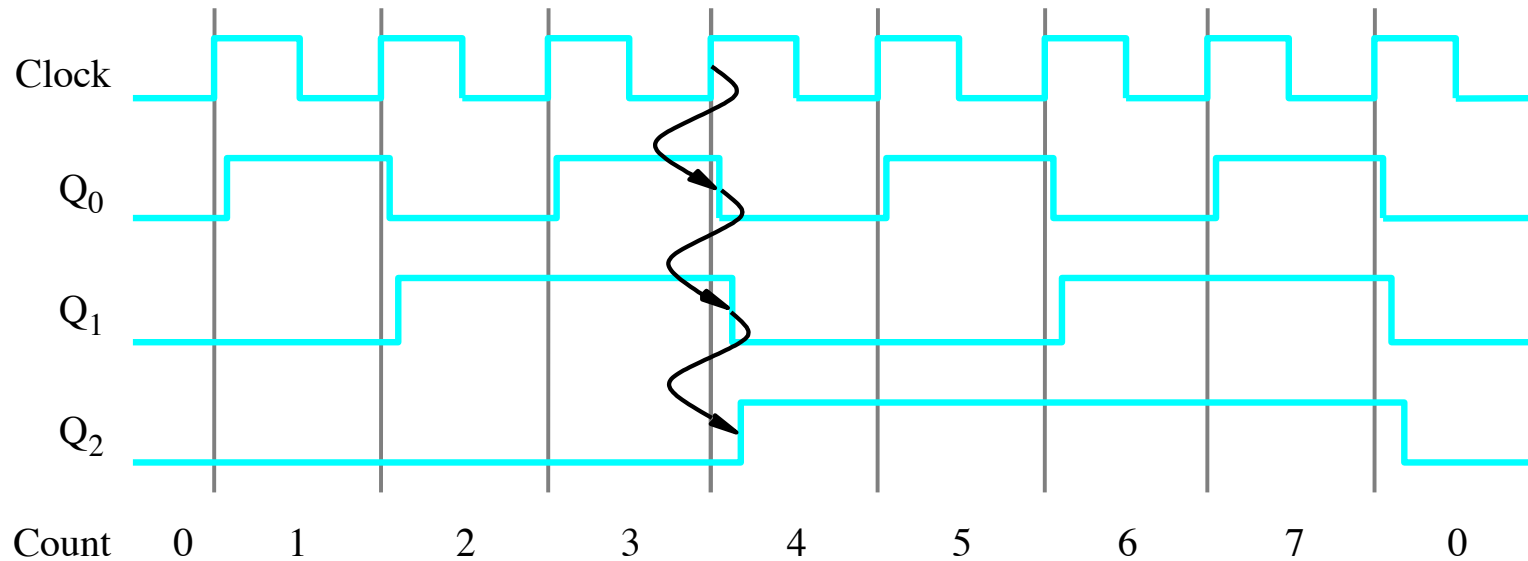

(b) Timing diagram

# A three-bit up-counter

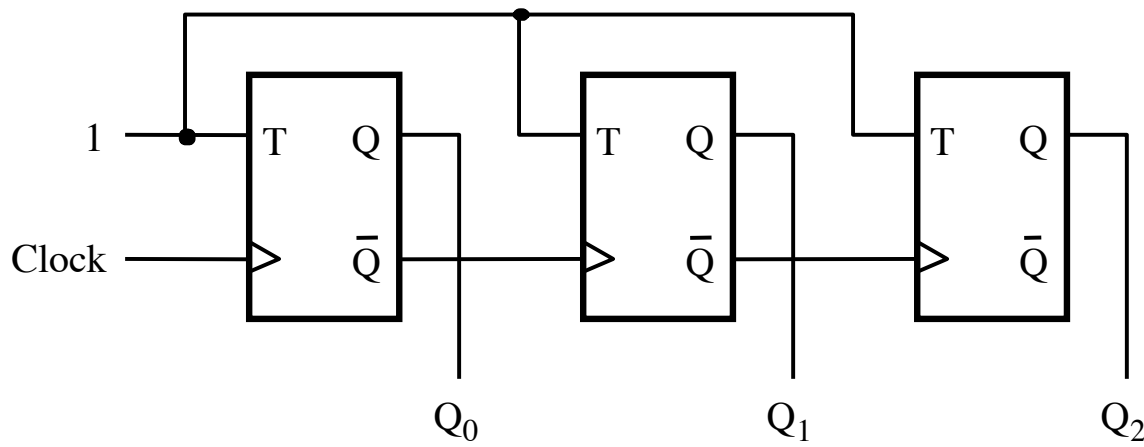

(a) Circuit

The propagation delays get longer

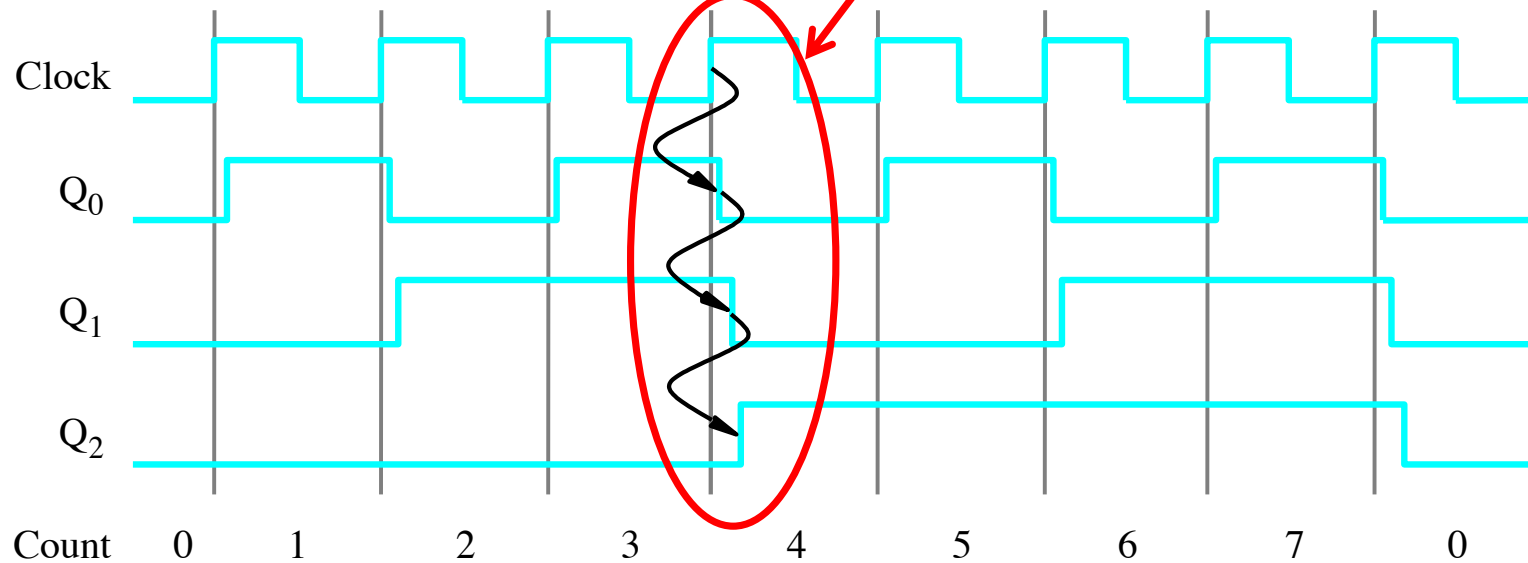

(b) Timing diagram

# **Synchronous Counters**

# A four-bit synchronous up-counter

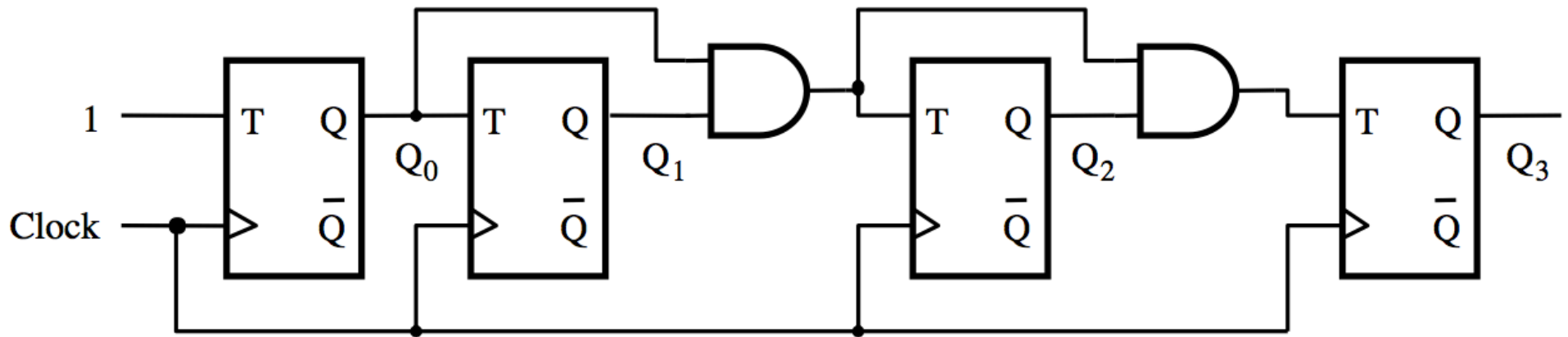



# A four-bit synchronous up-counter

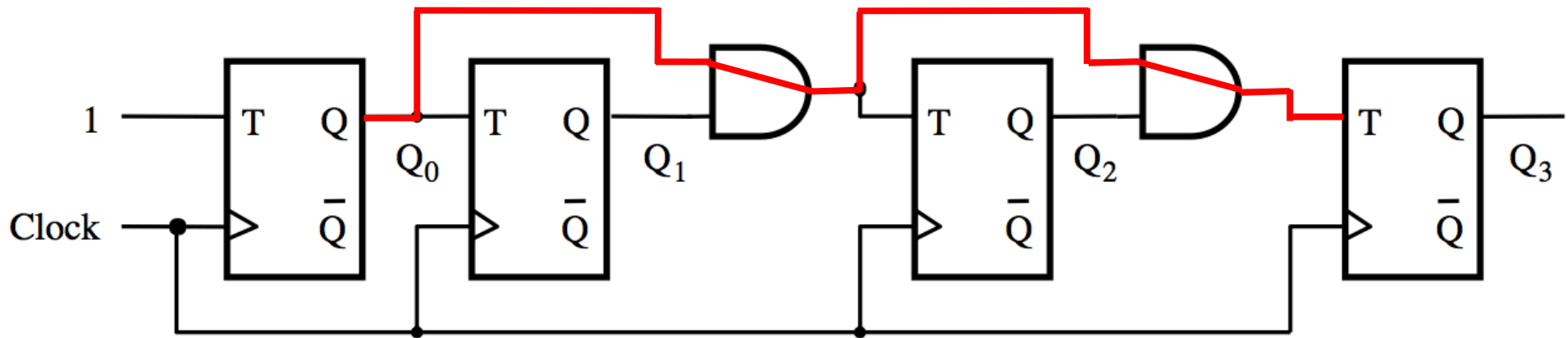

The propagation delay through all AND gates combined must not exceed the clock period minus the setup time for the flip-flops

# A four-bit synchronous up-counter

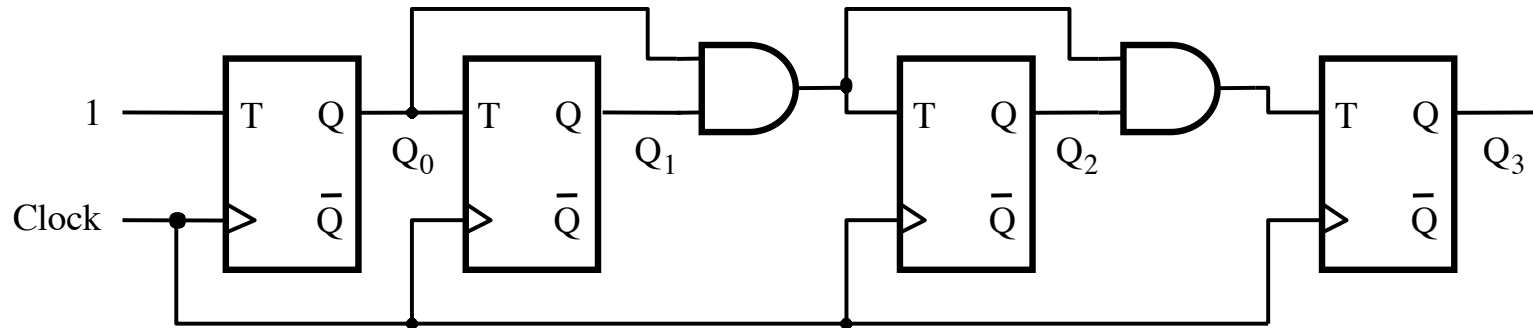

(a) Circuit

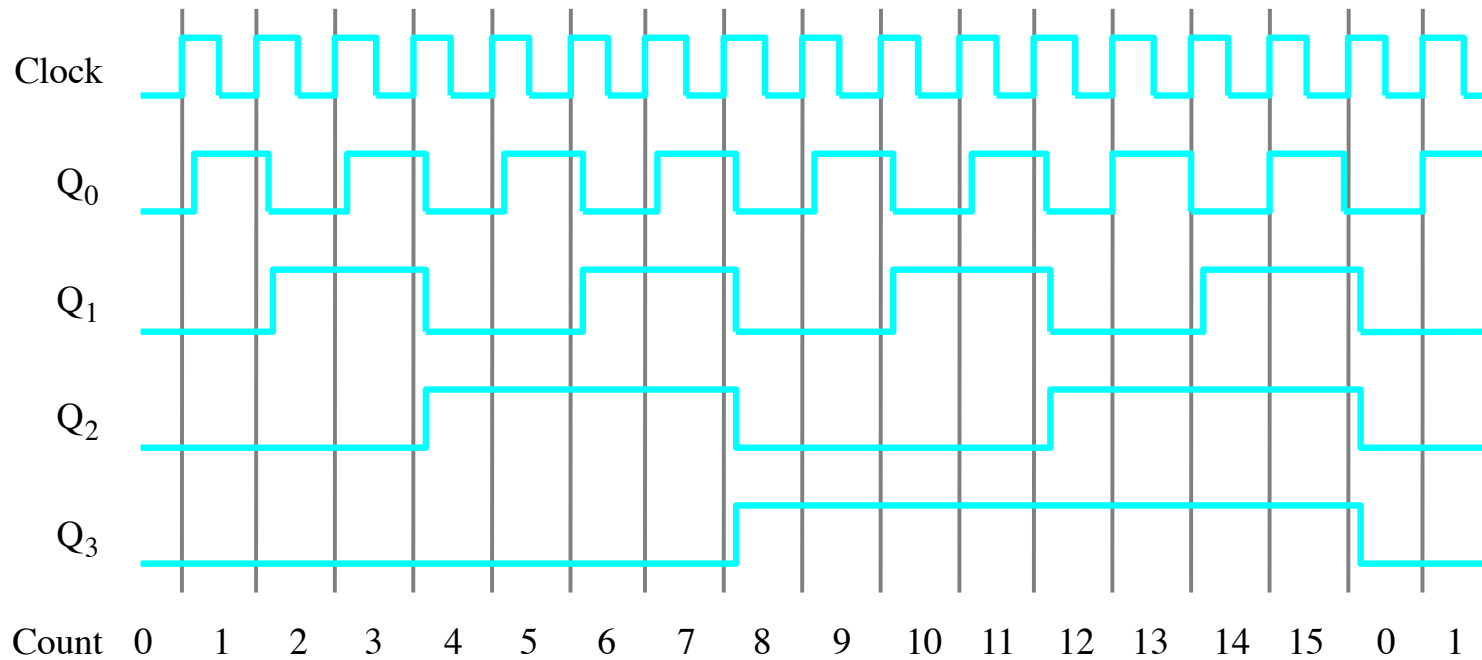

(b) Timing diagram

# Derivation of the synchronous up-counter

Clock cycle	Q <sub>2</sub>	Q <sub>1</sub>	Q <sub>0</sub>
0	0	0	0
1	0	0	1
2	0	1	0
3	0	1	1
4	1	0	0
5	1	0	1
6	1	1	0
7	1	1	1
8	0	0	0

Q<sub>1</sub> changes

Q<sub>2</sub> changes

# Derivation of the synchronous up-counter

Clock cycle	Q <sub>2</sub>	Q <sub>1</sub>	Q <sub>0</sub>
0	0	0	0
1	0	0	1
2	0	1	0
3	0	1	1
4	1	0	0
5	1	0	1
6	1	1	0
7	1	1	1
8	0	0	0

Q<sub>1</sub> changes

Q<sub>2</sub> changes

$$T_0 = 1$$

$$T_1 = Q_0$$

$$T_2 = Q_0 Q_1$$

# A four-bit synchronous up-counter

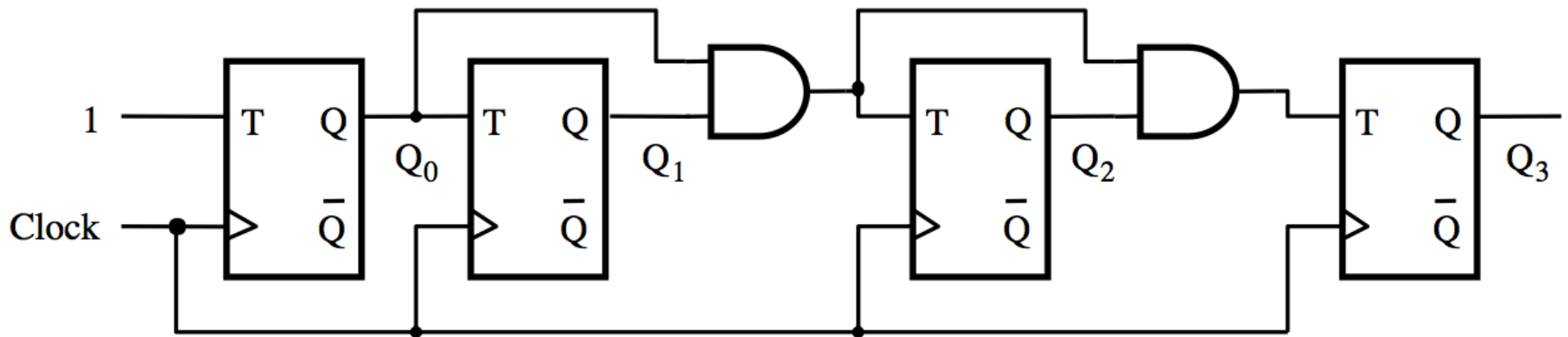

$$T_0 = 1$$

$$T_1 = Q_0$$

$$T_2 = Q_0 Q_1$$

# In general we have

$$T_0 = 1$$

$$T_1 = Q_0$$

$$T_2 = Q_0 Q_1$$

$$T_3 = Q_0 Q_1 Q_2$$

...

$$T_n = Q_0 Q_1 Q_2 \cdots Q_{n-1}$$

# Inclusion of Enable and Clear capability

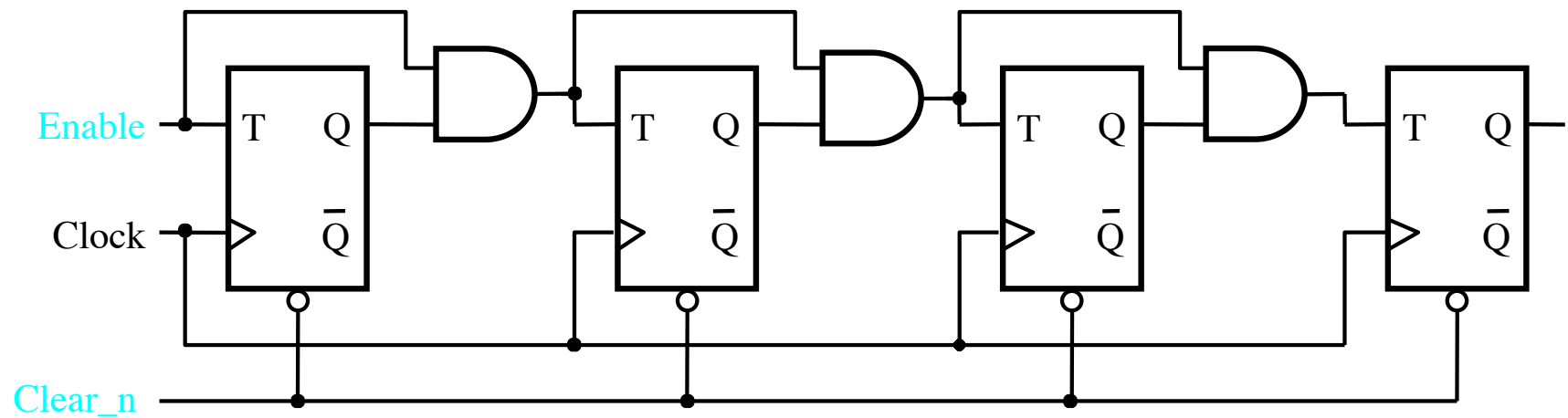

[ Figure 5.22 from the textbook ]

# Inclusion of Enable and Clear capability

This is the new thing relative to the previous figure, plus the clear\_n line

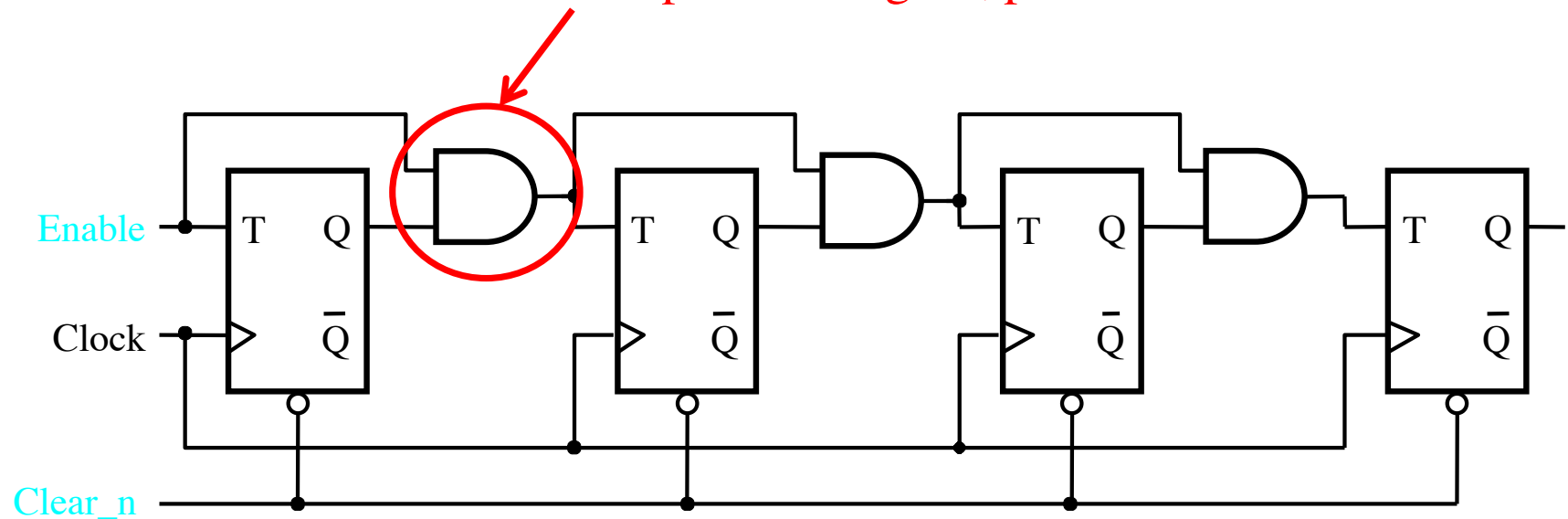



# T Flip-Flop

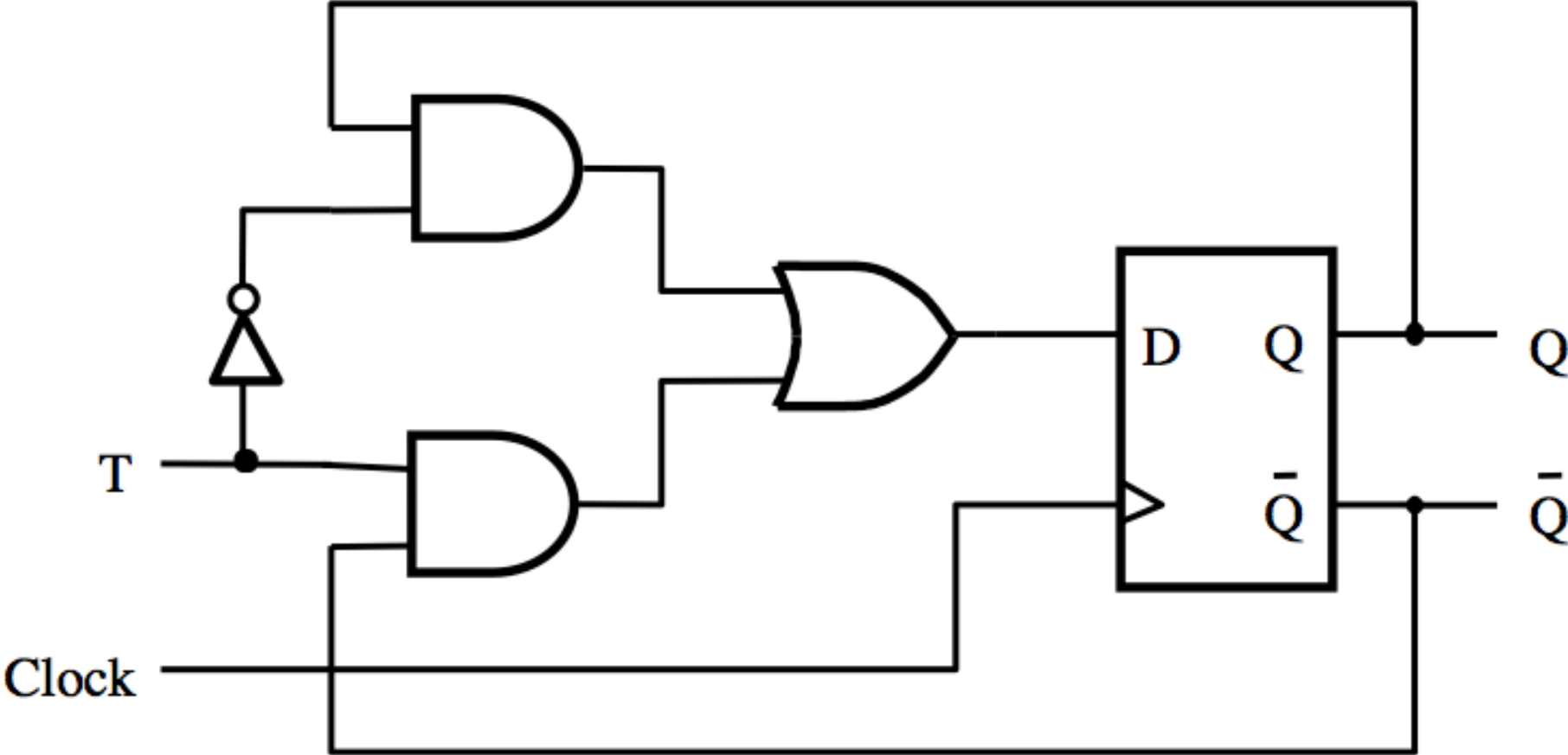

[ Figure 5.15a from the textbook ]

# T Flip-Flop

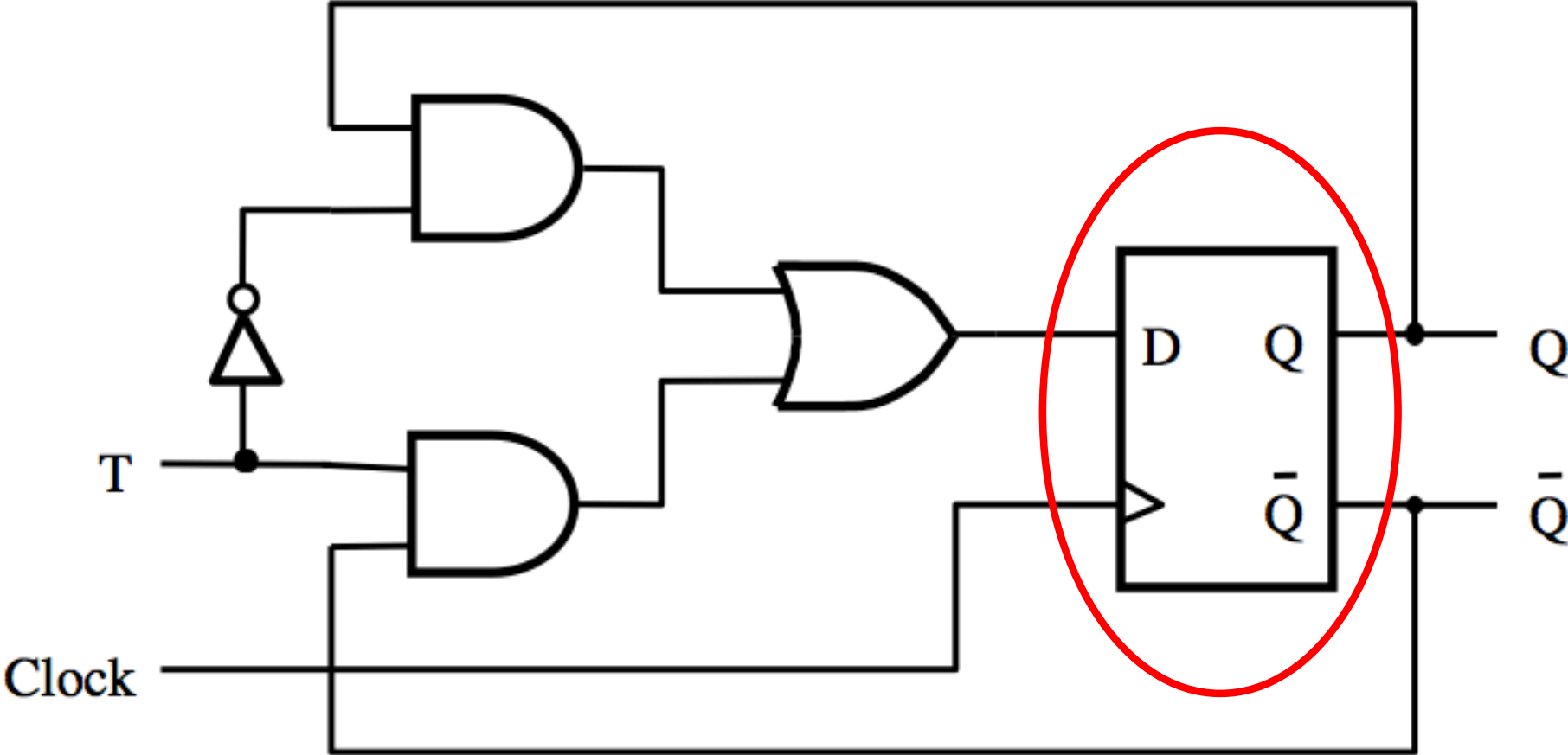

Positive-edge-triggered  
D Flip-Flop

[ Figure 5.15a from the textbook ]

# T Flip-Flop

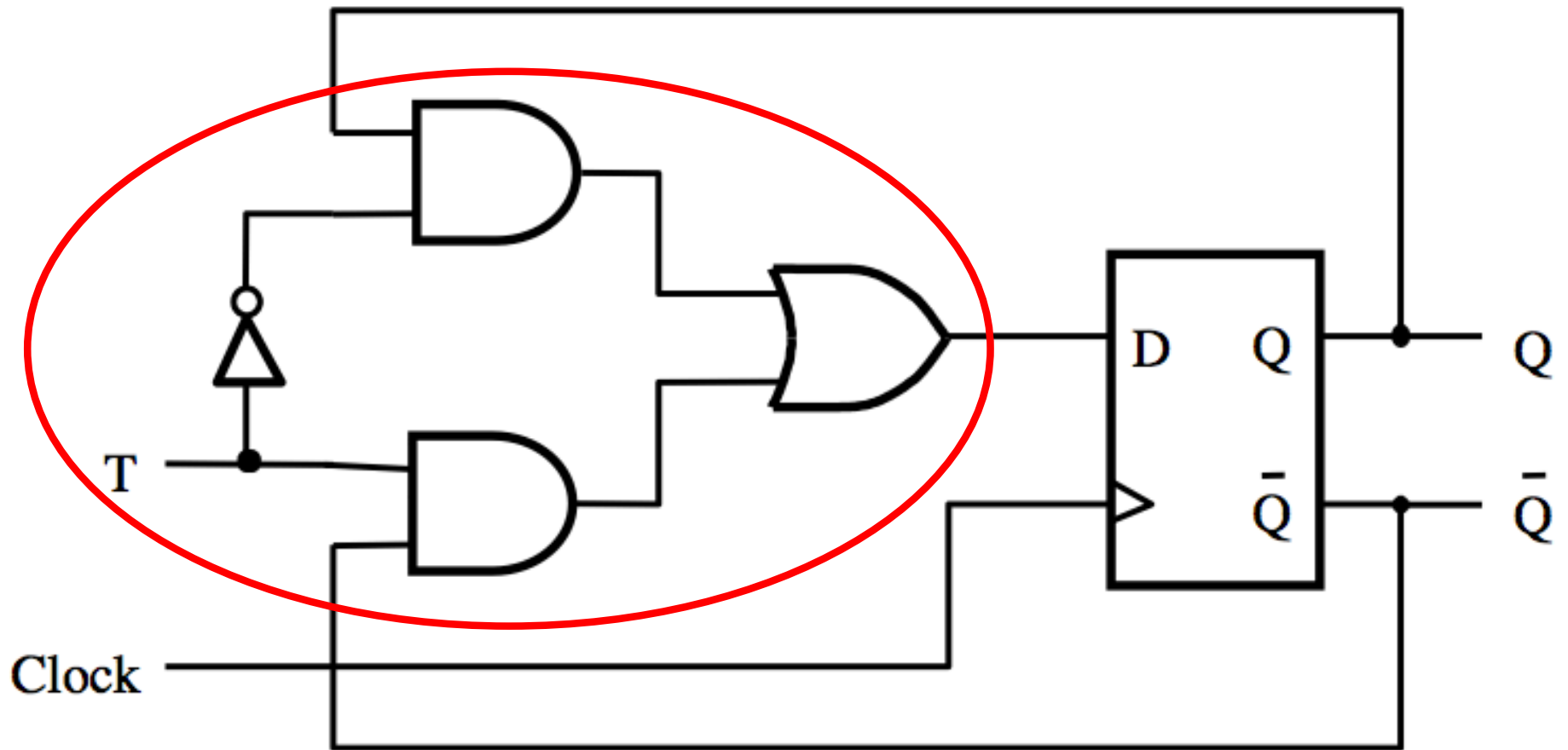

2-to-1 multiplexer

# 2-to-1 Multiplexer

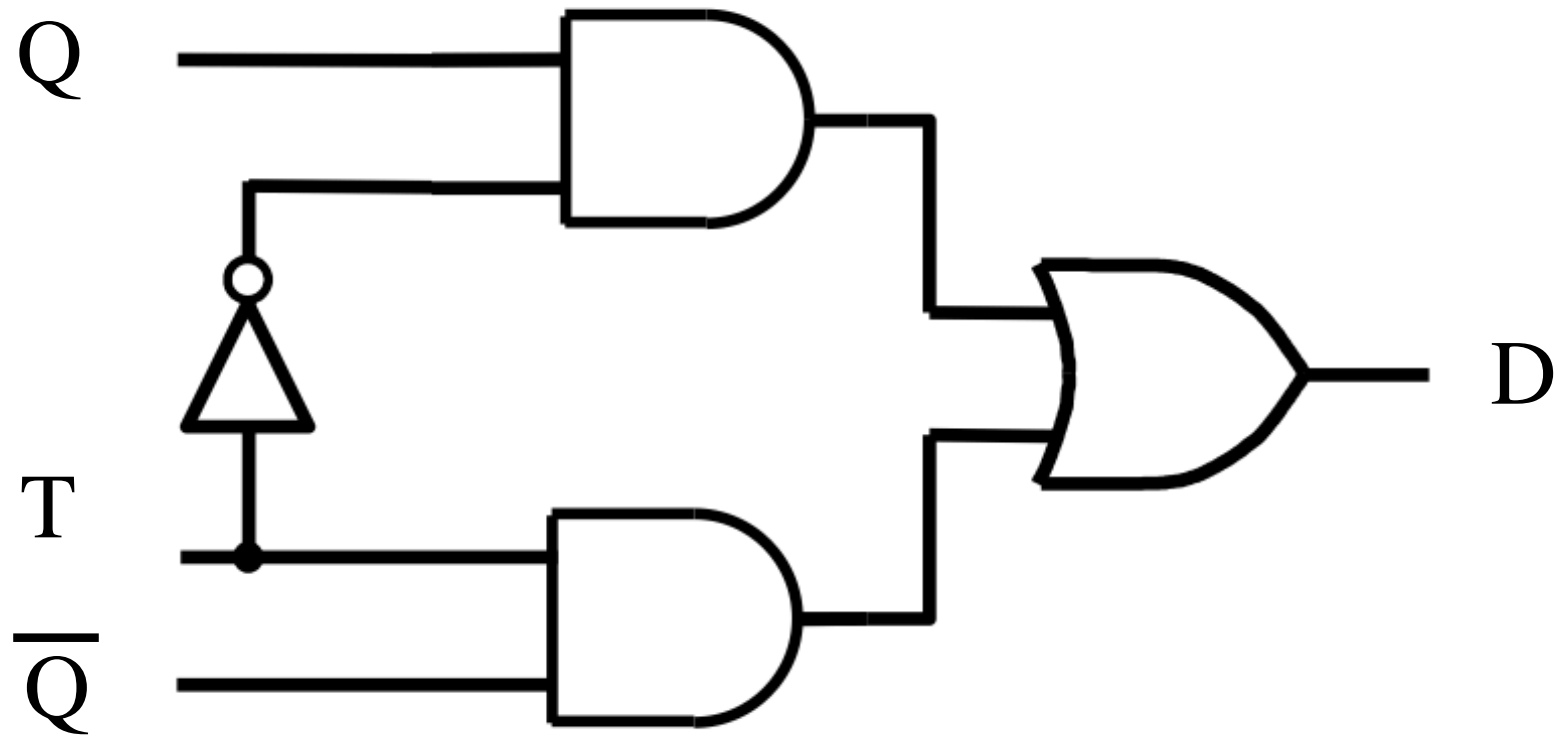

# What is this?

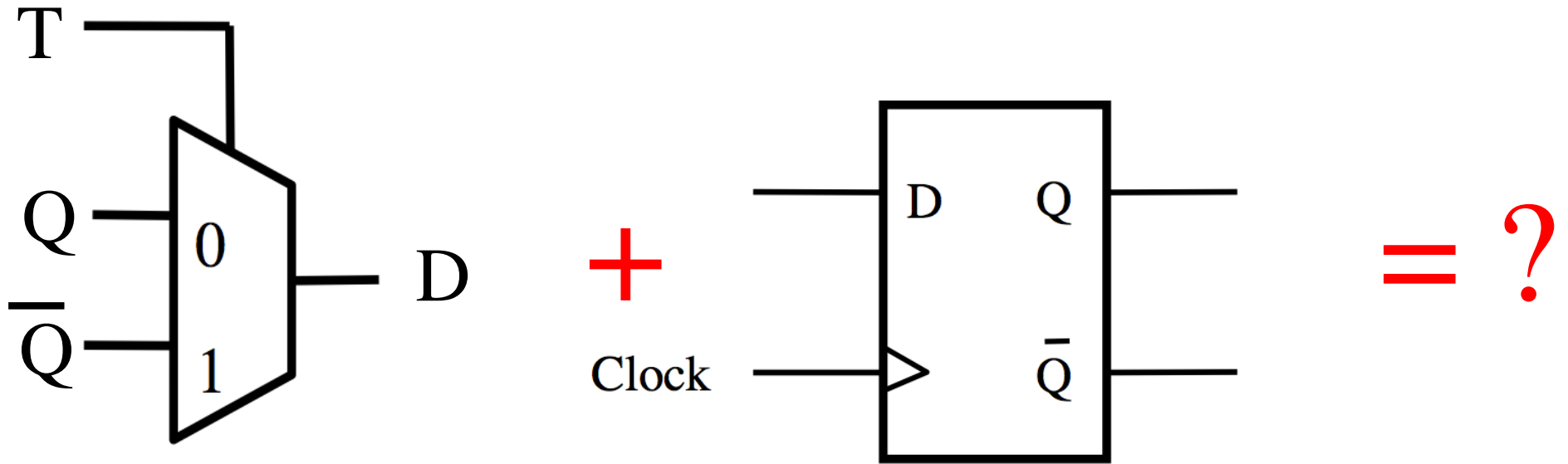

# T Flip-Flop

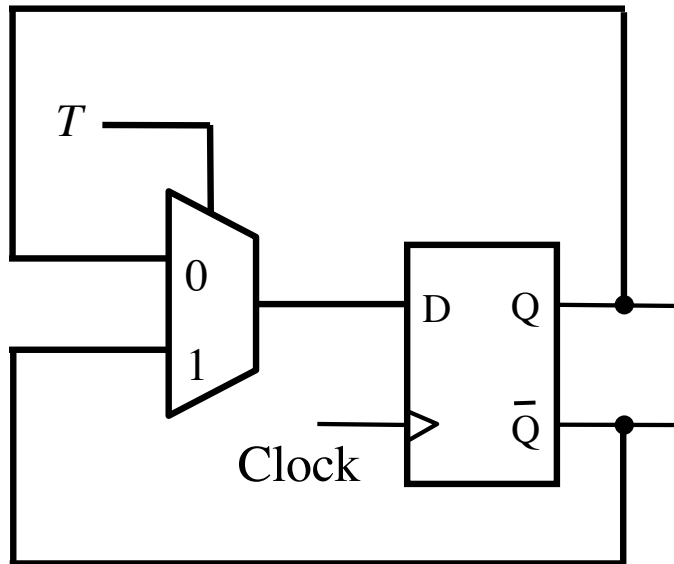

# T Flip-Flop

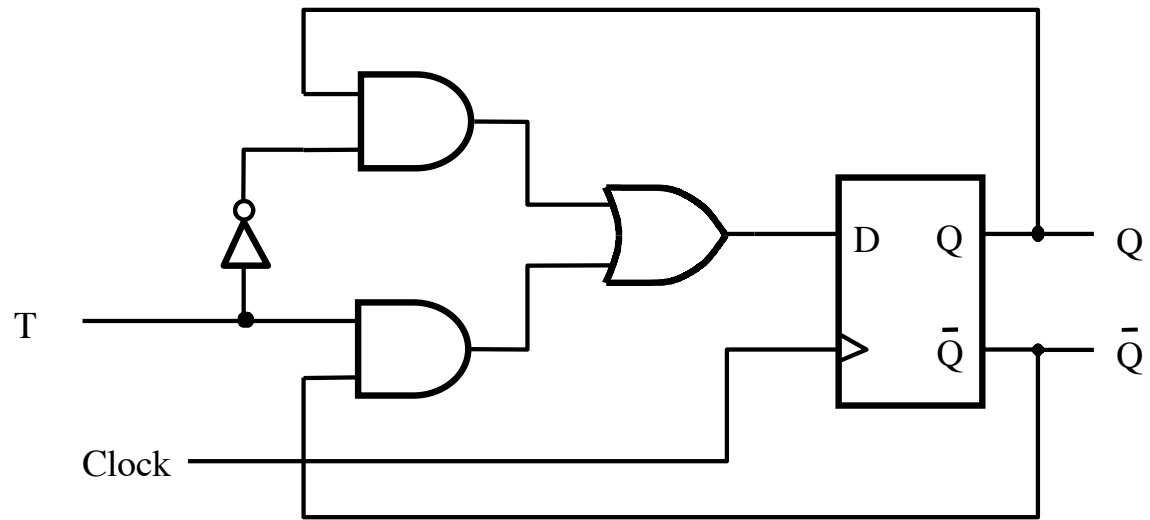

# T Flip-Flop

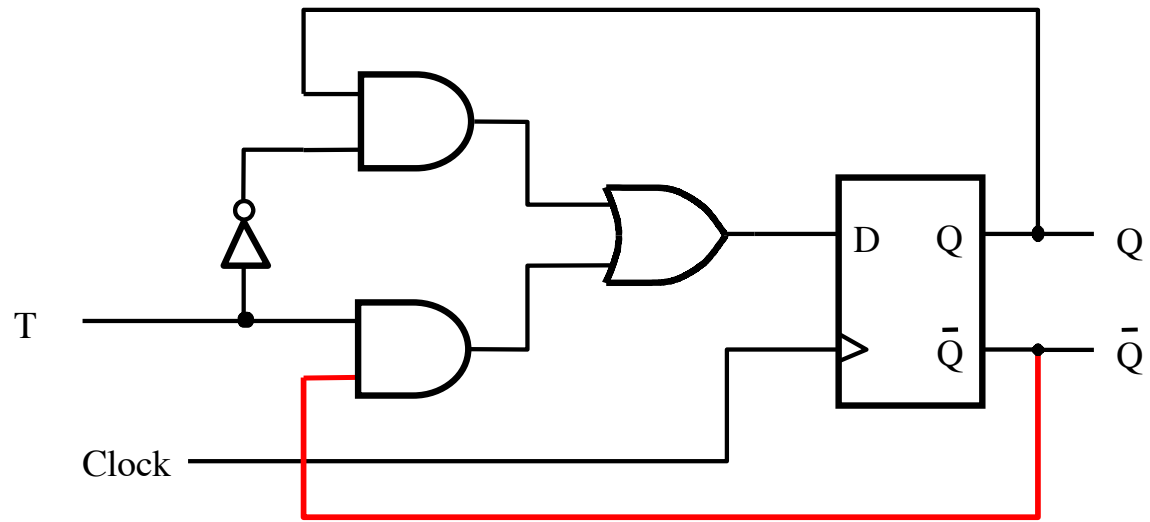



# T Flip-Flop

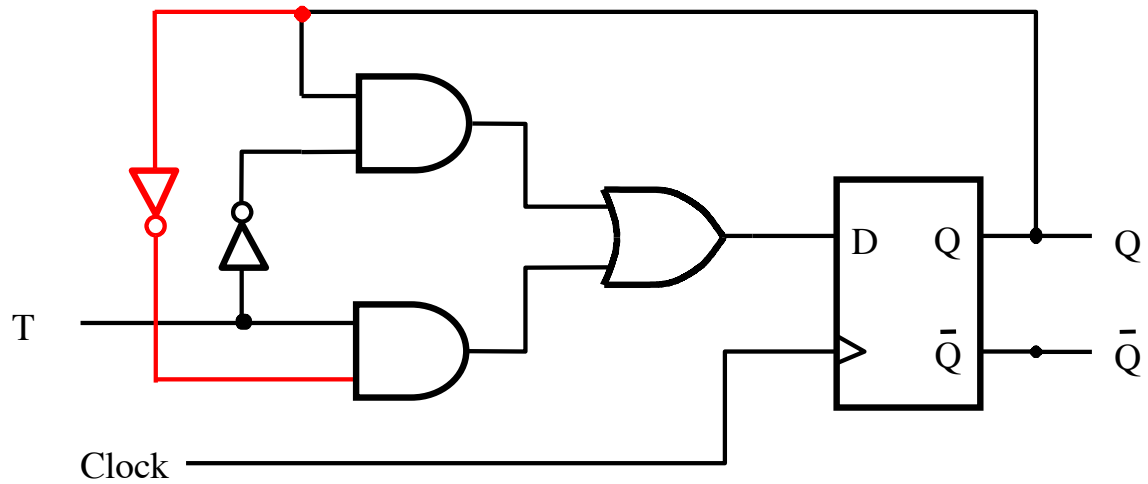

# These two circuits are equivalent

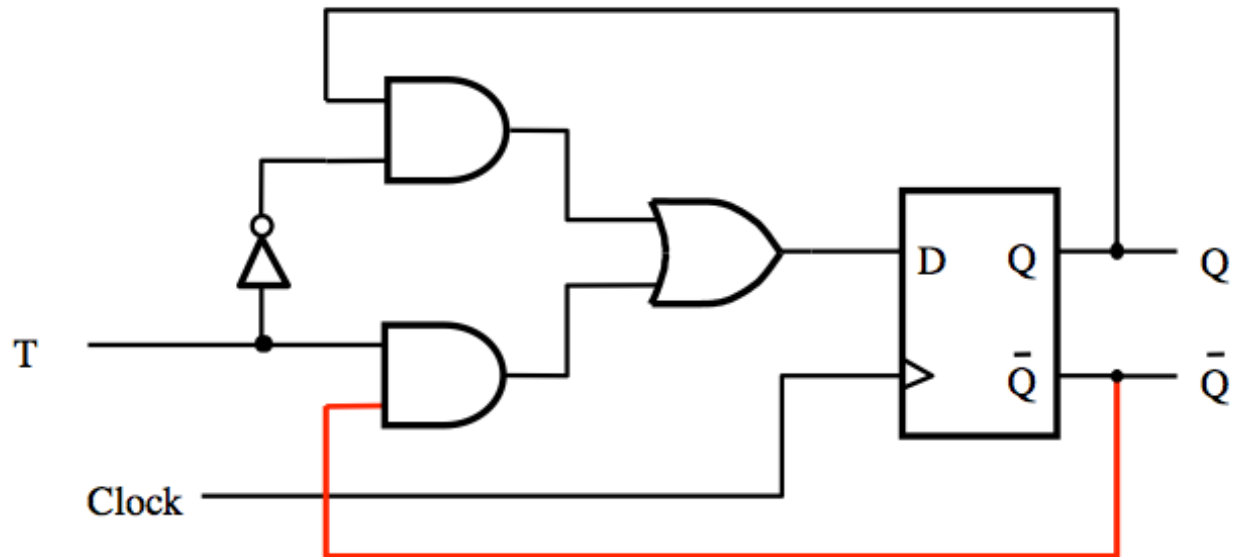
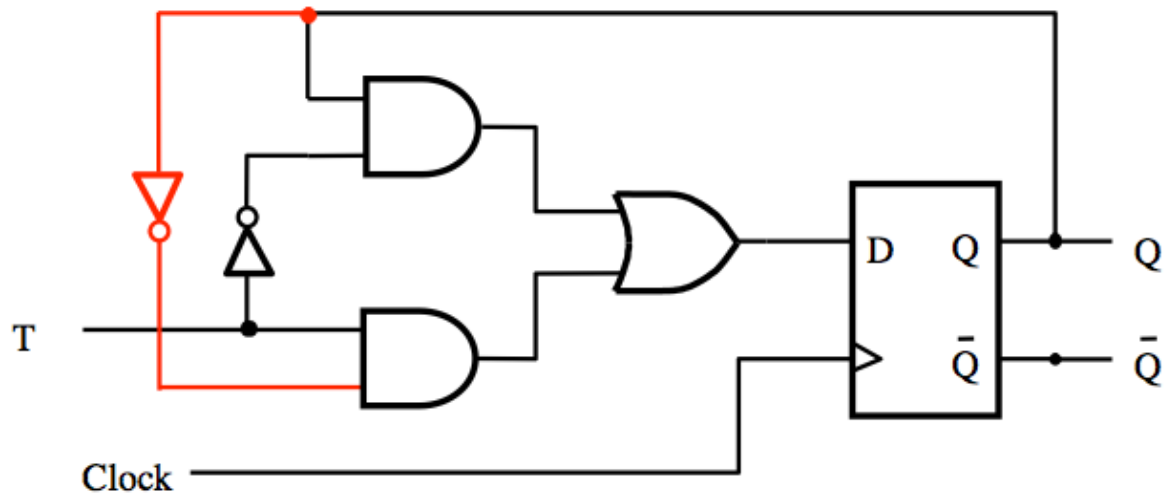

**What is this?**

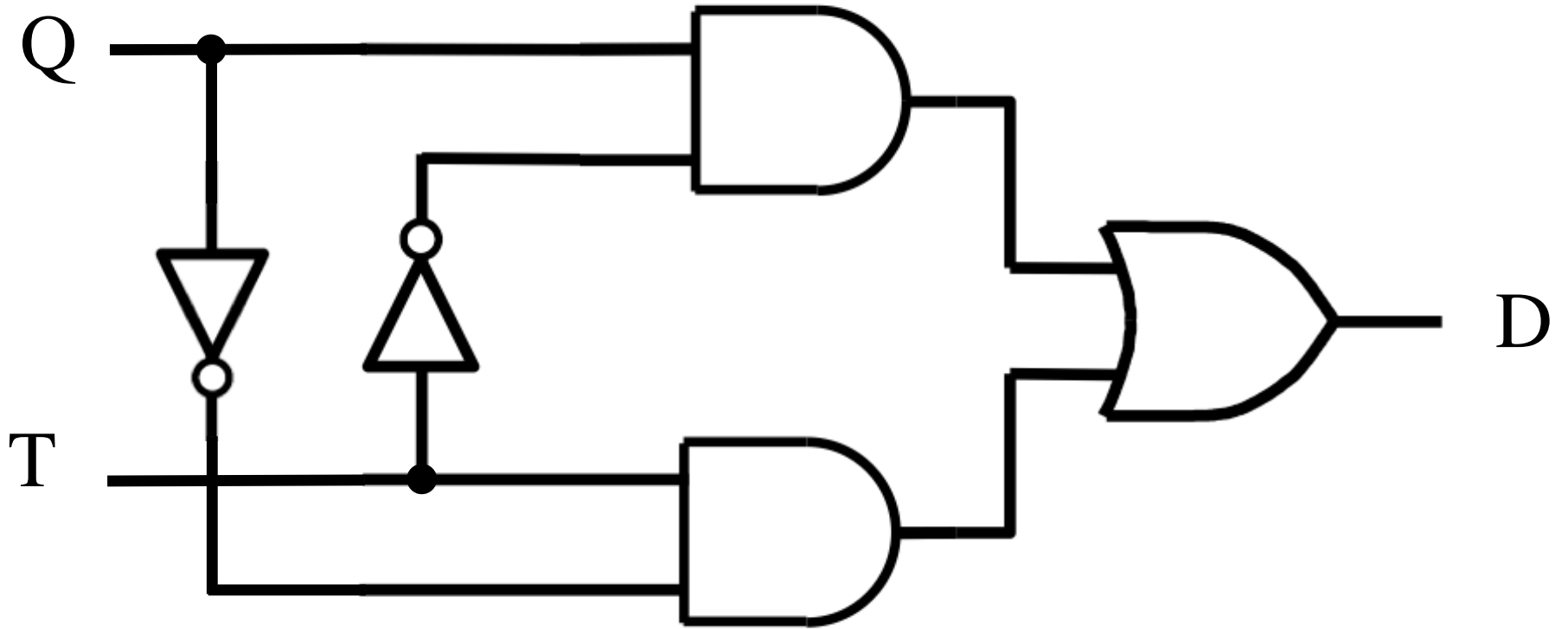

**What is this?**

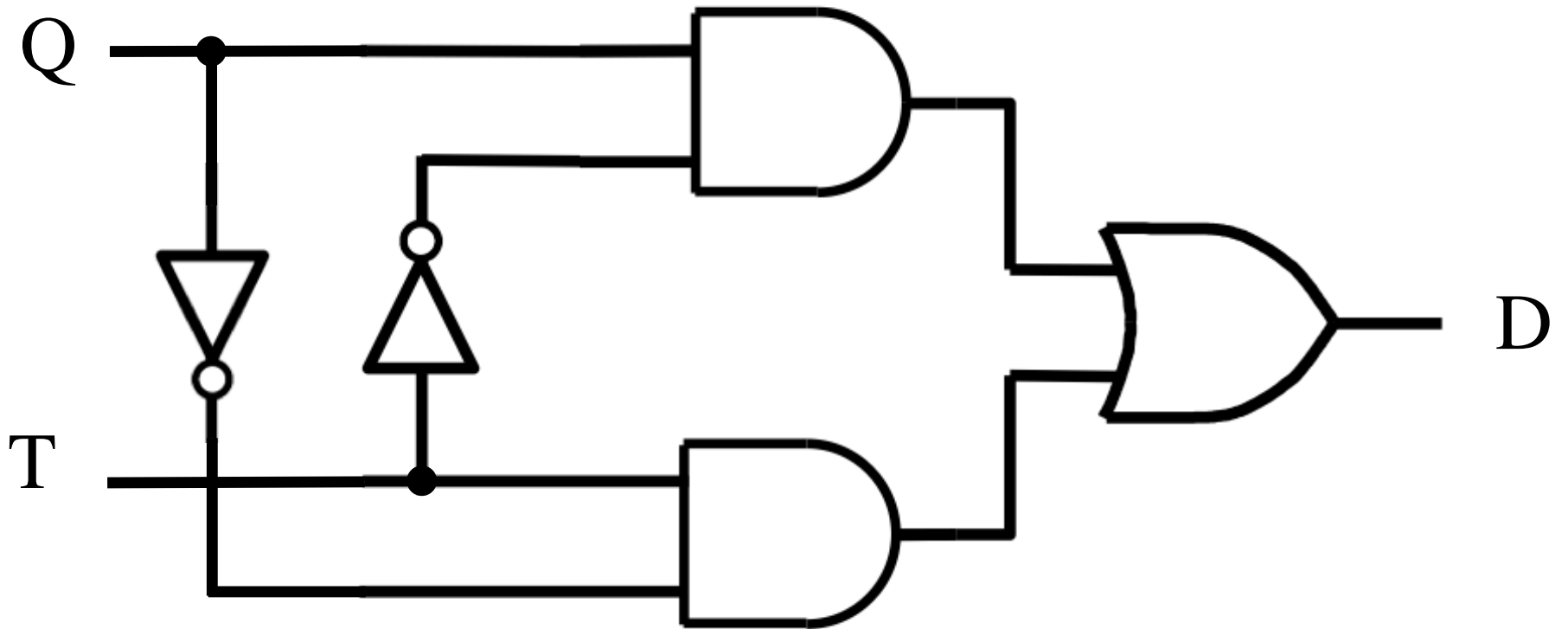

$$D = \overline{Q}T + Q\overline{T}$$

**What is this?**

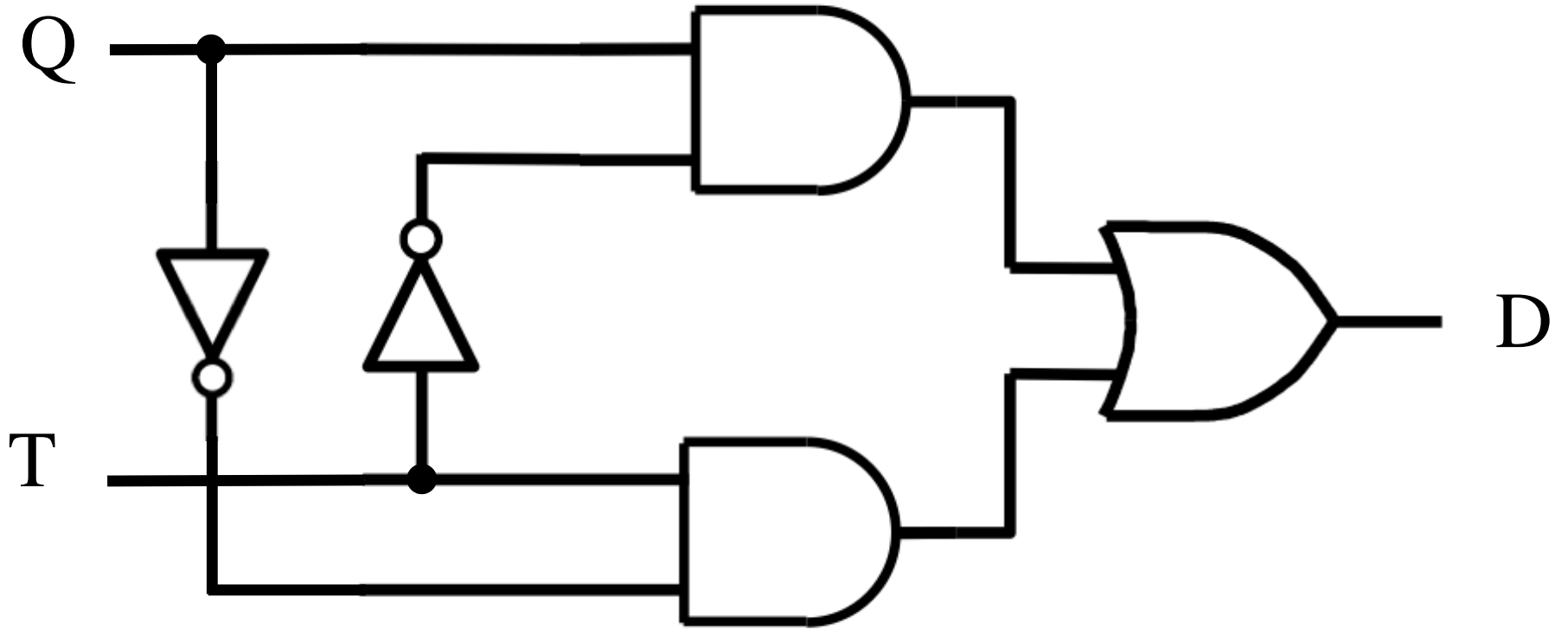

$$D = Q \oplus T$$

# What is this?

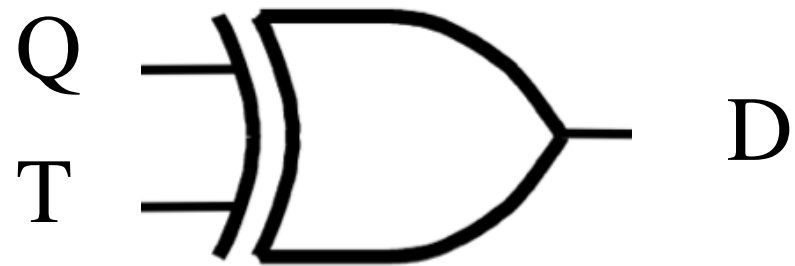

$$D = Q \oplus T$$

# What is this?

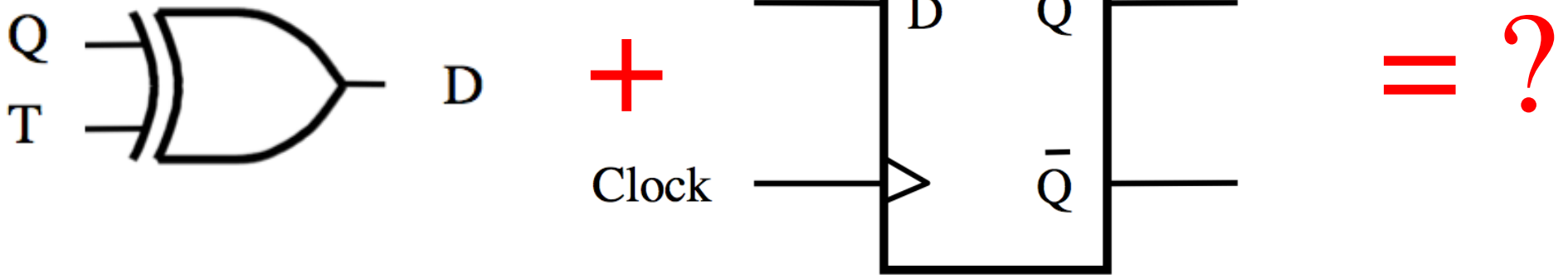

# T Flip-Flop

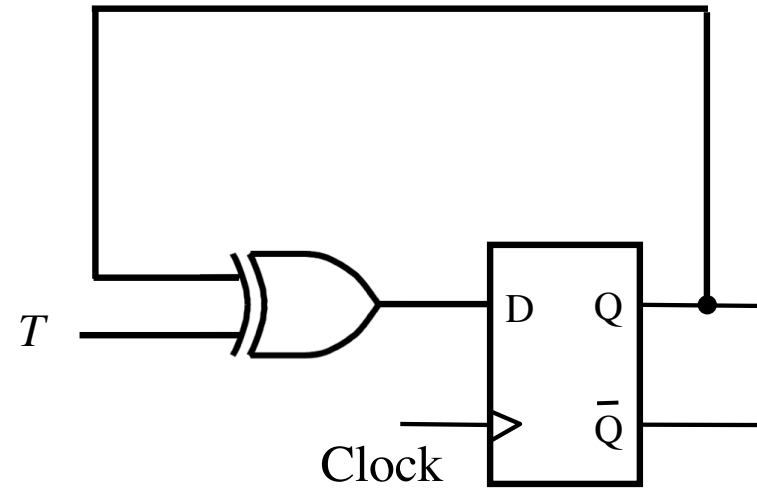



# **Synchronous Counter with D Flip-Flops**

# A three-bit up-counter with T flip-flops

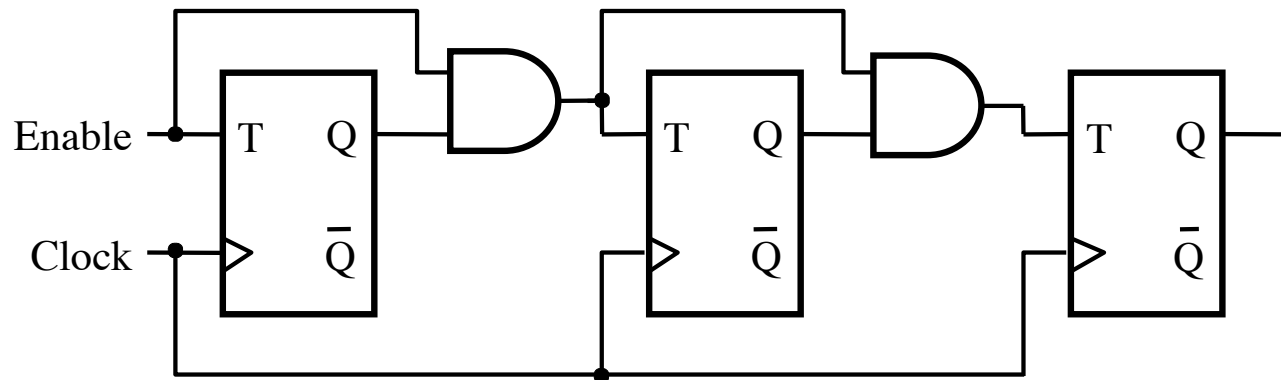

# A three-bit up-counter with D flip-flops

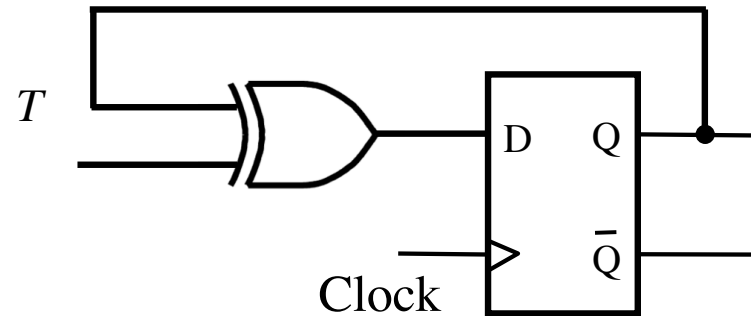
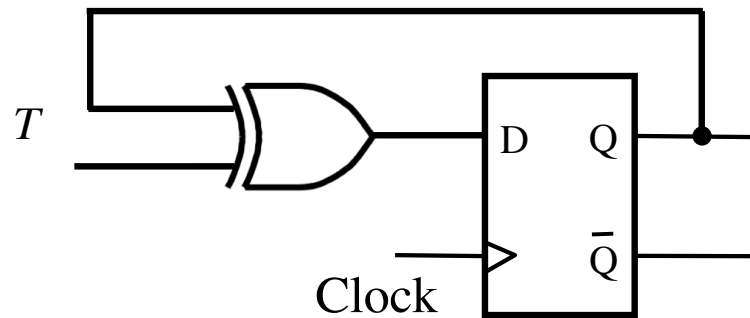
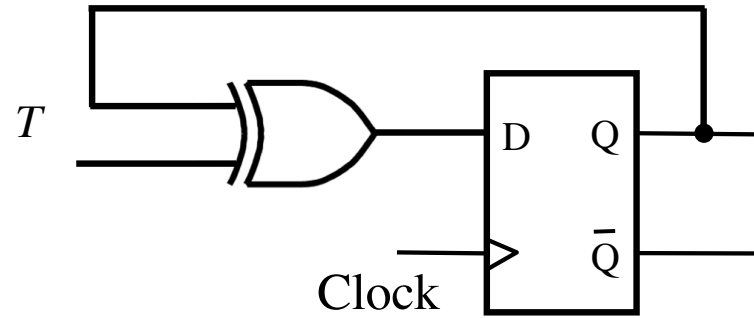

# A three-bit up-counter with D flip-flops

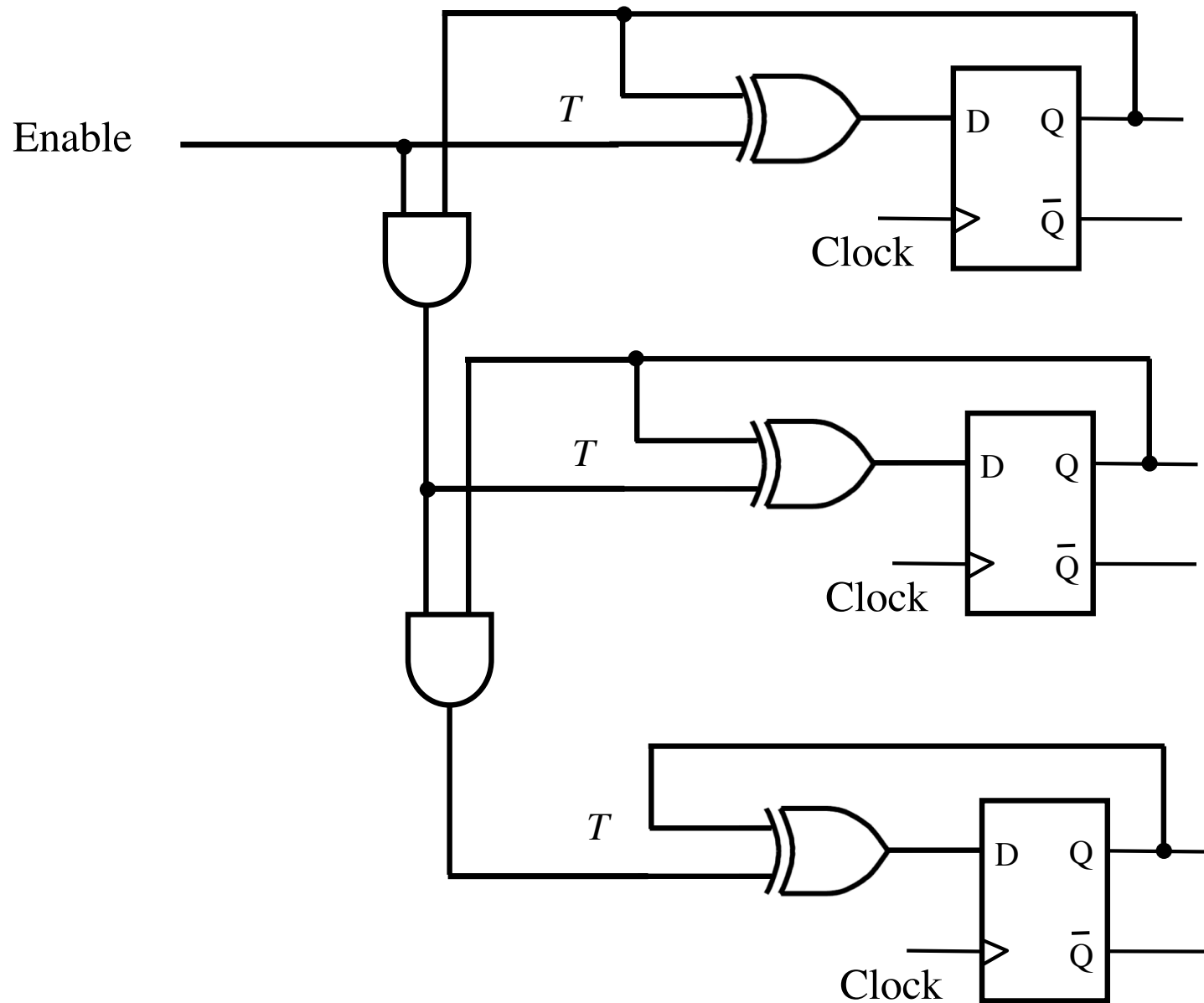

# A three-bit up-counter with D flip-flops

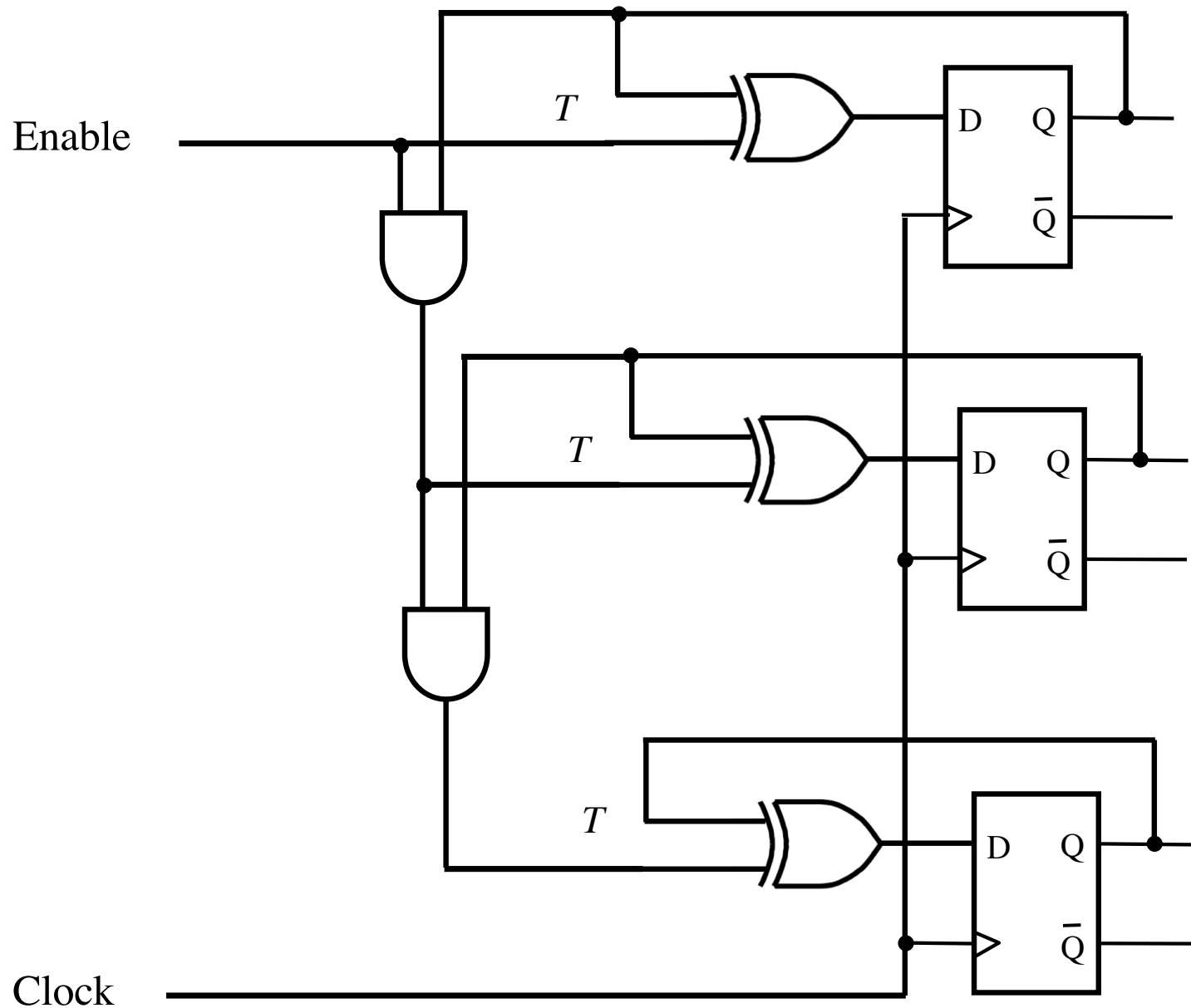

# A four-bit up-counter with T flip-flops

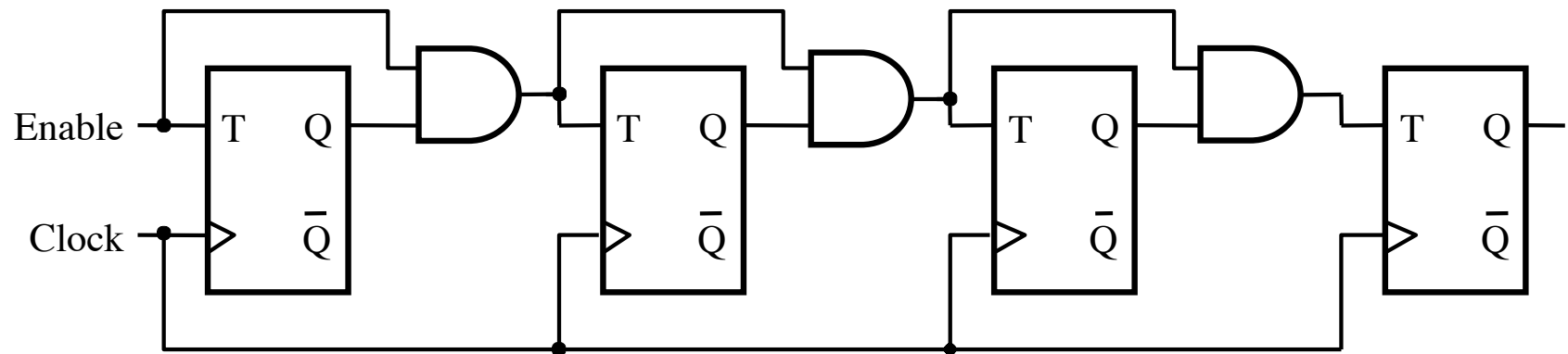

# A four-bit up-counter with D flip-flops

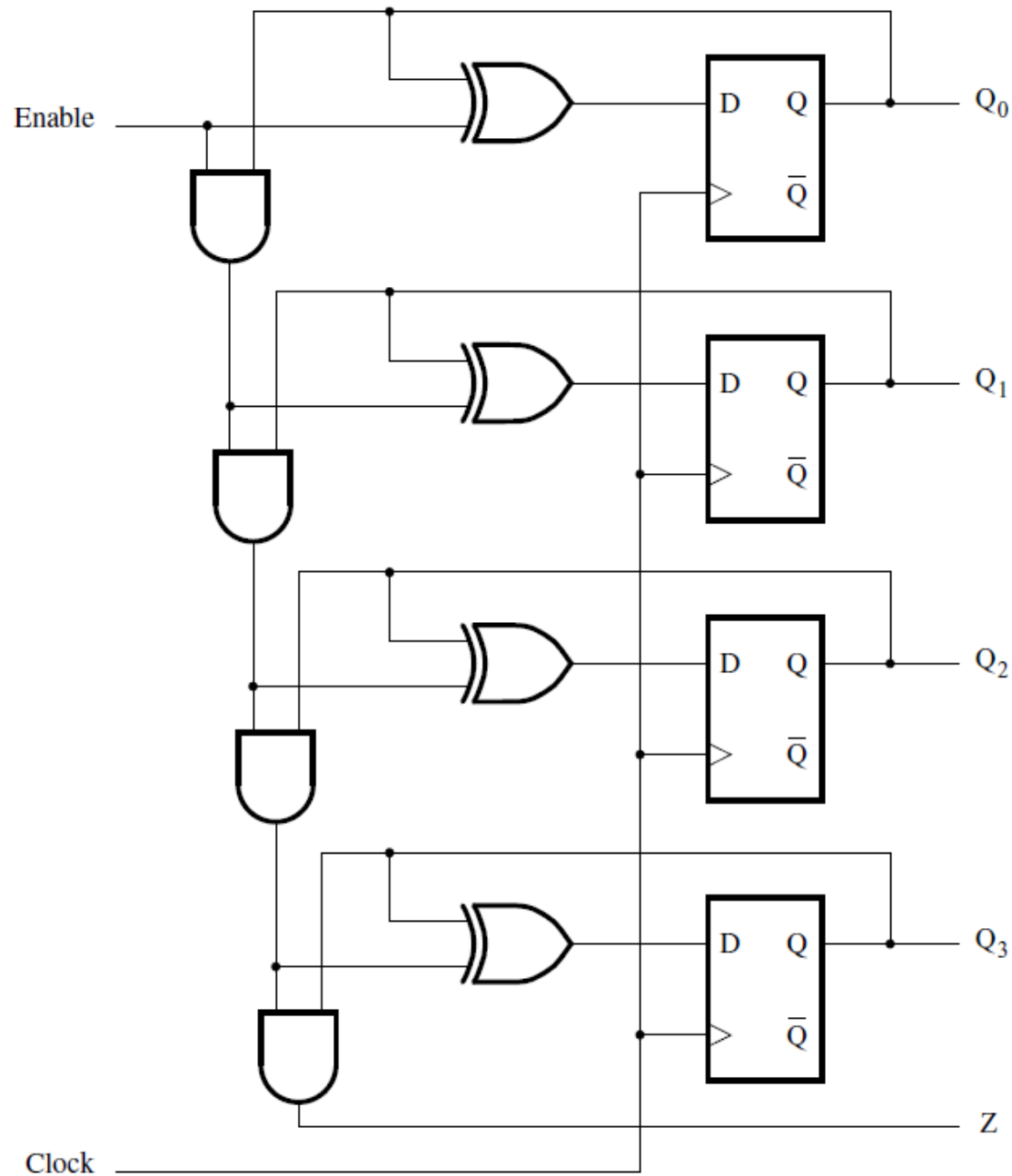

[ Figure 5.23 from the textbook ]

**End of Mini Review**



# Goal

- **Implement a modulo-8 counter using the sequential circuit approach**
- **In other words, the counting sequence must be 0, 1, 2, 3, 4, 5, 6, 7, 0, 1, 2, ...**
- **The count changes based on the input signal  $w$ :**
  - **If  $w=0$ , then the count remains the same**
  - **If  $w=1$ , then the count is advanced by one**

# State diagram for the counter

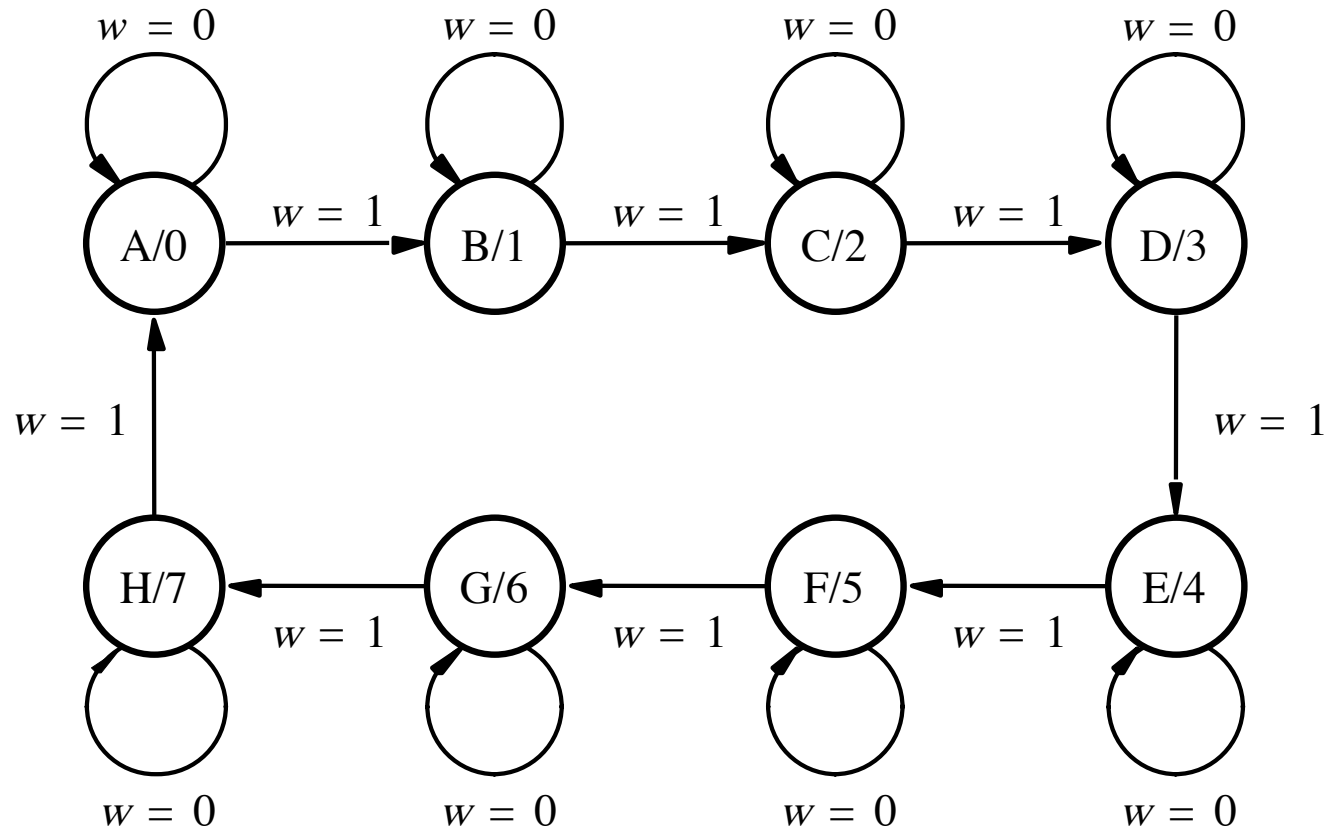

# State table for the counter

Present state	Next state		Output
	$w = 0$	$w = 1$	
A	A	B	0
B	B	C	1
C	C	D	2
D	D	E	3
E	E	F	4
F	F	G	5
G	G	H	6
H	H	A	7

# State-assigned table for the counter

	Present state $y_2y_1y_0$	Next state		Count $z_2z_1z_0$
		$w = 0$	$w = 1$	
		$Y_2Y_1Y_0$	$Y_2Y_1Y_0$	
A	000	000	001	000
B	001	001	010	001
C	010	010	011	010
D	011	011	100	011
E	100	100	101	100
F	101	101	110	101
G	110	110	111	110
H	111	111	000	111

# K-map for $Y_0$

	Present state $y_2y_1y_0$	Next state		Count $z_2z_1z_0$
		$w = 0$	$w = 1$	
		$Y_2Y_1Y_0$	$Y_2Y_1Y_0$	
A	000	000	001	000
B	001	001	010	001
C	010	010	011	010
D	011	011	100	011
E	100	100	101	100
F	101	101	110	101
G	110	110	111	110
H	111	111	000	111

		$y_1y_0$			
		00	01	11	10
$wy_2$	00				
	01				
	11				
	10				

# K-map for $Y_0$

	Present state $y_2y_1y_0$	Next state		Count $z_2z_1z_0$
		$w = 0$	$w = 1$	
		$Y_2Y_1Y_0$	$Y_2Y_1Y_0$	
A	000	0	1	000
B	001	1	0	001
C	010	0	1	010
D	011	1	0	011
E	100	0	1	100
F	101	1	0	101
G	110	0	1	110
H	111	1	0	111

	$y_1y_0$	00	01	11	10
$wy_2$	00				
	01				
	11				
	10				

# K-map for $Y_0$

	Present state $y_2y_1y_0$	Next state		Count $z_2z_1z_0$
		$w = 0$	$w = 1$	
		$Y_2Y_1Y_0$	$Y_2Y_1Y_0$	
A	000	0	1	000
B	001	1	0	001
C	010	0	1	010
D	011	1	0	011
E	100	0	1	100
F	101	1	0	101
G	110	0	1	110
H	111	1	0	111

$wy_2$ \ $y_1y_0$	00	01	11	10
00	0	1	1	0
01	0	1	1	0
11	1	0	0	1
10	1	0	0	1

# K-map for $Y_0$

	Present state $y_2y_1y_0$	Next state		Count $z_2z_1z_0$
		$w = 0$	$w = 1$	
		$Y_2Y_1Y_0$	$Y_2Y_1Y_0$	
A	000	0	1	000
B	001	1	0	001
C	010	0	1	010
D	011	1	0	011
E	100	0	1	100
F	101	1	0	101
G	110	0	1	110
H	111	1	0	111

		$y_1y_0$			
		00	01	11	10
$wy_2$	00	0	1	1	0
	01	0	1	1	0
	11	1	0	0	1
	10	1	0	0	1

$$Y_0 = \bar{w}y_0 + w\bar{y}_0$$



# K-map for $Y_1$

	Present state $y_2y_1y_0$	Next state		Count $z_2z_1z_0$
		$w = 0$	$w = 1$	
		$Y_2Y_1Y_0$	$Y_2Y_1Y_0$	
A	000	000	001	000
B	001	001	010	001
C	010	010	011	010
D	011	011	100	011
E	100	100	101	100
F	101	101	110	101
G	110	110	111	110
H	111	111	000	111

		$y_1y_0$			
		00	01	11	10
$wy_2$	00				
	01				
	11				
	10				

# K-map for $Y_1$

	Present state $y_2y_1y_0$	Next state		Count $z_2z_1z_0$
		$w = 0$	$w = 1$	
		$Y_2Y_1Y_0$	$Y_2Y_1Y_0$	
A	000	0	0	000
B	001	0	1	001
C	010	1	1	010
D	011	1	0	011
E	100	0	0	100
F	101	0	1	101
G	110	1	1	110
H	111	1	0	111

		$y_1y_0$			
	$wy_2$	00	01	11	10
00					
01					
11					
10					

# K-map for $Y_1$

	Present state $y_2y_1y_0$	Next state		Count $z_2z_1z_0$
		$w = 0$	$w = 1$	
		$Y_2Y_1Y_0$	$Y_2Y_1Y_0$	
A	000	0	0	000
B	001	0	1	001
C	010	1	1	010
D	011	1	0	011
E	100	0	0	100
F	101	0	1	101
G	110	1	1	110
H	111	1	0	111

		$y_1y_0$			
		00	01	11	10
$wy_2$	00	0	0	1	1
	01	0	0	1	1
	11	0	1	0	1
	10	0	1	0	1

# K-map for $Y_1$

	Present state $y_2y_1y_0$	Next state		Count $z_2z_1z_0$
		$w = 0$	$w = 1$	
		$Y_2Y_1Y_0$	$Y_2Y_1Y_0$	
A	000	0	0	000
B	001	0	1	001
C	010	1	1	010
D	011	1	0	011
E	100	0	0	100
F	101	0	1	101
G	110	1	1	110
H	111	1	0	111

		$y_1y_0$			
		00	01	11	10
$wy_2$	00	0	0	1	1
	01	0	0	1	1
	11	0	1	0	1
	10	0	1	0	1

$$Y_1 = \bar{w}y_1 + y_1\bar{y}_0 + wy_0\bar{y}_1$$

# K-map for $Y_2$

	Present state $y_2y_1y_0$	Next state		Count $z_2z_1z_0$
		$w = 0$	$w = 1$	
		$Y_2Y_1Y_0$	$Y_2Y_1Y_0$	
A	000	000	001	000
B	001	001	010	001
C	010	010	011	010
D	011	011	100	011
E	100	100	101	100
F	101	101	110	101
G	110	110	111	110
H	111	111	000	111

		$y_1y_0$			
	$wy_2$	00	01	11	10
00					
01					
11					
10					

# K-map for $Y_2$

	Present state $y_2y_1y_0$	Next state		Count $z_2z_1z_0$
		$w = 0$	$w = 1$	
		$Y_2Y_1Y_0$	$Y_2Y_1Y_0$	
A	000	0	0	000
B	001	0	0	001
C	010	0	0	010
D	011	0	1	011
E	100	1	1	100
F	101	1	1	101
G	110	1	1	110
H	111	1	0	111

	$y_1y_0$	00	01	11	10
$wy_2$	00				
	01				
	11				
	10				

# K-map for $Y_2$

	Present state $y_2y_1y_0$	Next state		Count $z_2z_1z_0$
		$w = 0$	$w = 1$	
		$Y_2Y_1Y_0$	$Y_2Y_1Y_0$	
A	000	0	0	000
B	001	0	0	001
C	010	0	0	010
D	011	0	1	011
E	100	1	1	100
F	101	1	1	101
G	110	1	1	110
H	111	1	0	111

		$y_1y_0$			
		00	01	11	10
$wy_2$	00	0	0	0	0
	01	1	1	1	1
	11	1	1	0	1
	10	0	0	1	0

# K-map for $Y_2$

	Present state $y_2y_1y_0$	Next state		Count $z_2z_1z_0$
		$w = 0$	$w = 1$	
		$Y_2Y_1Y_0$	$Y_2Y_1Y_0$	
A	000	0	0	000
B	001	0	0	001
C	010	0	0	010
D	011	0	1	011
E	100	1	1	100
F	101	1	1	101
G	110	1	1	110
H	111	1	0	111

$wy_2$ \ $y_1y_0$	00	01	11	10
00	0	0	0	0
01	1	1	1	1
11	1	1	0	1
10	0	0	1	0

$$Y_2 = \bar{w}y_2 + \bar{y}_0y_2 + \bar{y}_1y_2 + wy_0y_1\bar{y}_2$$



# Karnaugh maps for D flip-flops for the counter

		$y_1y_0$			
		00	01	11	10
$wy_2$	00	0	1	1	0
	01	0	1	1	0
	11	1	0	0	1
	10	1	0	0	1

$$Y_0 = \bar{w}y_0 + wy_0$$

		$y_1y_0$			
		00	01	11	10
$wy_2$	00	0	0	1	1
	01	0	0	1	1
	11	0	1	0	1
	10	0	1	0	1

$$Y_1 = \bar{w}y_1 + y_1\bar{y}_0 + wy_0\bar{y}_1$$

		$y_1y_0$			
		00	01	11	10
$wy_2$	00	0	0	0	0
	01	1	1	1	1
	11	1	1	0	1
	10	0	0	1	0

$$Y_2 = \bar{w}y_2 + \bar{y}_0y_2 + \bar{y}_1y_2 + wy_0y_1\bar{y}_2$$

Circuit diagram  
for the counter  
implemented  
with D flip-flops

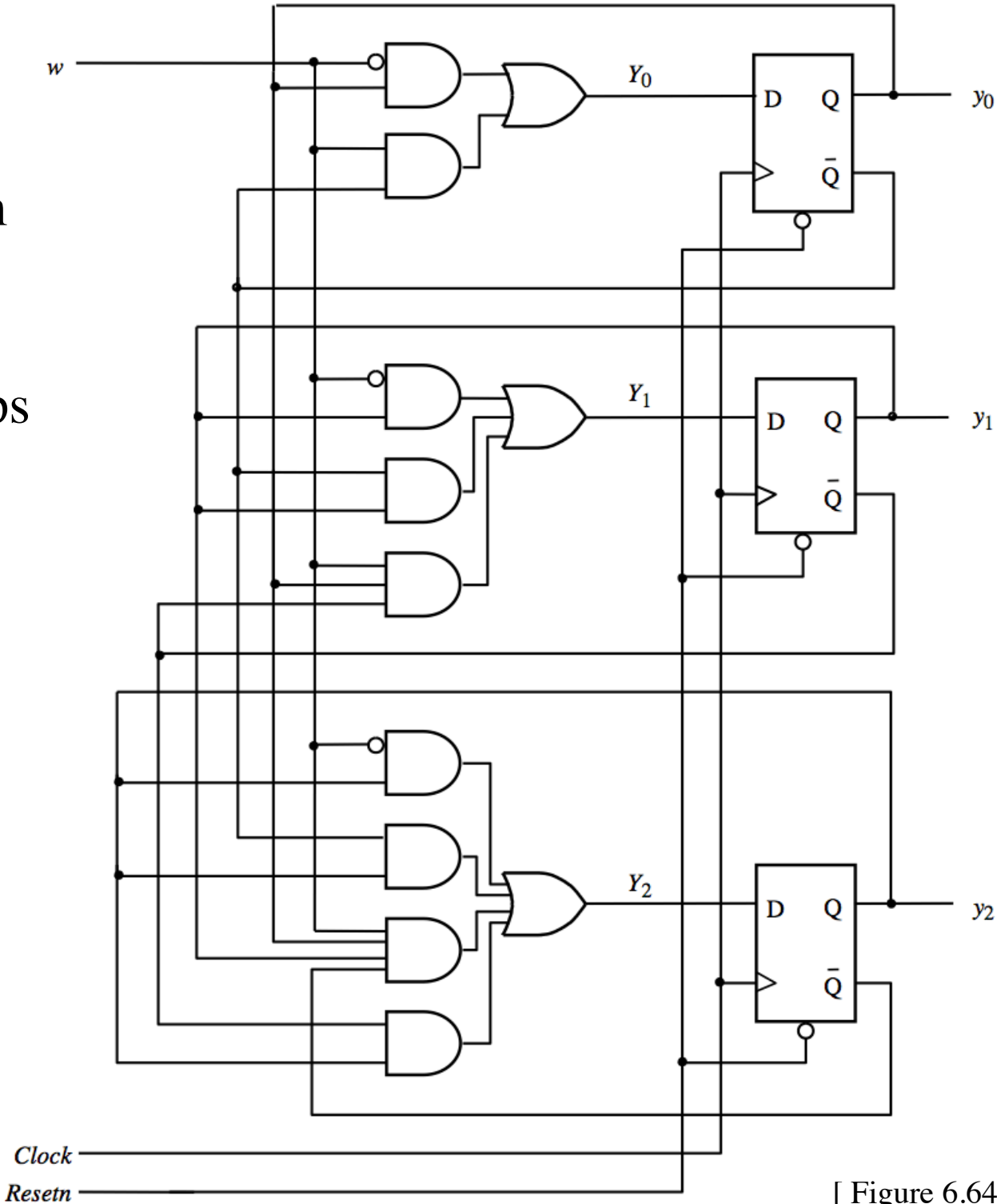

[ Figure 6.64 from the textbook ]

Circuit diagram  
for the counter  
implemented  
with D flip-flops

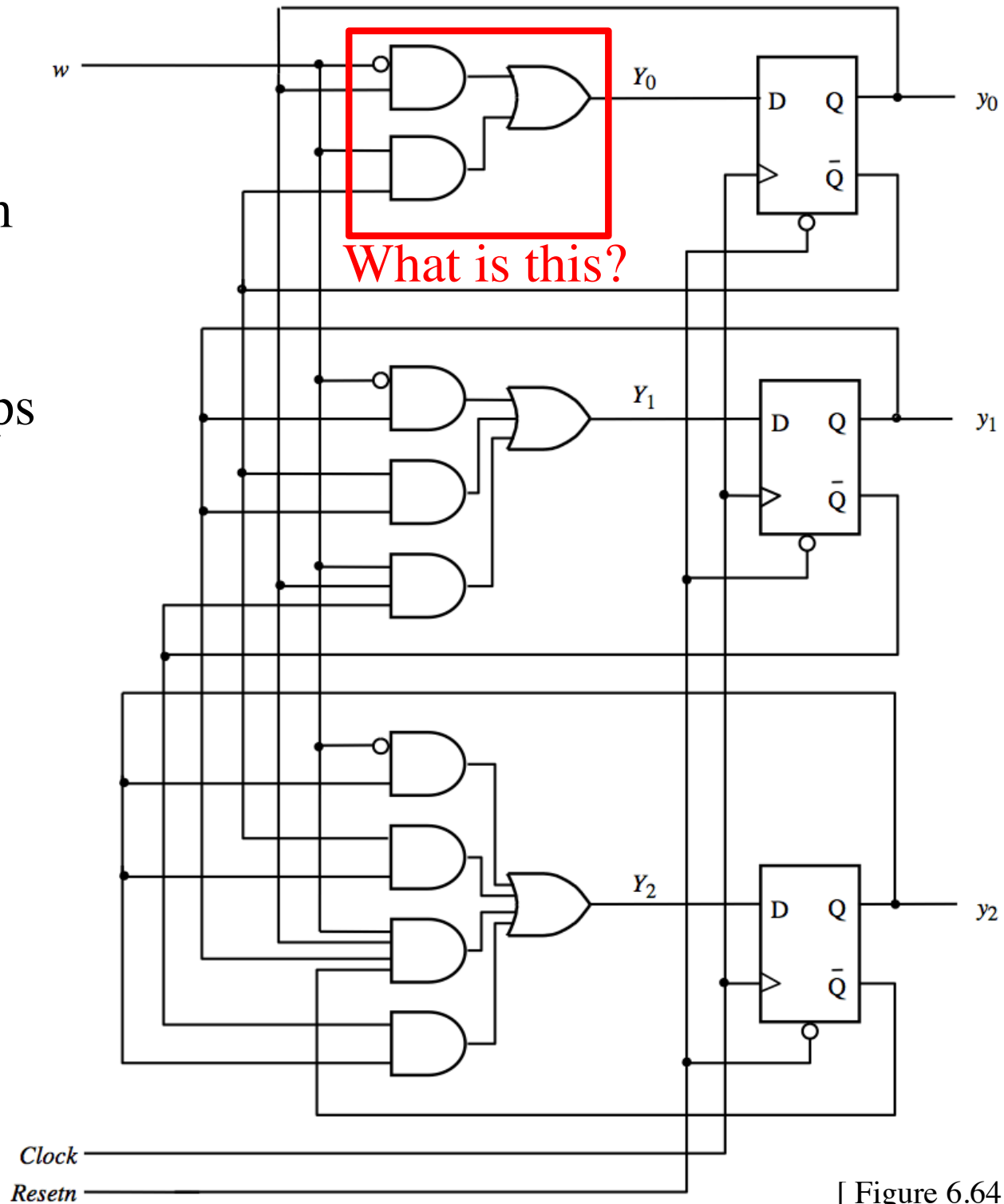

[ Figure 6.64 from the textbook ]

Circuit diagram  
for the counter  
implemented  
with D flip-flops

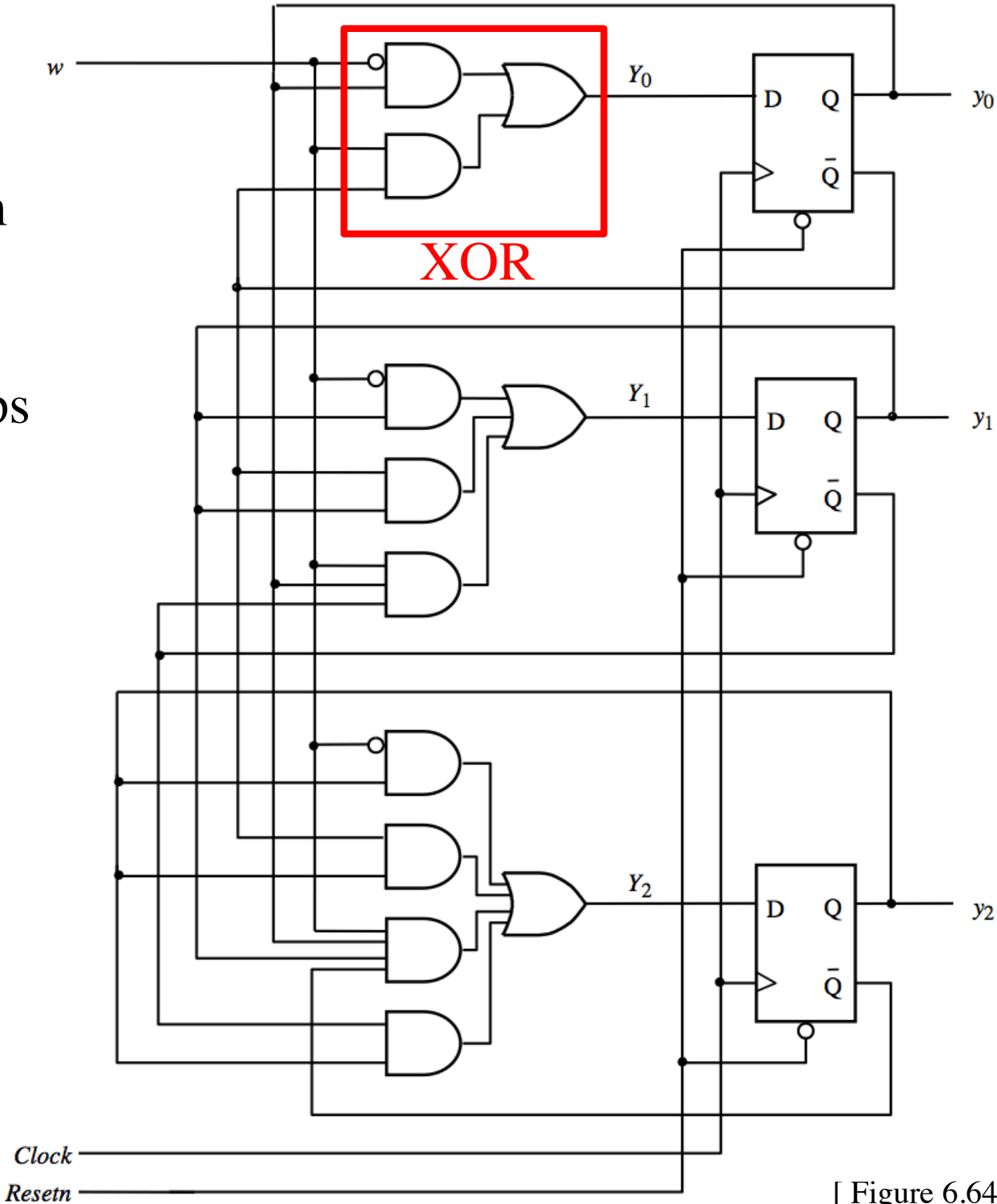

[ Figure 6.64 from the textbook ]

# We can simplify all three expressions

$$Y_0 = \bar{w}y_0 + wy_0\bar{y}_0$$

$$Y_1 = \bar{w}y_1 + y_1\bar{y}_0 + wy_0\bar{y}_1$$

$$Y_2 = \bar{w}y_2 + \bar{y}_0y_2 + \bar{y}_1y_2 + wy_0y_1\bar{y}_2$$

# We can simplify all three expressions

$$Y_0 = \bar{w}y_0 + w\bar{y}_0$$

$$\begin{aligned} D_0 &= \bar{w}y_0 + w\bar{y}_0 \\ &= w \oplus y_0 \end{aligned}$$

$$Y_1 = \bar{w}y_1 + y_1\bar{y}_0 + wy_0\bar{y}_1$$

$$\begin{aligned} D_1 &= \bar{w}y_1 + y_1\bar{y}_0 + wy_0\bar{y}_1 \\ &= (\bar{w} + \bar{y}_0)y_1 + wy_0\bar{y}_1 \\ &= \bar{w}\bar{y}_0y_1 + wy_0\bar{y}_1 \\ &= wy_0 \oplus y_1 \end{aligned}$$

$$Y_2 = \bar{w}y_2 + \bar{y}_0y_2 + \bar{y}_1y_2 + wy_0y_1\bar{y}_2$$

$$\begin{aligned} D_2 &= \bar{w}y_2 + \bar{y}_0y_2 + \bar{y}_1y_2 + wy_0y_1\bar{y}_2 \\ &= (\bar{w} + \bar{y}_0 + \bar{y}_1)y_2 + wy_0y_1\bar{y}_2 \\ &= \bar{w}\bar{y}_0\bar{y}_1y_2 + wy_0y_1\bar{y}_2 \\ &= wy_0y_1 \oplus y_2 \end{aligned}$$

# A three-bit counter with D flip-flops

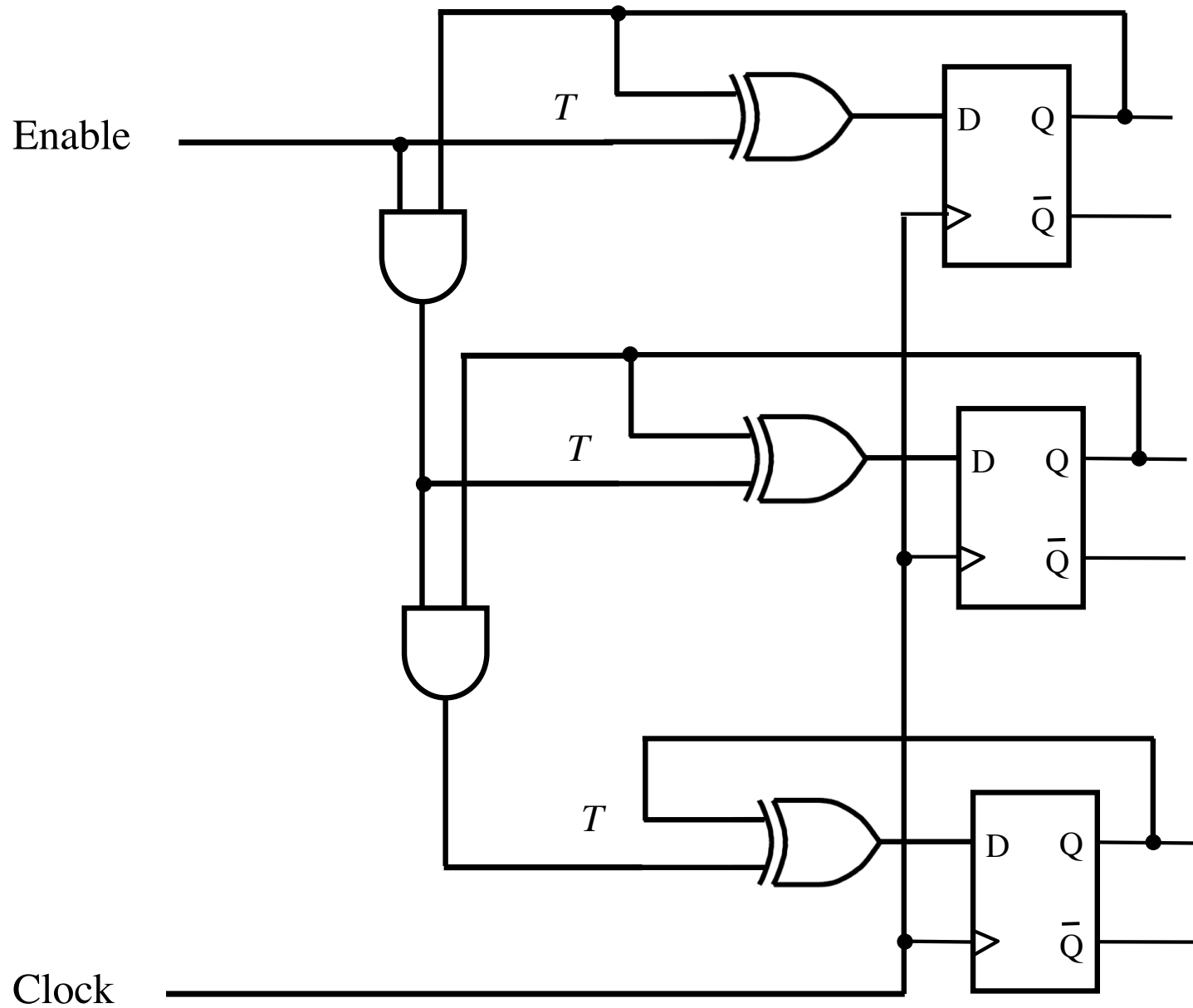

# A four-bit counter with D flip-flops

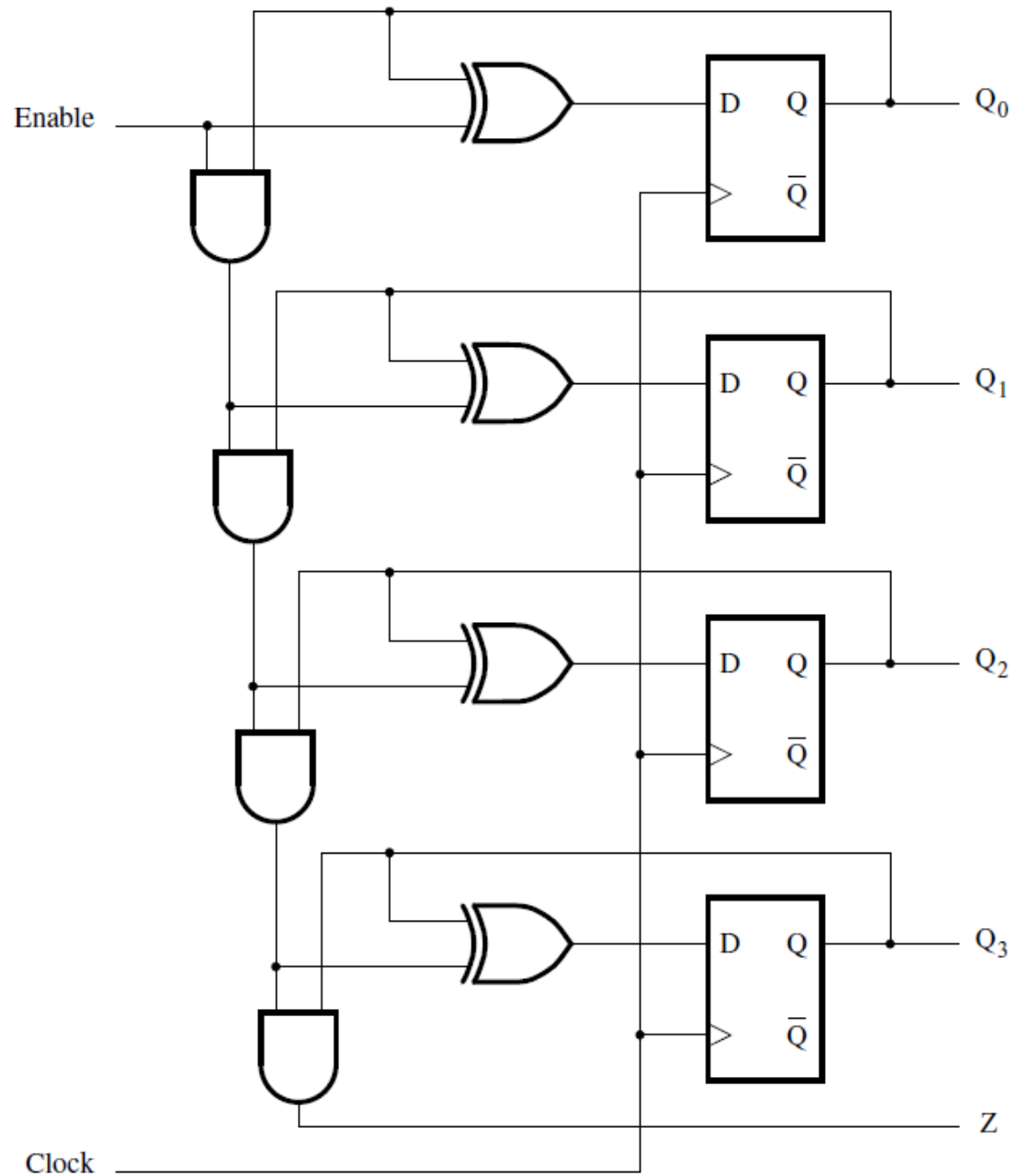

[ Figure 5.23 from the textbook ]



# Summary

- **The up-counters that we studied in Chapter 5 can now be derived using the sequential circuit approach**
- **We get the same circuit diagrams as before**

**Example 2:  
Implement a modulo-8 counter  
using JK Flip-Flops**

# JK Flip-Flop

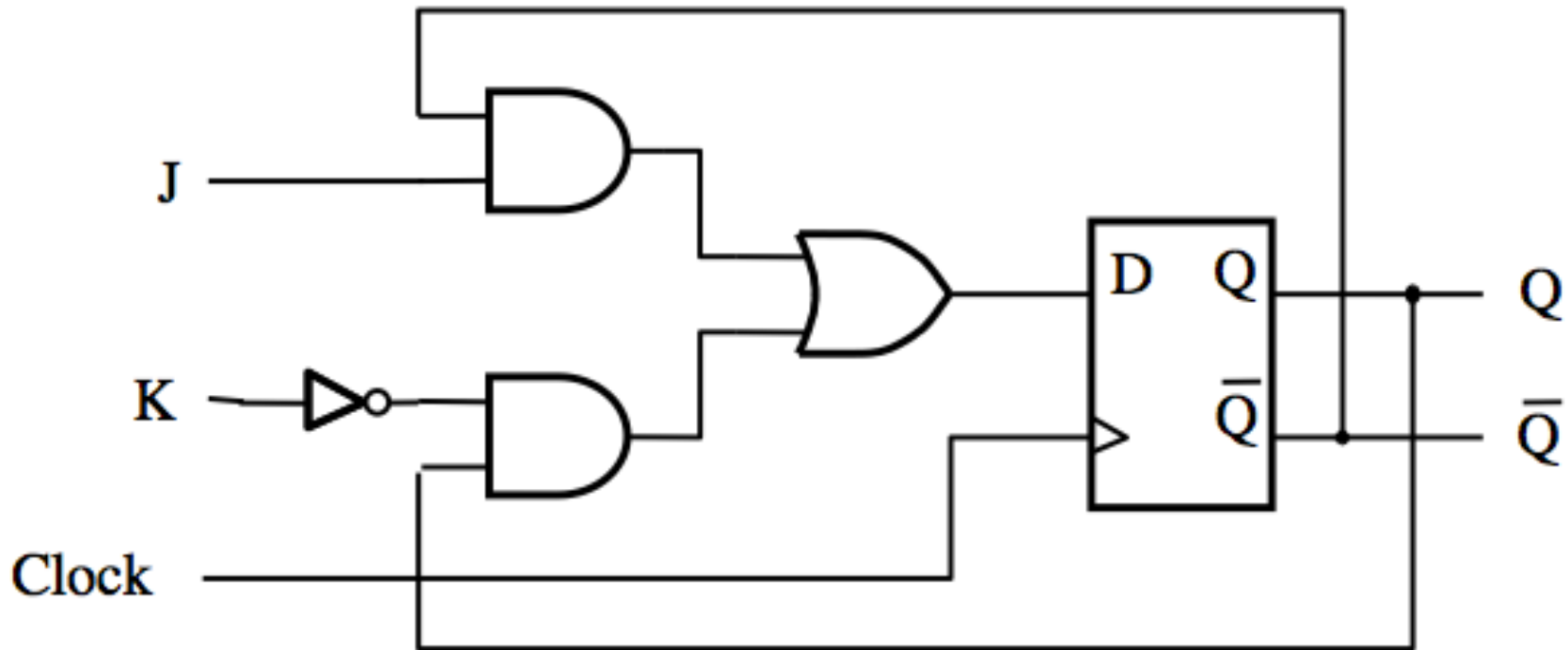

$$D = \overline{J}Q + \overline{K}Q$$

# JK Flip-Flop

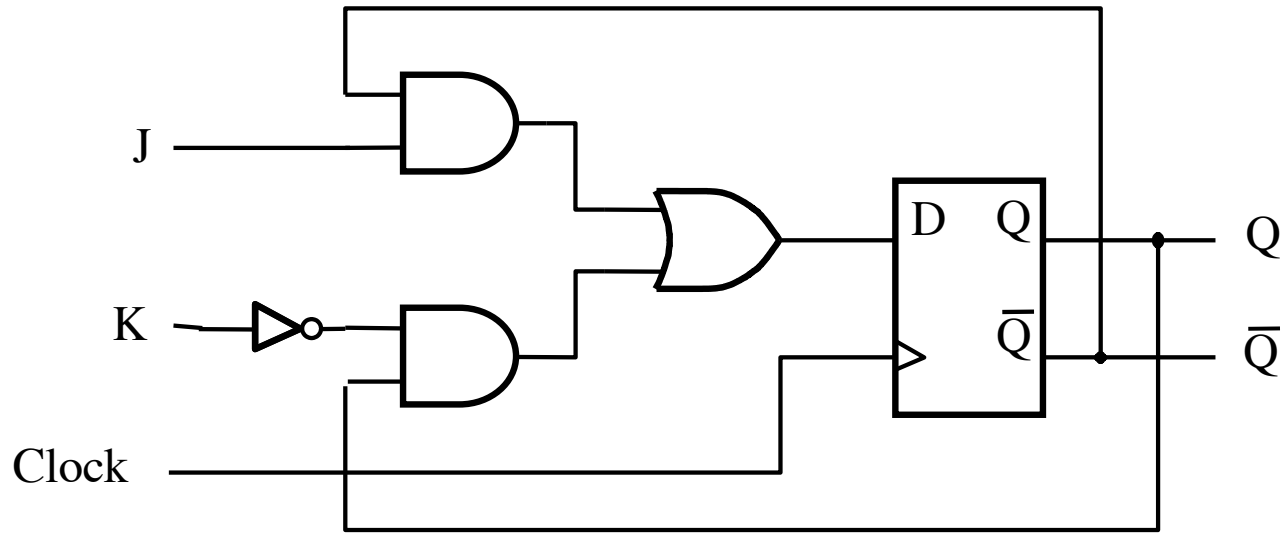

(a) Circuit

J	K	$Q(t+1)$
0	0	$Q(t)$
0	1	0
1	0	1
1	1	$\bar{Q}(t)$

(b) Truth table

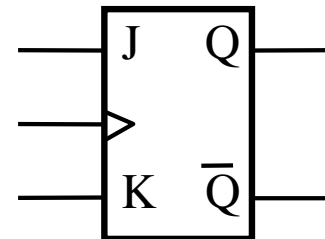

(c) Graphical symbol

# **JK Flip-Flop (How it Works)**

**A versatile circuit that can be used both as a SR flip-flop and as a T flip flop**

**If  $J=0$  and  $K=0$  it stays in the same state**

**Just like SR It can be set and reset**

**$J=S$  and  $K=R$**

**If  $J=K$  then it behaves as a T flip-flop**

# Transition Rules in terms of J and K

Current State  
of the Flip-flop:  $Q(t)$

Next State  
of the Flip-flop:  $Q(t+1)$

J	K	$Q(t+1)$
0	0	$Q(t)$
0	1	0
1	0	1
1	1	$\bar{Q}(t)$

- From 0 to 0       $J=0$  and  $K=d$
- From 0 to 1       $J=1$  and  $K=d$
- From 1 to 0       $J=d$  and  $K=1$
- From 1 to 1       $J=d$  and  $K=0$

# Transition Rules in terms of J and K

Current State of the Flip-flop:  $Q(t)$       Next State of the Flip-flop:  $Q(t+1)$

- From 0 to 0       $J=0$  and  $K=d$
- From 0 to 1       $J=1$  and  $K=d$
- From 1 to 0       $J=d$  and  $K=1$
- From 1 to 1       $J=d$  and  $K=0$

J	K	$Q(t+1)$
0	0	$Q(t)$
0	1	0
1	0	1
1	1	$\bar{Q}(t)$

$Q(t) \rightarrow Q(t+1)$	J	K
0 $\rightarrow$ 0	0	d
0 $\rightarrow$ 1	1	d
1 $\rightarrow$ 0	d	1
1 $\rightarrow$ 1	d	0

# Excitation table for the counter with JK flip-flops

	Present state $y_2y_1y_0$	Flip-flop inputs								Count $z_2z_1z_0$
		$w = 0$				$w = 1$				
		$Y_2Y_1Y_0$	$J_2K_2$	$J_1K_1$	$J_0K_0$	$Y_2Y_1Y_0$	$J_2K_2$	$J_1K_1$	$J_0K_0$	
A	000	000	0d	0d	0d	001	0d	0d	1d	000
B	001	001	0d	0d	d0	010	0d	1d	d1	001
C	010	010	0d	d0	0d	011	0d	d0	1d	010
D	011	011	0d	d0	d0	100	1d	d1	d1	011
E	100	100	d0	0d	0d	101	d0	0d	1d	100
F	101	101	d0	0d	d0	110	d0	1d	d1	101
G	110	110	d0	d0	0d	111	d0	d0	1d	110
H	111	111	d0	d0	d0	000	d1	d1	d1	111



# Excitation table for the counter with JK flip-flops

	Present state $y_2y_1y_0$	Flip-flop inputs								Count $z_2z_1z_0$
		$w = 0$				$w = 1$				
		$Y_2Y_1Y_0$	$J_2K_2$	$J_1K_1$	$J_0K_0$	$Y_2Y_1Y_0$	$J_2K_2$	$J_1K_1$	$J_0K_0$	
A	000	000	0d	0d	0d	001	0d	0d	1d	000
B	001	001	0d	0d	d0	010	0d	1d	d1	001
C	010	010	0d	d0	0d	011	0d	d0	1d	010
D	011	011	0d	d0	d0	100	1d	d1	d1	011
E	100	100	d0	0d	0d	101	d0	0d	1d	100
F	101	101	d0	0d	d0	110	d0	1d	d1	101
G	110	110	d0	d0	0d	111	d0	d0	1d	110
H	111	111	d0	d0	d0	000	d1	d1	d1	111

$Q(t) \rightarrow Q(t+1)$	J K
<b>0 → 0</b>	<b>0 d</b>
<b>0 → 1</b>	<b>1 d</b>
<b>1 → 0</b>	<b>d 1</b>
<b>1 → 1</b>	<b>d 0</b>

# Karnaugh maps for the first JK flip-flop

	Present state $y_2y_1y_0$	Flip-flop inputs								Count $z_2z_1z_0$
		$w = 0$				$w = 1$				
		$Y_2Y_1Y_0$	$J_2K_2$	$J_1K_1$	$J_0K_0$	$Y_2Y_1Y_0$	$J_2K_2$	$J_1K_1$	$J_0K_0$	
A	000	000	0d	0d	0d	001	0d	0d	1d	000
B	001	001	0d	0d	d0	010	0d	1d	d1	001
C	010	010	0d	d0	0d	011	0d	d0	1d	010
D	011	011	0d	d0	d0	100	1d	d1	d1	011
E	100	100	d0	0d	0d	101	d0	0d	1d	100
F	101	101	d0	0d	d0	110	d0	1d	d1	101
G	110	110	d0	d0	0d	111	d0	d0	1d	110
H	111	111	d0	d0	d0	000	d1	d1	d1	111

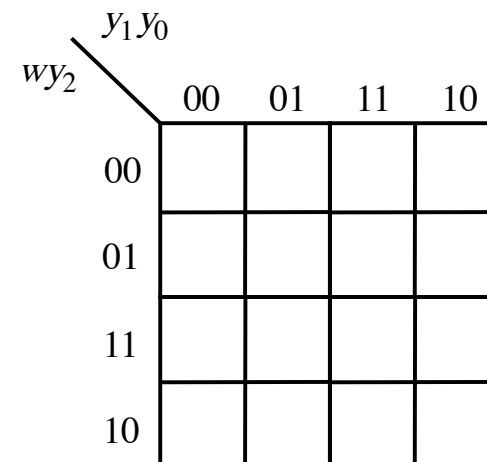
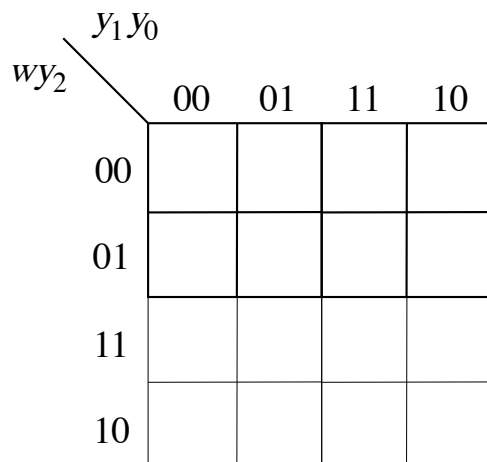

# Karnaugh maps for the first JK flip-flop

	Present state $y_2y_1y_0$	Flip-flop inputs								Count $z_2z_1z_0$
		$w = 0$				$w = 1$				
		$Y_2Y_1Y_0$	$J_2K_2$	$J_1K_1$	$J_0K_0$	$Y_2Y_1Y_0$	$J_2K_2$	$J_1K_1$	$J_0K_0$	
A	000	000	0d	0d	0d	001	0d	0d	1d	000
B	001	001	0d	0d	d0	010	0d	1d	d1	001
C	010	010	0d	d0	0d	011	0d	d0	1d	010
D	011	011	0d	d0	d0	100	1d	d1	d1	011
E	100	100	d0	0d	0d	101	d0	0d	1d	100
F	101	101	d0	0d	d0	110	d0	1d	d1	101
G	110	110	d0	d0	0d	111	d0	d0	1d	110
H	111	111	d0	d0	d0	000	d1	d1	d1	111

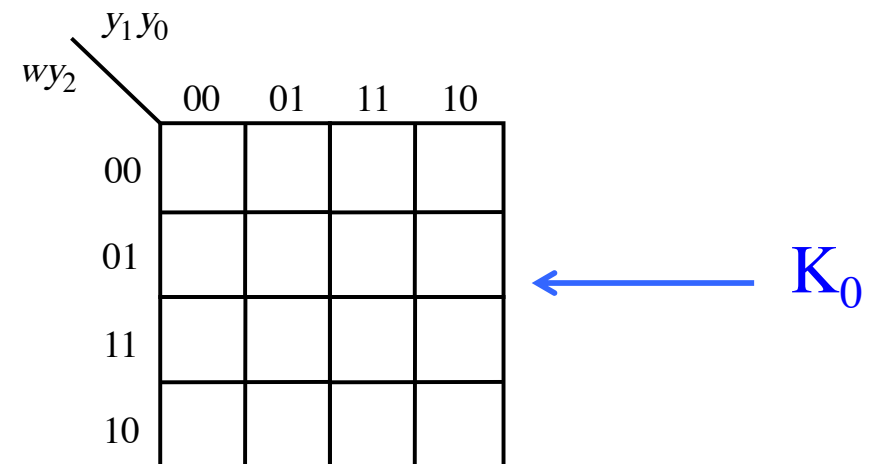
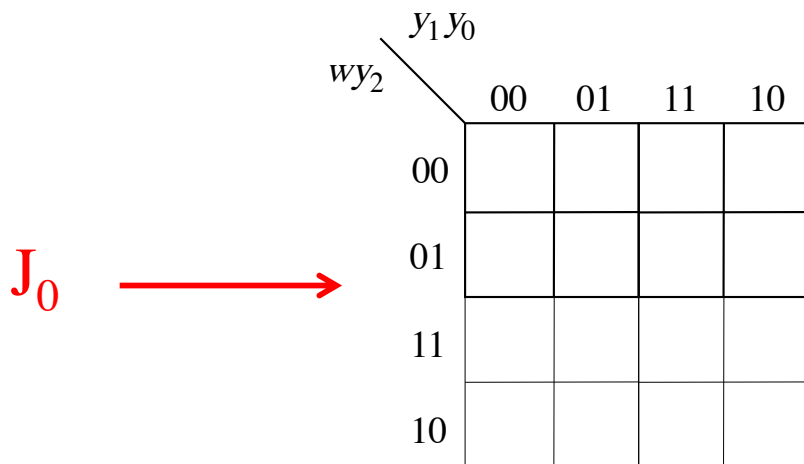

# Karnaugh maps for the first JK flip-flop

	Present state $y_2y_1y_0$	Flip-flop inputs								Count $z_2z_1z_0$
		$w = 0$				$w = 1$				
		$Y_2Y_1Y_0$	$J_2K_2$	$J_1K_1$	$J_0K_0$	$Y_2Y_1Y_0$	$J_2K_2$	$J_1K_1$	$J_0K_0$	
A	000	000	0d	0d	0d	001	0d	0d	1d	000
B	001	001	0d	0d	d0	010	0d	1d	d1	001
C	010	010	0d	d0	0d	011	0d	d0	1d	010
D	011	011	0d	d0	d0	100	1d	d1	d1	011
E	100	100	d0	0d	0d	101	d0	0d	1d	100
F	101	101	d0	0d	d0	110	d0	1d	d1	101
G	110	110	d0	d0	0d	111	d0	d0	1d	110
H	111	111	d0	d0	d0	000	d1	d1	d1	111

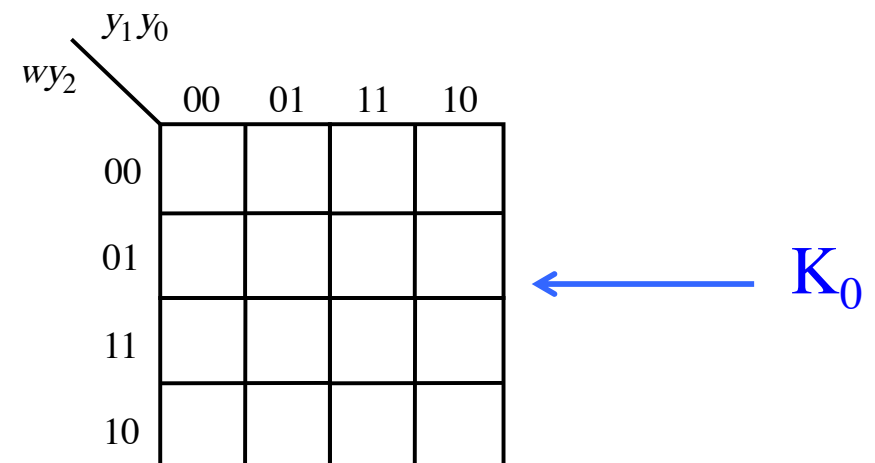
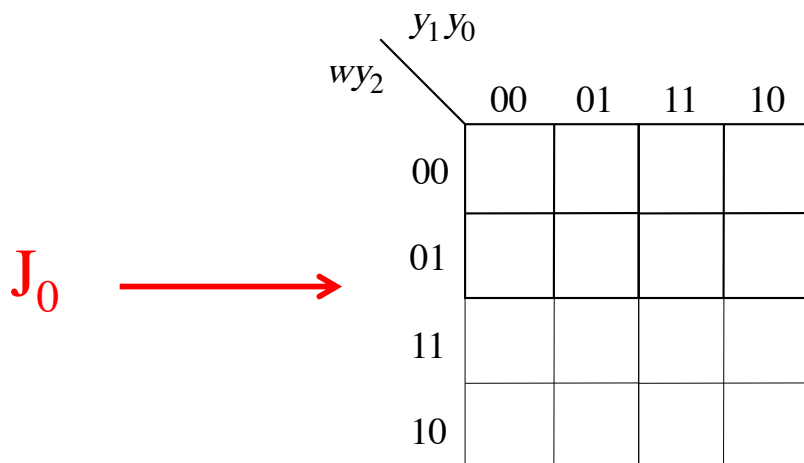

# Karnaugh maps for the first JK flip-flop

	Present state $y_2y_1y_0$	Flip-flop inputs								Count $z_2z_1z_0$
		$w = 0$				$w = 1$				
		$Y_2Y_1Y_0$	$J_2K_2$	$J_1K_1$	$J_0K_0$	$Y_2Y_1Y_0$	$J_2K_2$	$J_1K_1$	$J_0K_0$	
A	000	000	0d	0d	0d	001	0d	0d	1d	000
B	001	001	0d	0d	d0	010	0d	1d	d1	001
C	010	010	0d	d0	0d	011	0d	d0	1d	010
D	011	011	0d	d0	d0	100	1d	d1	d1	011
E	100	100	d0	0d	0d	101	d0	0d	1d	100
F	101	101	d0	0d	d0	110	d0	1d	d1	101
G	110	110	d0	d0	0d	111	d0	d0	1d	110
H	111	111	d0	d0	d0	000	d1	d1	d1	111

$J_0$  

	$y_1y_0$	00	01	11	10
$wy_2$	00	0	d	d	0
	01	0	d	d	0
	11	1	d	d	1
	10	1	d	d	1

  $K_0$

	$y_1y_0$	00	01	11	10
$wy_2$	00				
	01				
	11				
	10				

# Karnaugh maps for the first JK flip-flop

	Present state $y_2y_1y_0$	Flip-flop inputs								Count $z_2z_1z_0$
		$w = 0$				$w = 1$				
		$Y_2Y_1Y_0$	$J_2K_2$	$J_1K_1$	$J_0K_0$	$Y_2Y_1Y_0$	$J_2K_2$	$J_1K_1$	$J_0K_0$	
A	000	000	0d	0d	0d	001	0d	0d	1d	000
B	001	001	0d	0d	d0	010	0d	1d	d1	001
C	010	010	0d	d0	0d	011	0d	d0	1d	010
D	011	011	0d	d0	d0	100	1d	d1	d1	011
E	100	100	d0	0d	0d	101	d0	0d	1d	100
F	101	101	d0	0d	d0	110	d0	1d	d1	101
G	110	110	d0	d0	0d	111	d0	d0	1d	110
H	111	111	d0	d0	d0	000	d1	d1	d1	111

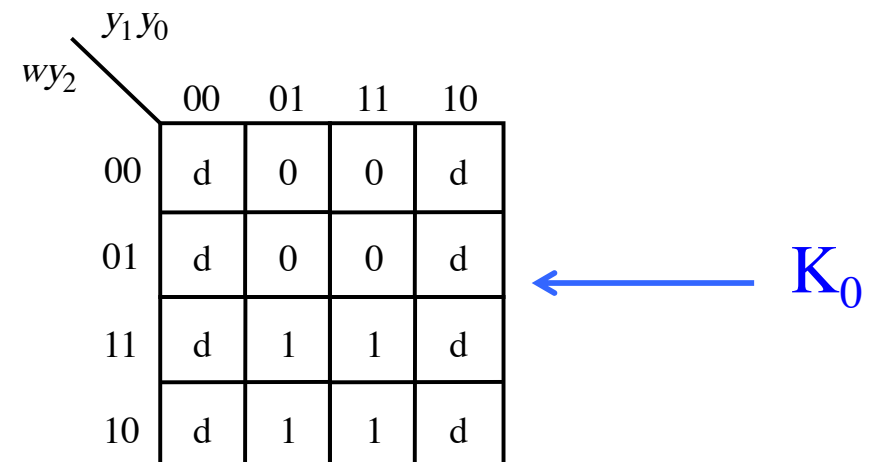
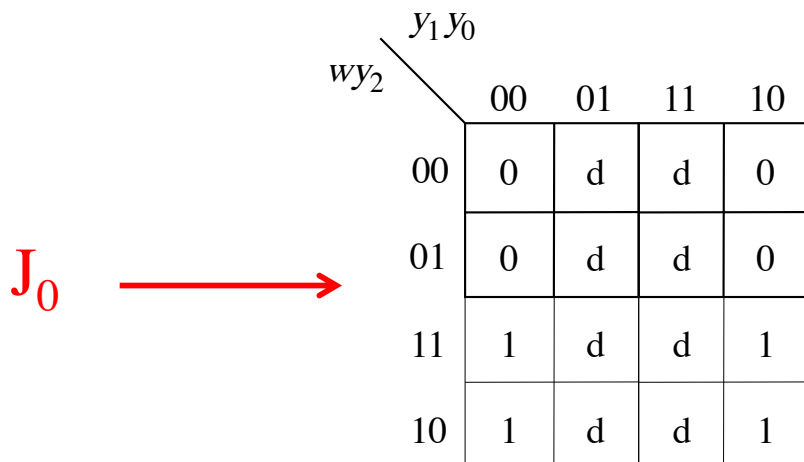

# Karnaugh maps for the first JK flip-flop

	Present state $y_2y_1y_0$	Flip-flop inputs								Count $z_2z_1z_0$
		$w = 0$				$w = 1$				
		$Y_2Y_1Y_0$	$J_2K_2$	$J_1K_1$	$J_0K_0$	$Y_2Y_1Y_0$	$J_2K_2$	$J_1K_1$	$J_0K_0$	
A	000	000	0d	0d	0d	001	0d	0d	1d	000
B	001	001	0d	0d	d0	010	0d	1d	d1	001
C	010	010	0d	d0	0d	011	0d	d0	1d	010
D	011	011	0d	d0	d0	100	1d	d1	d1	011
E	100	100	d0	0d	0d	101	d0	0d	1d	100
F	101	101	d0	0d	d0	110	d0	1d	d1	101
G	110	110	d0	d0	0d	111	d0	d0	1d	110
H	111	111	d0	d0	d0	000	d1	d1	d1	111

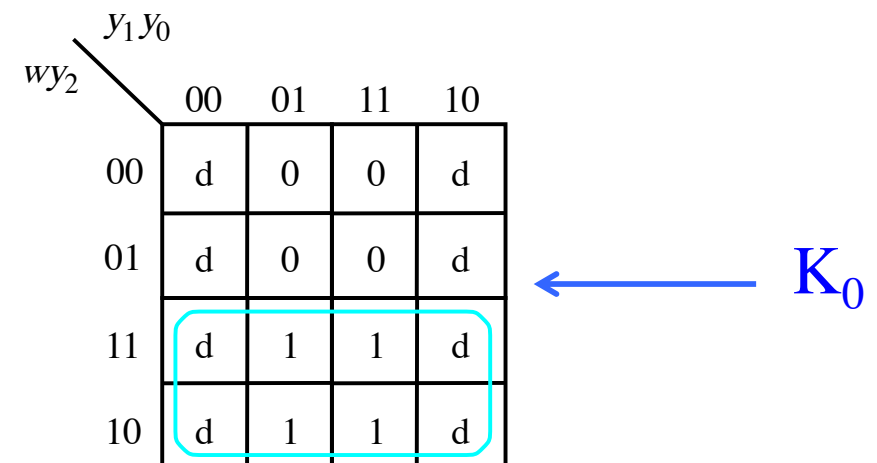
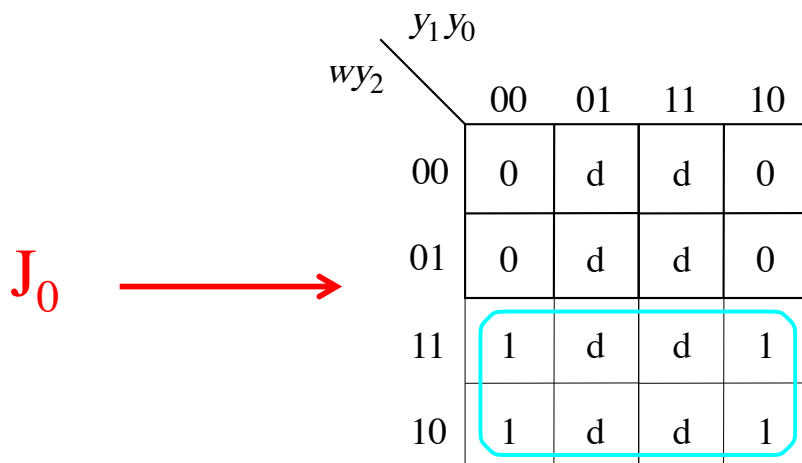

# Karnaugh maps for the first JK flip-flop

	Present state $y_2y_1y_0$	Flip-flop inputs								Count $z_2z_1z_0$
		$w = 0$				$w = 1$				
		$Y_2Y_1Y_0$	$J_2K_2$	$J_1K_1$	$J_0K_0$	$Y_2Y_1Y_0$	$J_2K_2$	$J_1K_1$	$J_0K_0$	
A	000	000	0d	0d	0d	001	0d	0d	1d	000
B	001	001	0d	0d	d0	010	0d	1d	d1	001
C	010	010	0d	d0	0d	011	0d	d0	1d	010
D	011	011	0d	d0	d0	100	1d	d1	d1	011
E	100	100	d0	0d	0d	101	d0	0d	1d	100
F	101	101	d0	0d	d0	110	d0	1d	d1	101
G	110	110	d0	d0	0d	111	d0	d0	1d	110
H	111	111	d0	d0	d0	000	d1	d1	d1	111

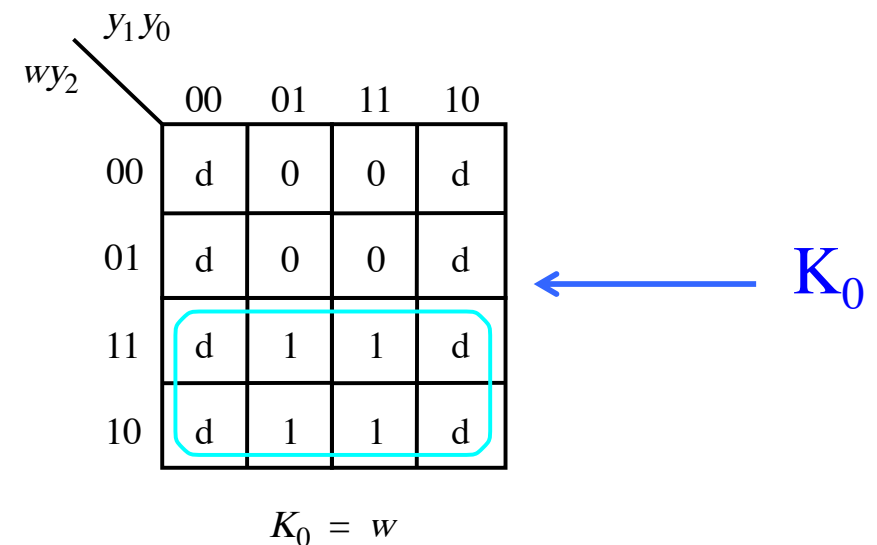
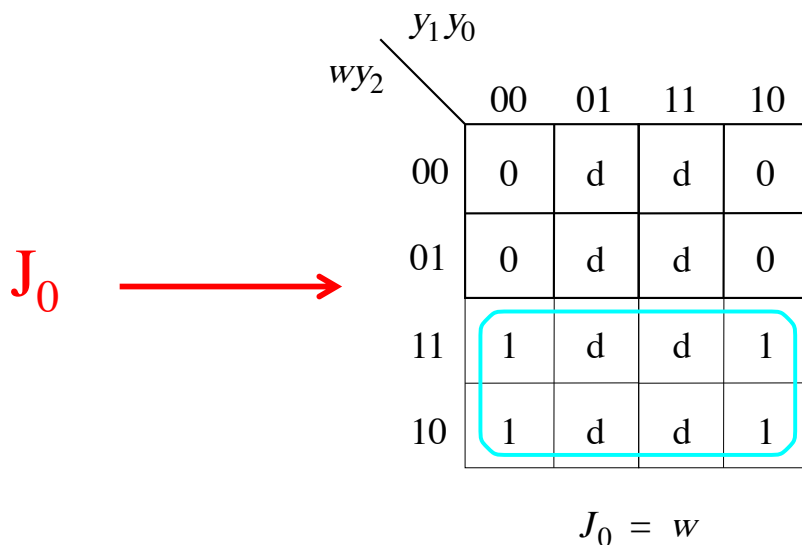



# Karnaugh maps for the first JK flip-flop

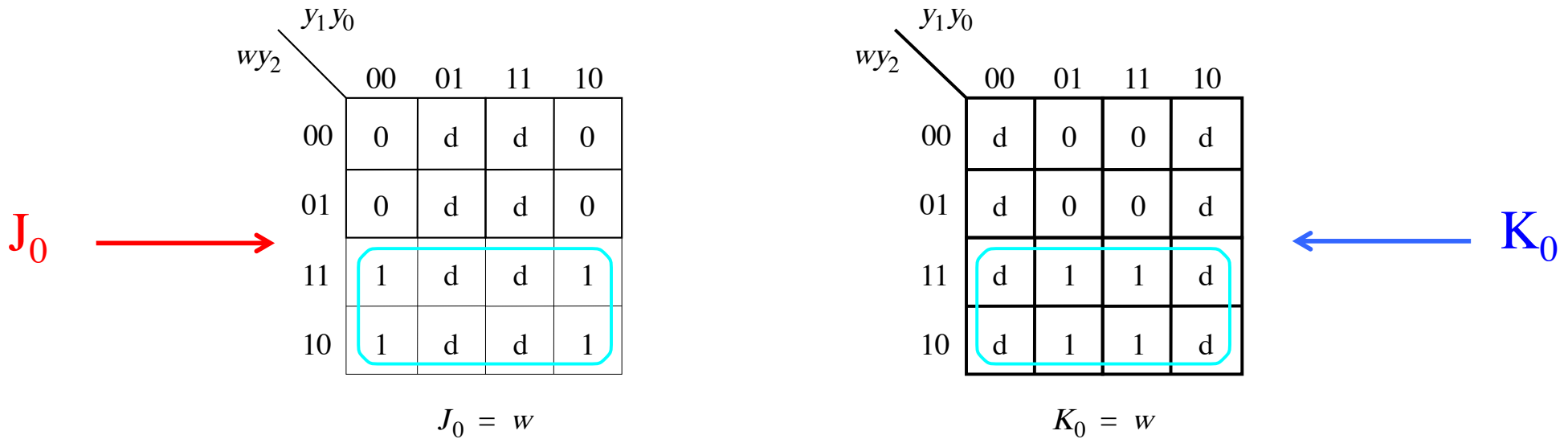

[ Figure 6.66 from the textbook ]

# Karnaugh maps for the second JK flip-flop

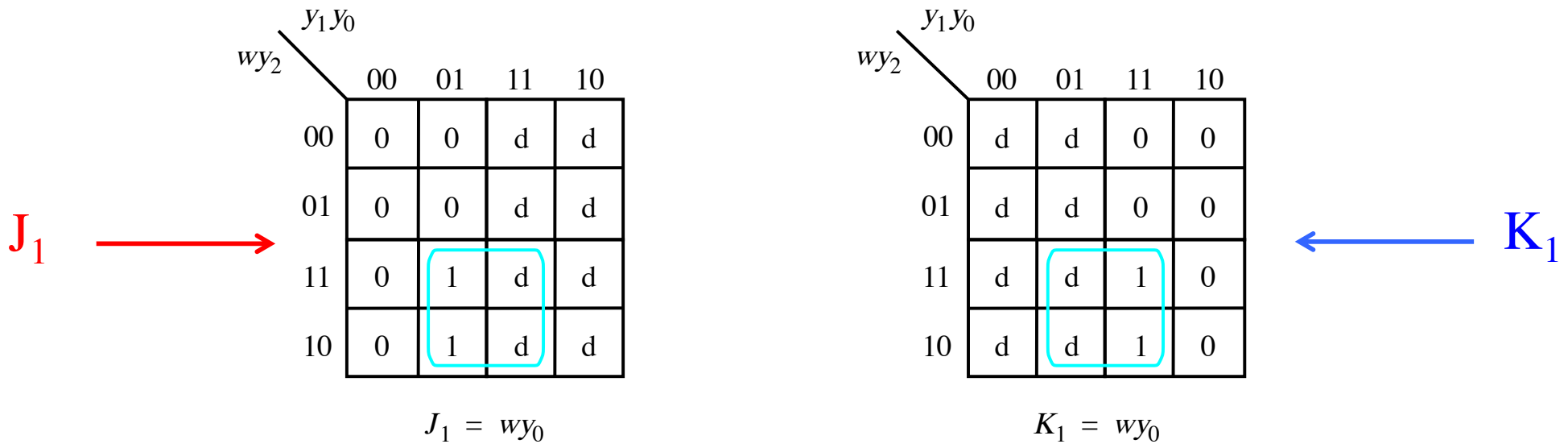

# Karnaugh maps for the third JK flip-flop

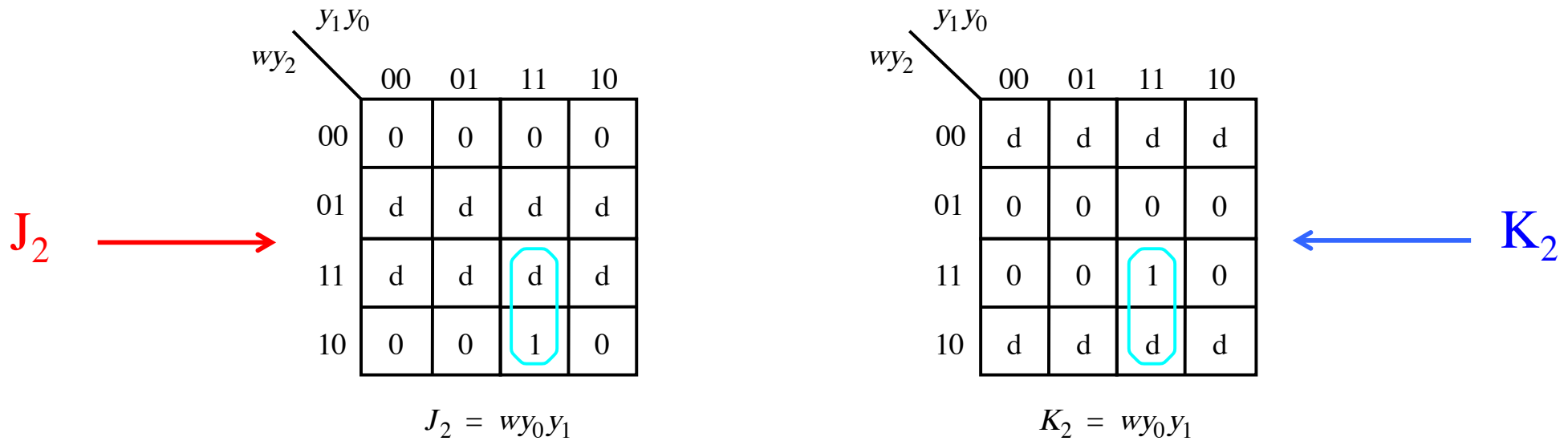

# Circuit diagram using JK flip-flops

$$J_0 = w$$

$$K_0 = w$$

$$J_1 = wy_0$$

$$K_1 = wy_0$$

$$J_2 = wy_0y_1$$

$$K_2 = wy_0y_1$$

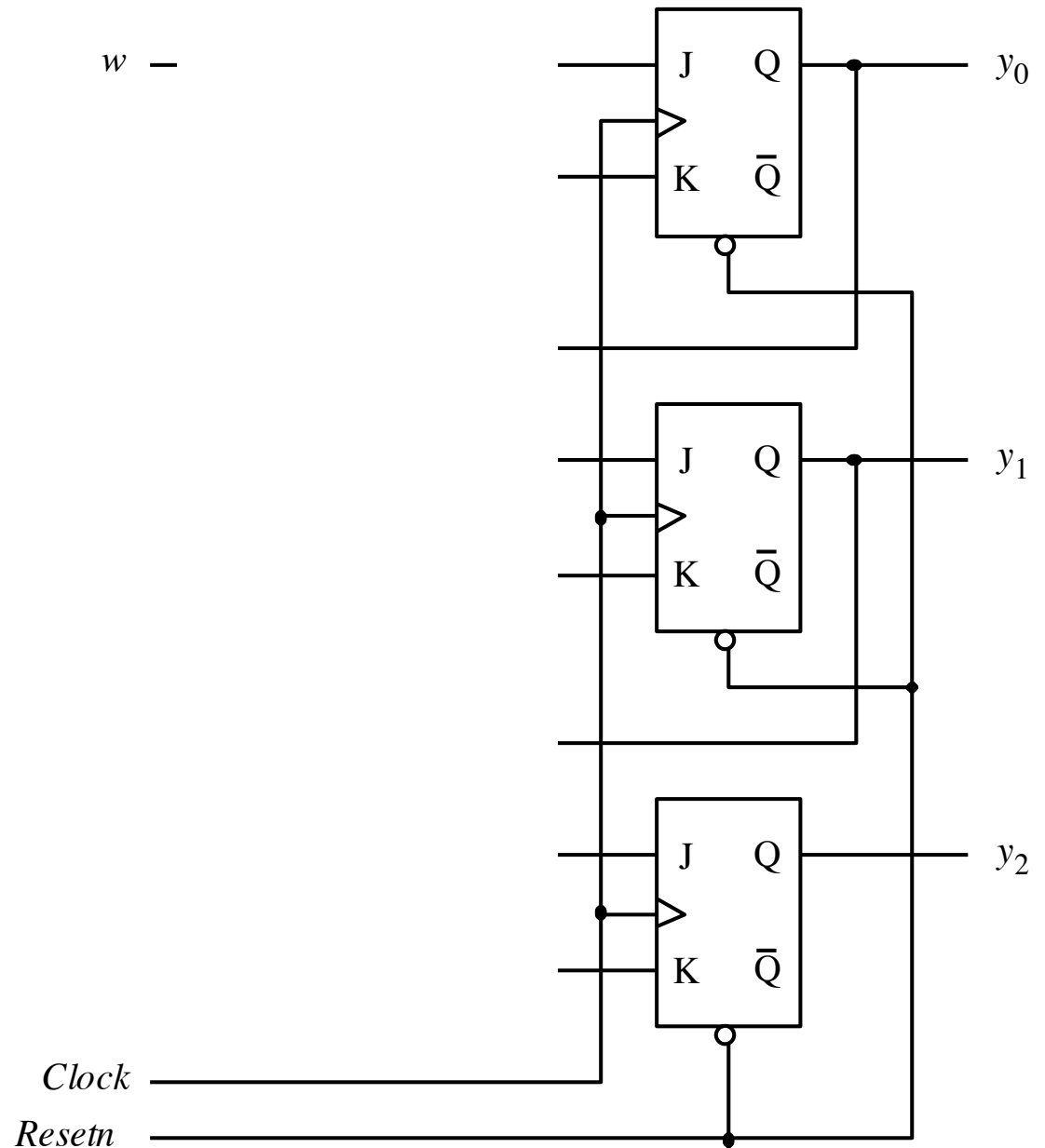

# Circuit diagram using JK flip-flops

$$J_0 = w$$

$$K_0 = w$$

$$J_1 = wy_0$$

$$K_1 = wy_0$$

$$J_2 = wy_0y_1$$

$$K_2 = wy_0y_1$$

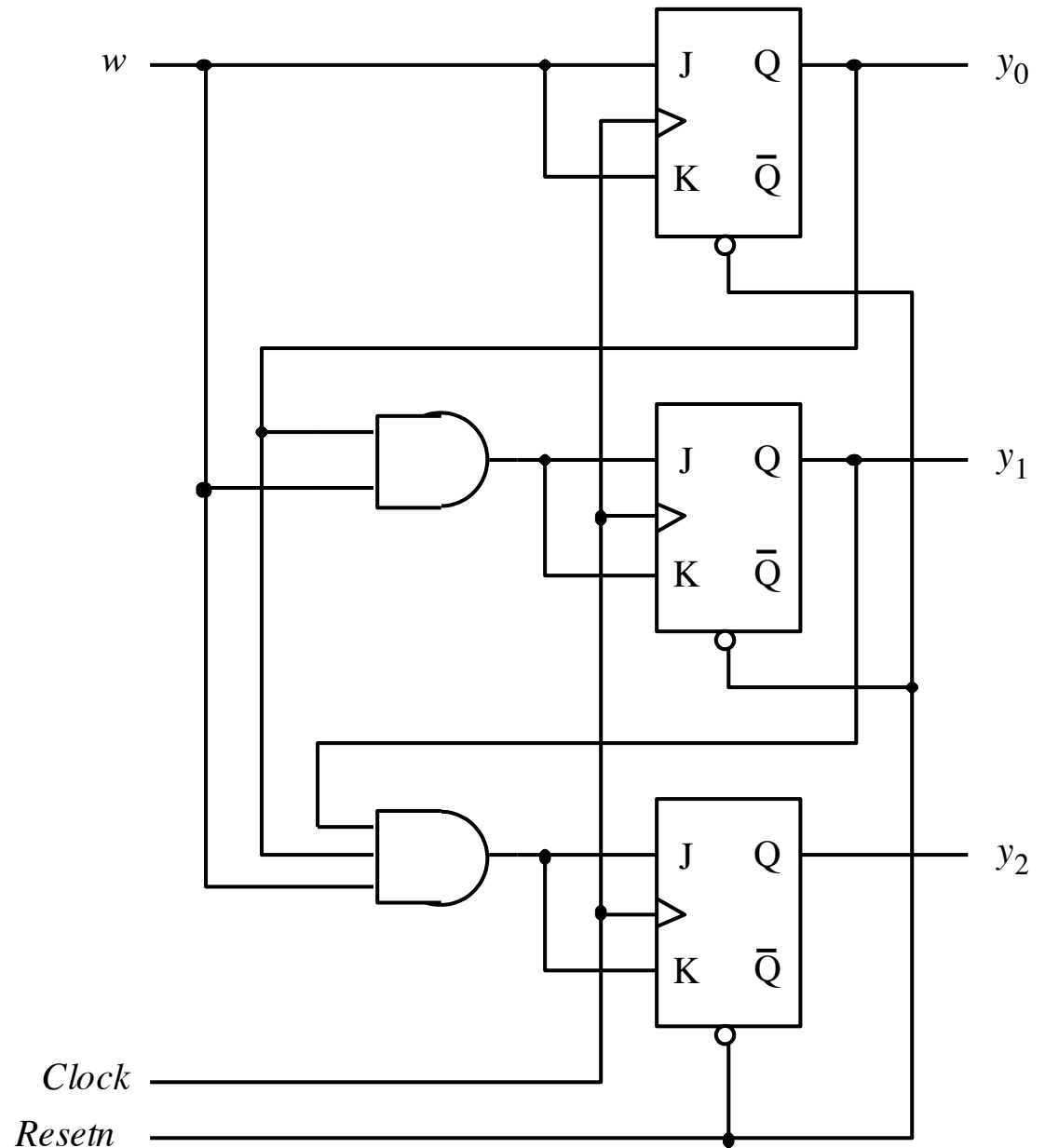

[ Figure 6.67 from the textbook ]

# Factored-form implementation of the counter

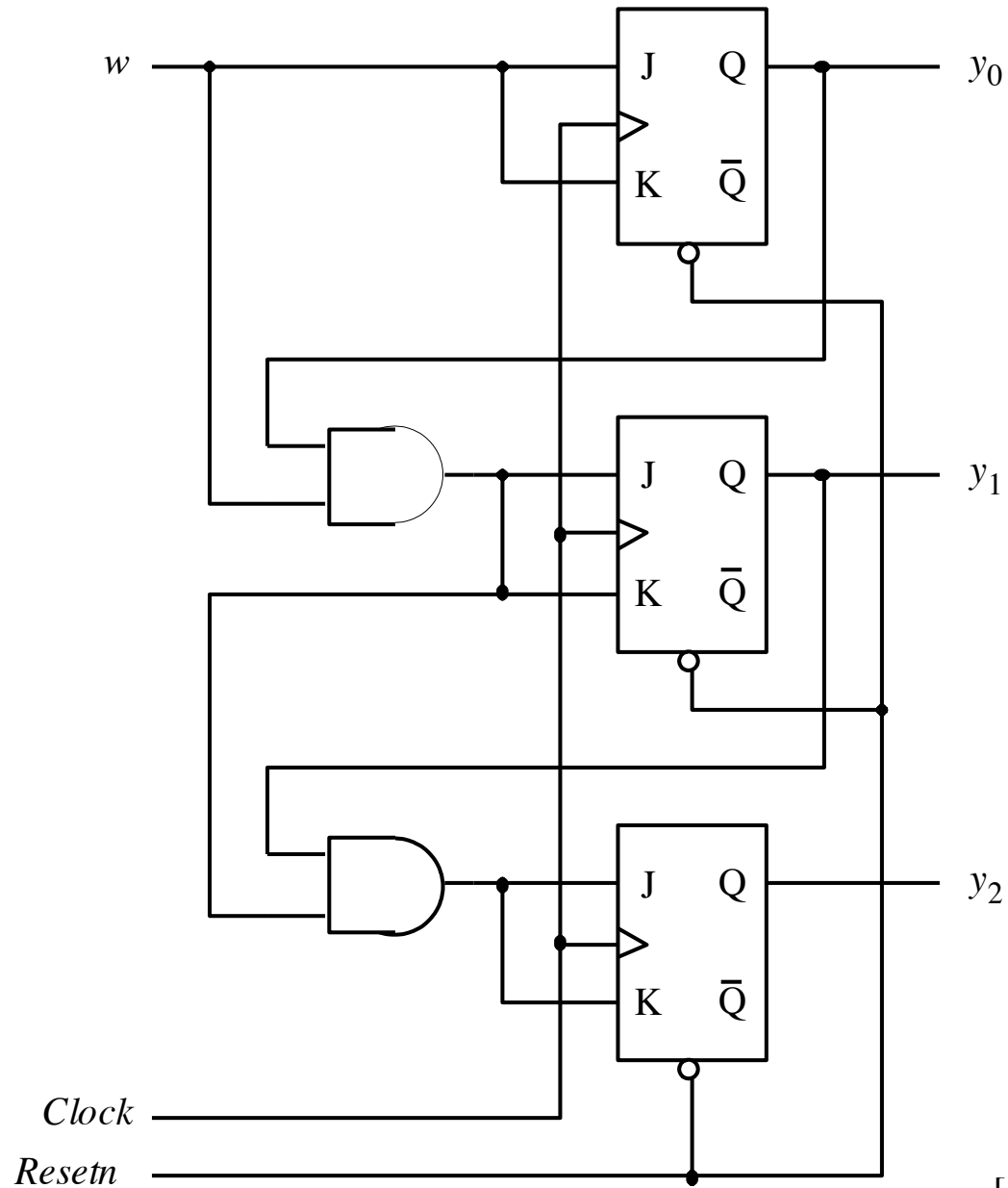

[ Figure 6.68 from the textbook ]

# **Another Example (A Different “Counter”)**

# Goal

- **Implement a 3-bit counter using the sequential circuit approach that counts the pulses on the input line  $w$ .**
- **The counter must count in the following sequence:  
0, 4, 2, 6, 1, 5, 3, 7, 0, 4, 2, ...**
- **The count must be represented directly by the flip-flop values. No extra gates are allowed.**
- **In other words, count =  $Q_2 Q_1 Q_0$**
- **The count changes based on the input signal  $w$ :**
  - **If  $w=0$ , then the count remains the same**
  - **If  $w=1$ , then the count is advanced by one**





# Goal



- Implement a 3-bit counter using the sequential circuit approach that counts the pulses on the input line  $w$ .
- The counter must count in the following sequence:  
0, 4, 2, 6, 1, 5, 3, 7, 0, 4, 2, ...
- The count must be represented directly by the flip-flop values. No extra gates are allowed.
- In other words,  $\text{count} = Q_2 Q_1 Q_0$
- The count changes based on the input signal  $w$ :
  - If  $w=0$ , then the count remains the same
  - If  $w=1$ , then the count is advanced by one

Clock =  $w$

**By flipping the order of the bits we get**

000		000
001		100
010		010
011		110
100		001
101		101
110		011
111		111

# By flipping the order of the bits we get

0	000		000	0
1	001		100	4
2	010		010	2
3	011		110	6
4	100		001	1
5	101		101	5
6	110		011	3
7	111		111	7

# State table for the counterlike example

Present state	Next state	Output $z_2z_1z_0$
A	B	000
B	C	100
C	D	010
D	E	110
E	F	001
F	G	101
G	H	011
H	A	111

# State-assigned table for this example

Present state $y_2y_1y_0$	Next state $Y_2Y_1Y_0$	Output $z_2z_1z_0$
000	100	000
100	010	100
010	110	010
110	001	110
001	101	001
101	011	101
011	111	011
111	000	111

# K-maps for $Y_2$ , $Y_1$ , and $Y_0$

Present state $y_2y_1y_0$	Next state $Y_2Y_1Y_0$	Output $z_2z_1z_0$
000	100	000
100	010	100
010	110	010
110	001	110
001	101	001
101	011	101
011	111	011
111	000	111

		$y_1y_0$			
		00	01	11	10
$y_2$	0				
	1				

# K-maps for $Y_2$ , $Y_1$ , and $Y_0$

Present state $y_2y_1y_0$	Next state $Y_2Y_1Y_0$	Output $z_2z_1z_0$
000	100	000
100	010	100
010	110	010
110	001	110
001	101	001
101	011	101
011	111	011
111	000	111

$y_2 \backslash y_1y_0$	00	01	11	10
0				
1				

Notice that these  
are scrambled

# K-maps for $Y_2$ , $Y_1$ , and $Y_0$

Present state $y_2y_1y_0$	Next state $Y_2Y_1Y_0$	Output $z_2z_1z_0$
000	100	000
100	010	100
010	110	010
110	001	110
001	101	001
101	011	101
011	111	011
111	000	111

$y_2 \backslash y_1y_0$	00	01	11	10
0				
1				

Notice that these  
are scrambled



# K-map for $Y_2$

Present state $y_2y_1y_0$	Next state $Y_2Y_1Y_0$	Output $z_2z_1z_0$
000	100	000
100	010	100
010	110	010
110	001	110
001	101	001
101	011	101
011	111	011
111	000	111

$y_2 \backslash y_1y_0$	00	01	11	10
0				
1				

# K-map for $Y_2$

Present state $y_2y_1y_0$	Next state $Y_2Y_1Y_0$	Output $z_2z_1z_0$
000	100	000
100	010	100
010	110	010
110	001	110
001	101	001
101	011	101
011	111	011
111	000	111

$y_2 \backslash y_1y_0$	00	01	11	10
0				
1				

# K-map for $Y_2$

Present state $y_2y_1y_0$	Next state $Y_2Y_1Y_0$	Output $z_2z_1z_0$
000	100	000
100	010	100
010	110	010
110	001	110
001	101	001
101	011	101
011	111	011
111	000	111

$y_2 \backslash y_1y_0$	00	01	11	10
0	1	1	1	1
1	0	0	0	0

# K-map for $Y_2$

Present state $y_2y_1y_0$	Next state $Y_2Y_1Y_0$	Output $z_2z_1z_0$
000	100	000
100	010	100
010	110	010
110	001	110
001	101	001
101	011	101
011	111	011
111	000	111

		$y_1y_0$			
		00	01	11	10
$y_2$	0	1	1	1	1
	1	0	0	0	0

$$Y_2 = \overline{y_2}$$

# K-map for $Y_1$

Present state $y_2y_1y_0$	Next state $Y_2Y_1Y_0$	Output $z_2z_1z_0$
000	100	000
100	010	100
010	110	010
110	001	110
001	101	001
101	011	101
011	111	011
111	000	111

$y_2 \backslash y_1y_0$	00	01	11	10
0				
1				

# K-map for $Y_1$

Present state $y_2y_1y_0$	Next state $Y_2Y_1Y_0$	Output $z_2z_1z_0$
000	100	000
100	010	100
010	110	010
110	001	110
001	101	001
101	011	101
011	111	011
111	000	111

$y_2 \backslash y_1y_0$	00	01	11	10
0				
1				

# K-map for $Y_1$

Present state $y_2y_1y_0$	Next state $Y_2Y_1Y_0$	Output $z_2z_1z_0$
000	100	000
100	010	100
010	110	010
110	001	110
001	101	001
101	011	101
011	111	011
111	000	111

$y_2 \backslash y_1y_0$	00	01	11	10
0	0	0	1	1
1	1	1	0	0

# K-map for $Y_1$

Present state $y_2y_1y_0$	Next state $Y_2Y_1Y_0$	Output $z_2z_1z_0$
000	100	000
100	010	100
010	110	010
110	001	110
001	101	001
101	011	101
011	111	011
111	000	111

		$y_1y_0$			
		00	01	11	10
$y_2$	0	0	0	1	1
	1	1	1	0	0

$$Y_1 = y_2\bar{y}_1 + \bar{y}_2y_1$$

XOR



# K-map for $Y_0$

Present state $y_2y_1y_0$	Next state $Y_2Y_1Y_0$	Output $z_2z_1z_0$
000	100	000
100	010	100
010	110	010
110	001	110
001	101	001
101	011	101
011	111	011
111	000	111

$y_2 \backslash y_1y_0$	00	01	11	10
0				
1				

# K-map for $Y_0$

Present state $y_2y_1y_0$	Next state $Y_2Y_1Y_0$	Output $z_2z_1z_0$
000	100	000
100	010	100
010	110	010
110	001	110
001	101	001
101	011	101
011	111	011
111	000	111

$y_2 \backslash y_1y_0$	00	01	11	10
0	0	1	1	0
1	0	1	0	1

# K-map for $Y_0$

Present state $y_2y_1y_0$	Next state $Y_2Y_1Y_0$	Output $z_2z_1z_0$
000	100	000
100	010	100
010	110	010
110	001	110
001	101	001
101	011	101
011	111	011
111	000	111

$y_2 \backslash y_1y_0$	00	01	11	10
0	0	1	1	0
1	0	1	0	1

$$Y_0 = \bar{y}_1y_0 + \bar{y}_2y_0 + y_2y_1\bar{y}_0$$

# K-map for $Y_0$

Present state $y_2 y_1 y_0$	Next state $Y_2 Y_1 Y_0$	Output $z_2 z_1 z_0$
000	100	000
100	010	100
010	110	010
110	001	110
001	101	001
101	011	101
011	111	011
111	000	111

$y_2 \backslash y_1 y_0$	00	01	11	10
0	0	1	1	0
1	0	1	0	1

$$\begin{aligned}
 Y_0 &= \bar{y}_1 y_0 + \bar{y}_2 y_0 + y_2 y_1 \bar{y}_0 \\
 &= (\bar{y}_1 + \bar{y}_2) y_0 + y_2 y_1 \bar{y}_0 \\
 &= (\overline{y_1 y_2}) y_0 + (y_2 y_1) \bar{y}_0 \\
 &= (y_1 y_2) \oplus y_0
 \end{aligned}$$

# Let's Draw the Circuit for this example

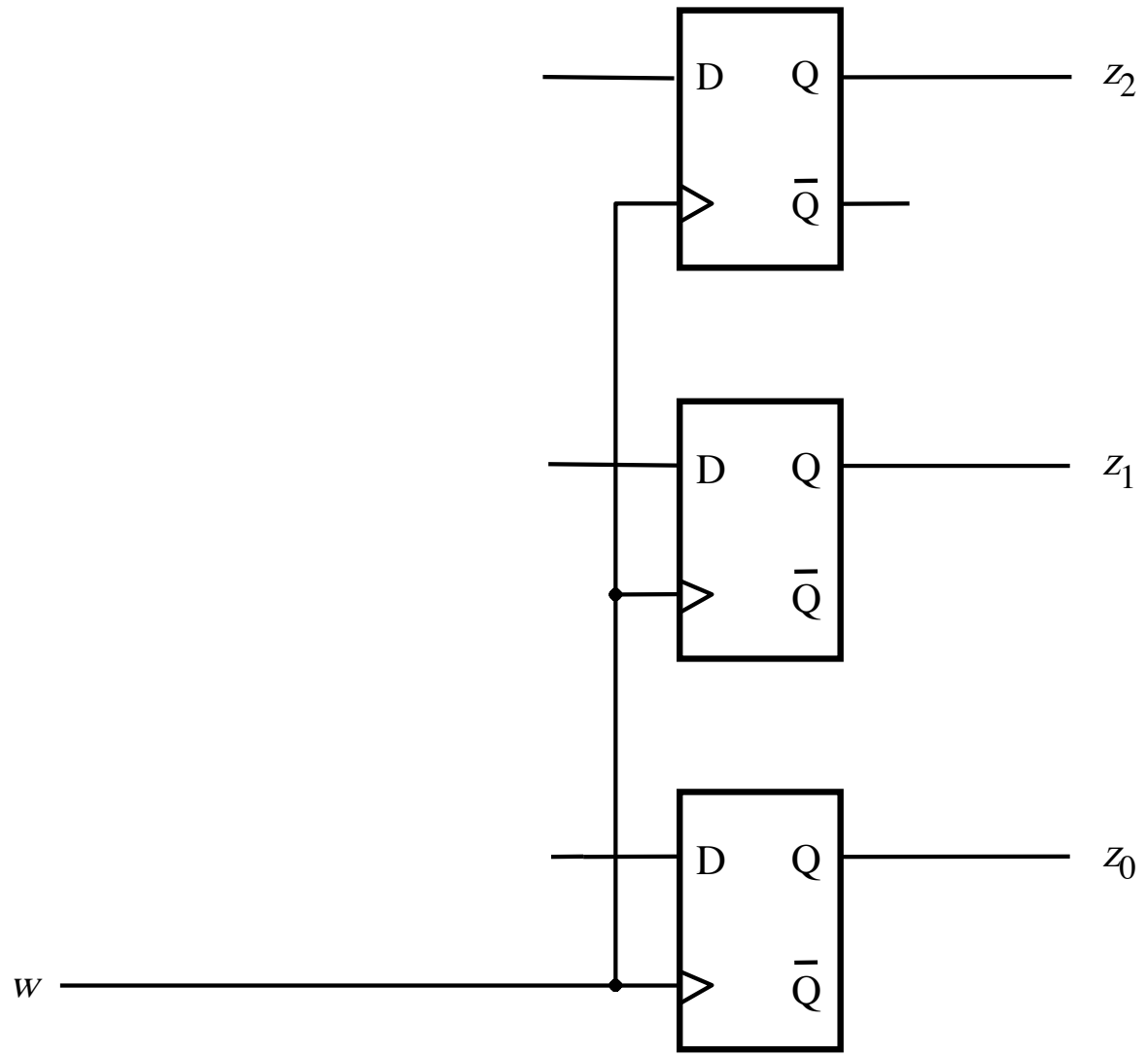

# Let's Draw the Circuit for this example

$$Y_2 = \overline{y_2}$$

$$Y_1 = y_1 \oplus y_2$$

$$Y_0 = (y_1 y_2) \oplus y_0$$

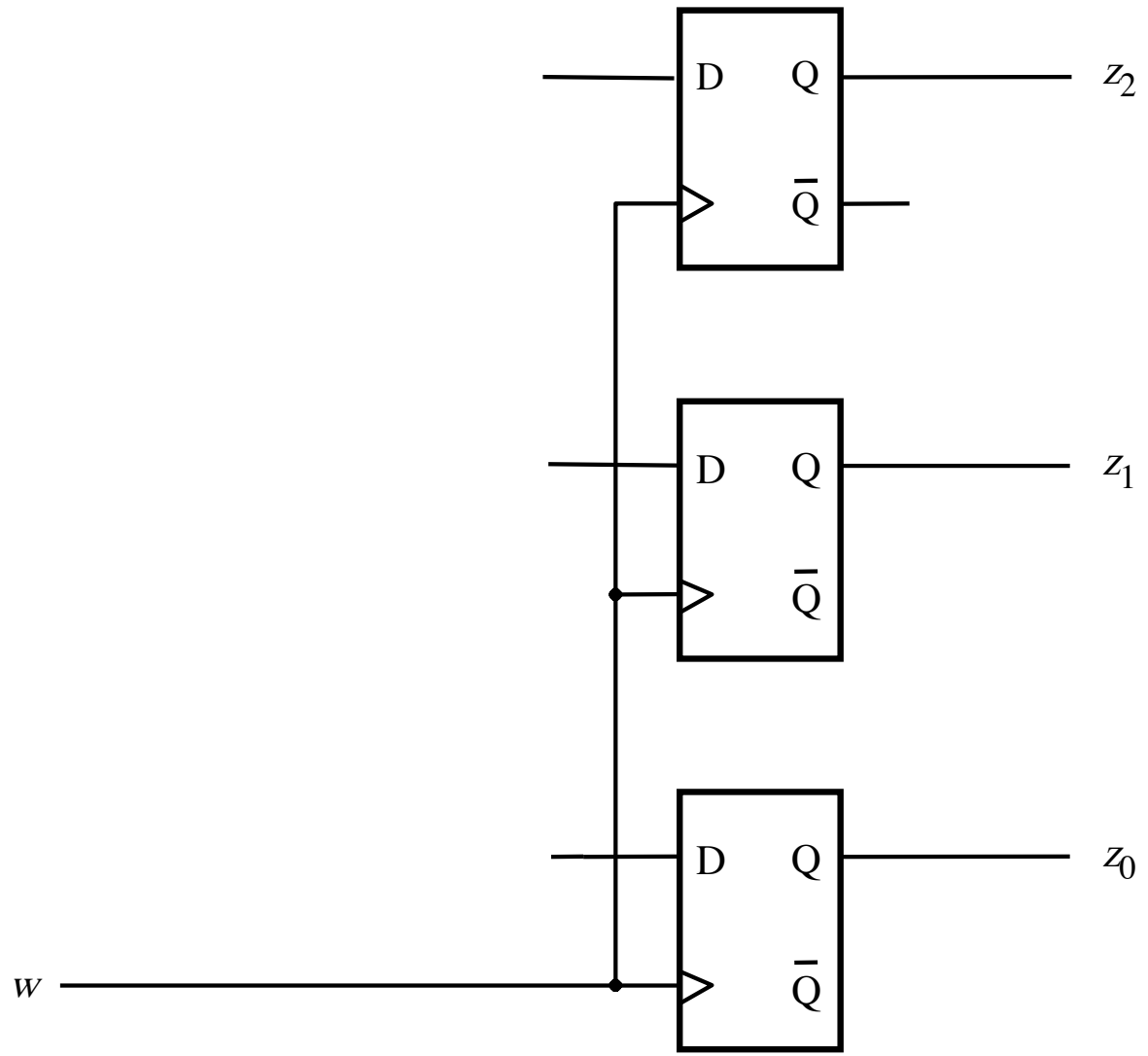

# The Circuit for this example

$$Y_2 = \overline{y_2}$$

$$Y_1 = y_1 \oplus y_2$$

$$Y_0 = (y_1 y_2) \oplus y_0$$

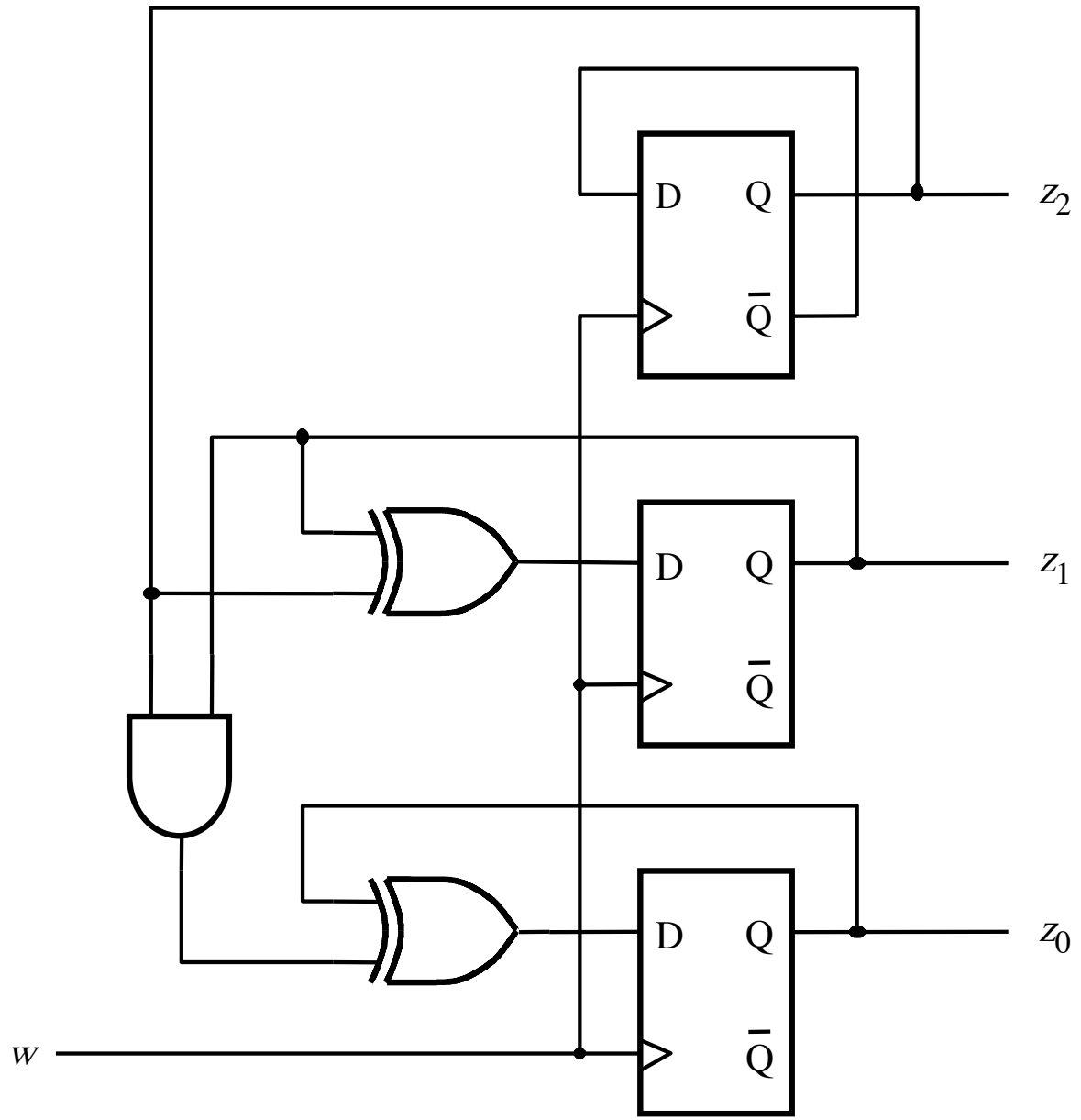

[ Figure 6.71 from the textbook ]

**Questions?**



**THE END**