



CprE 281: Digital Logic

Instructor: Alexander Stoytchev

<http://www.ece.iastate.edu/~alexs/classes/>

Multiplication

CprE 281: Digital Logic
Iowa State University, Ames, IA
Copyright © Alexander Stoytchev

Administrative Stuff

- **HW 6 is out**
- **It is due on Monday Oct 14 @ 4pm**

Quick Review

The Full-Adder Circuit

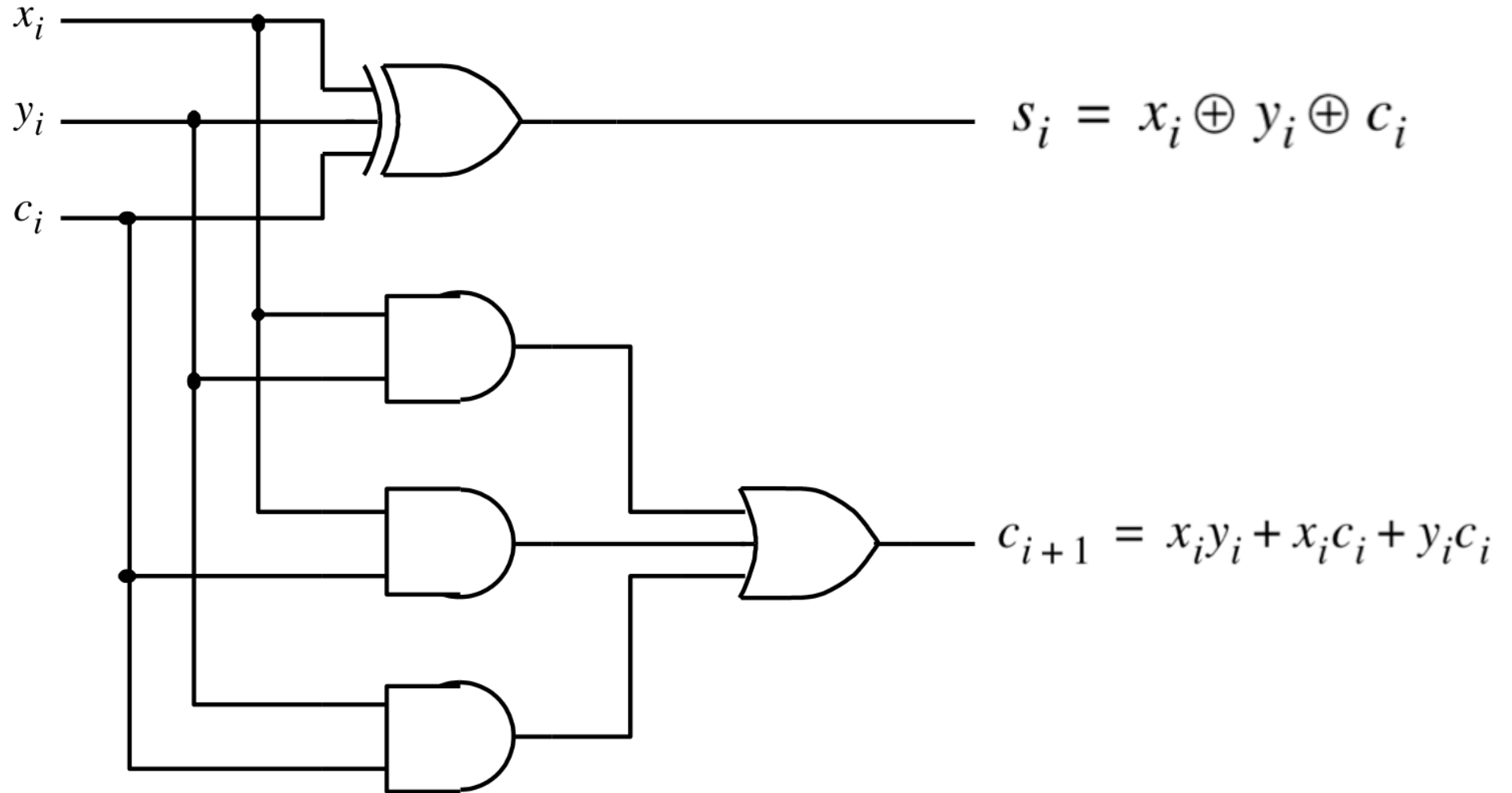

[Figure 3.3c from the textbook]

The Full-Adder Circuit

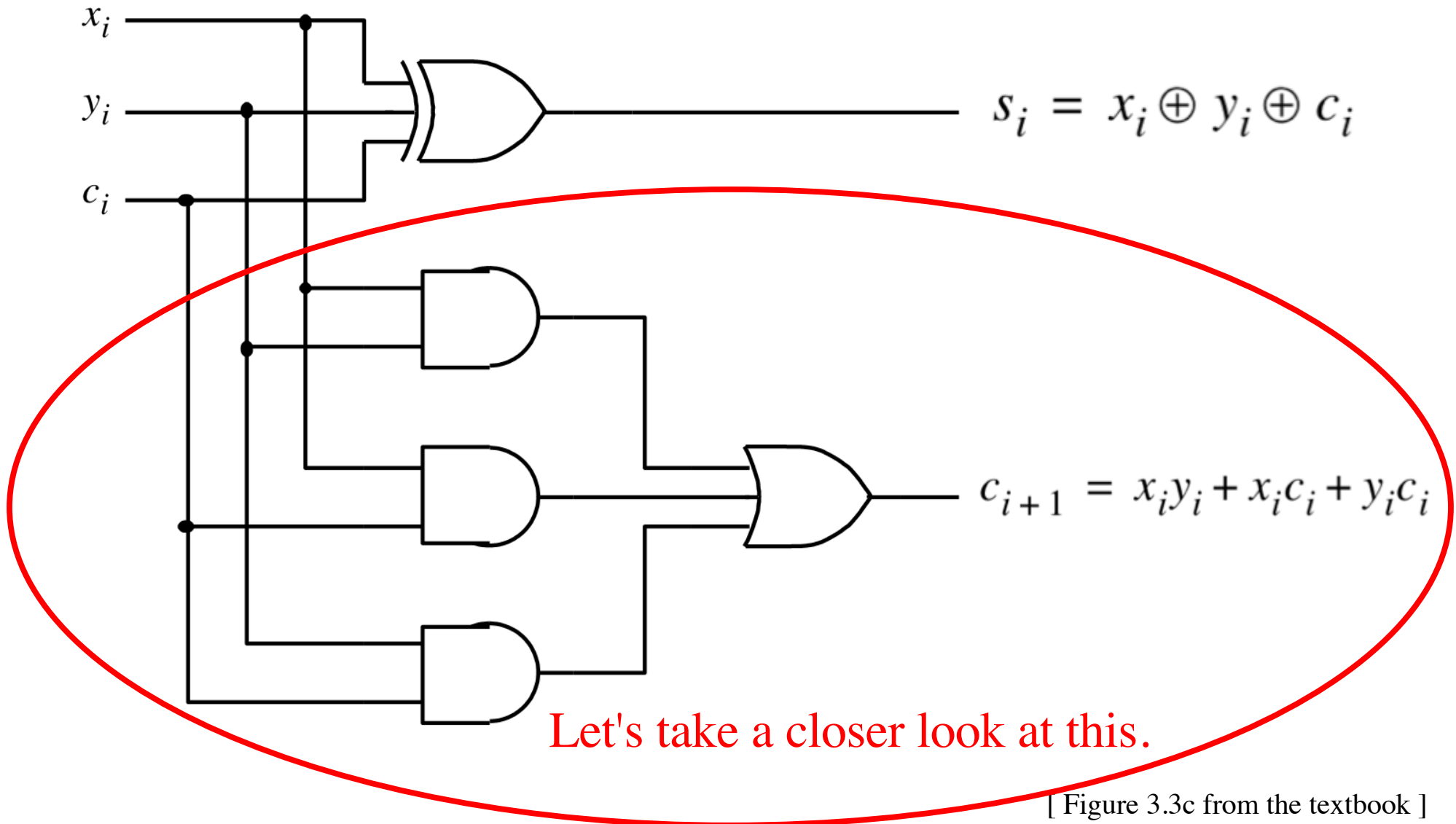

Another Way to Draw the Full-Adder Circuit

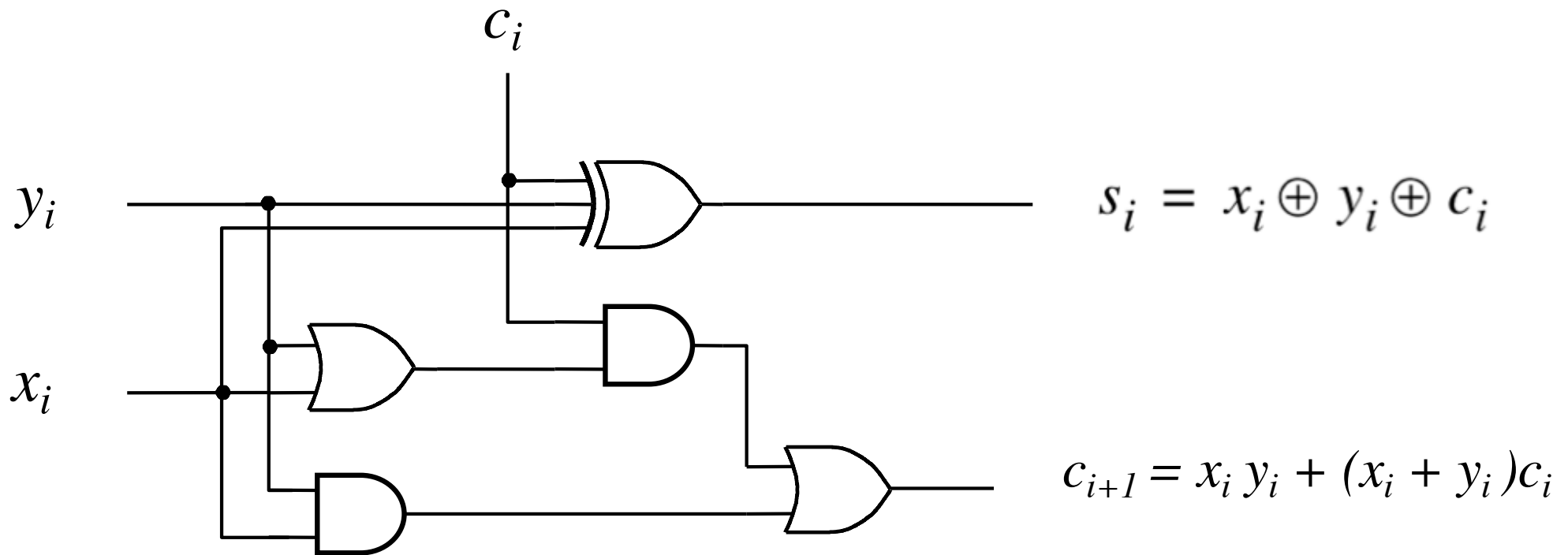

Decomposing the Carry Expression

$$c_{i+1} = x_i y_i + x_i c_i + y_i c_i$$

Decomposing the Carry Expression

$$c_{i+1} = x_i y_i + x_i c_i + y_i c_i$$

$$c_{i+1} = x_i y_i + (x_i + y_i) c_i$$

Decomposing the Carry Expression

$$C_{i+1} = x_i y_i + x_i c_i + y_i c_i$$

$$C_{i+1} = x_i y_i + (x_i + y_i) c_i$$

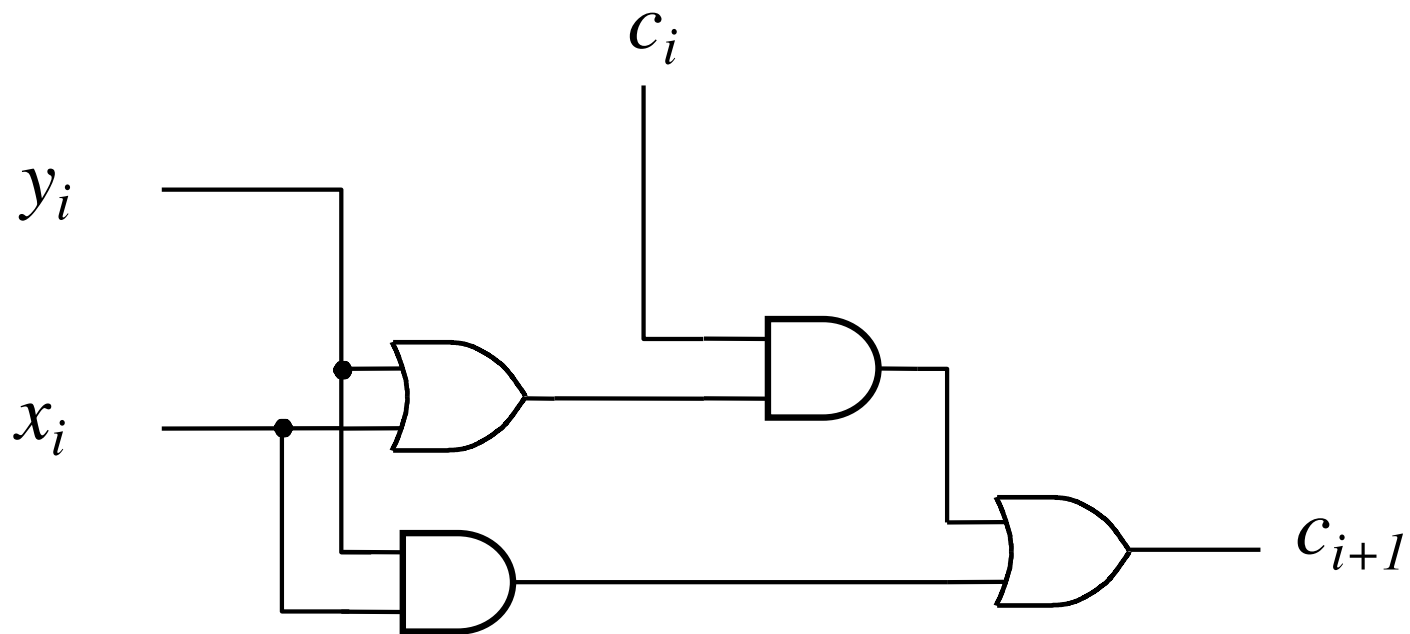

Another Way to Draw the Full-Adder Circuit

$$C_{i+1} = x_i y_i + x_i c_i + y_i c_i$$

$$C_{i+1} = x_i y_i + (x_i + y_i) c_i$$

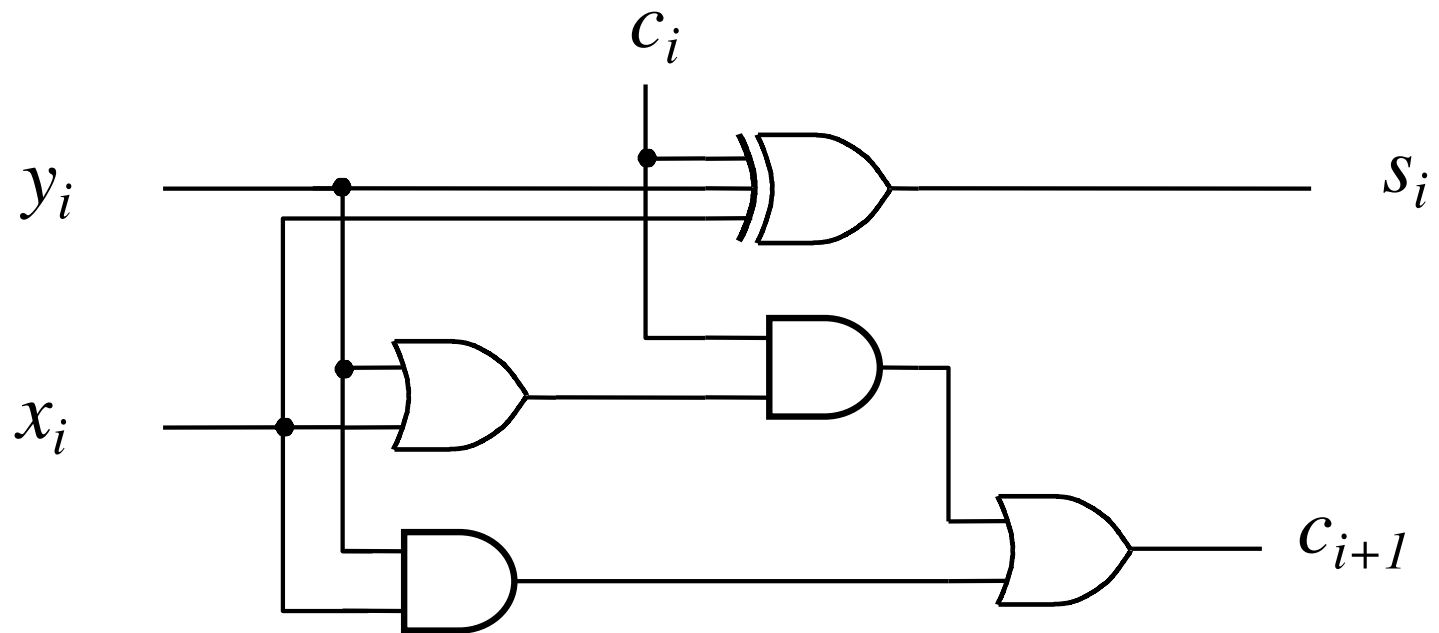

Another Way to Draw the Full-Adder Circuit

$$C_{i+1} = x_i y_i + (x_i + y_i)C_i$$

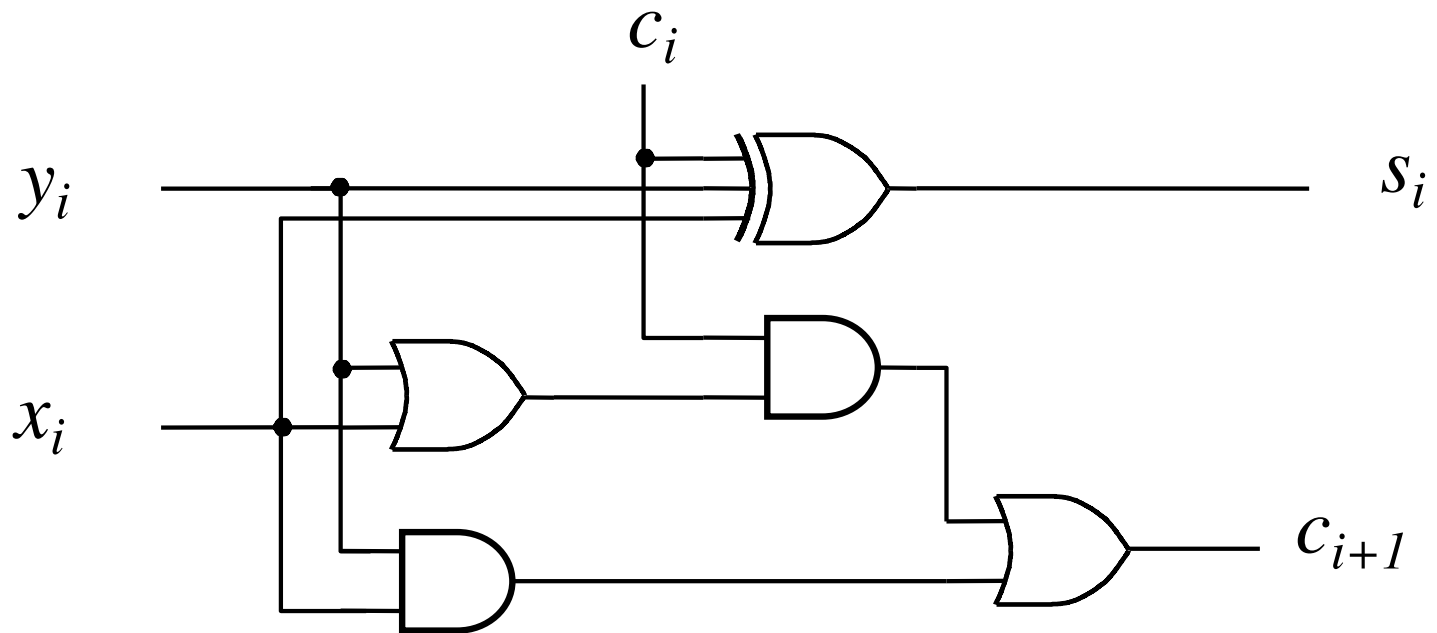

Another Way to Draw the Full-Adder Circuit

$$C_{i+1} = \underbrace{x_i y_i}_{g_i} + \underbrace{(x_i + y_i)}_{p_i} C_i$$

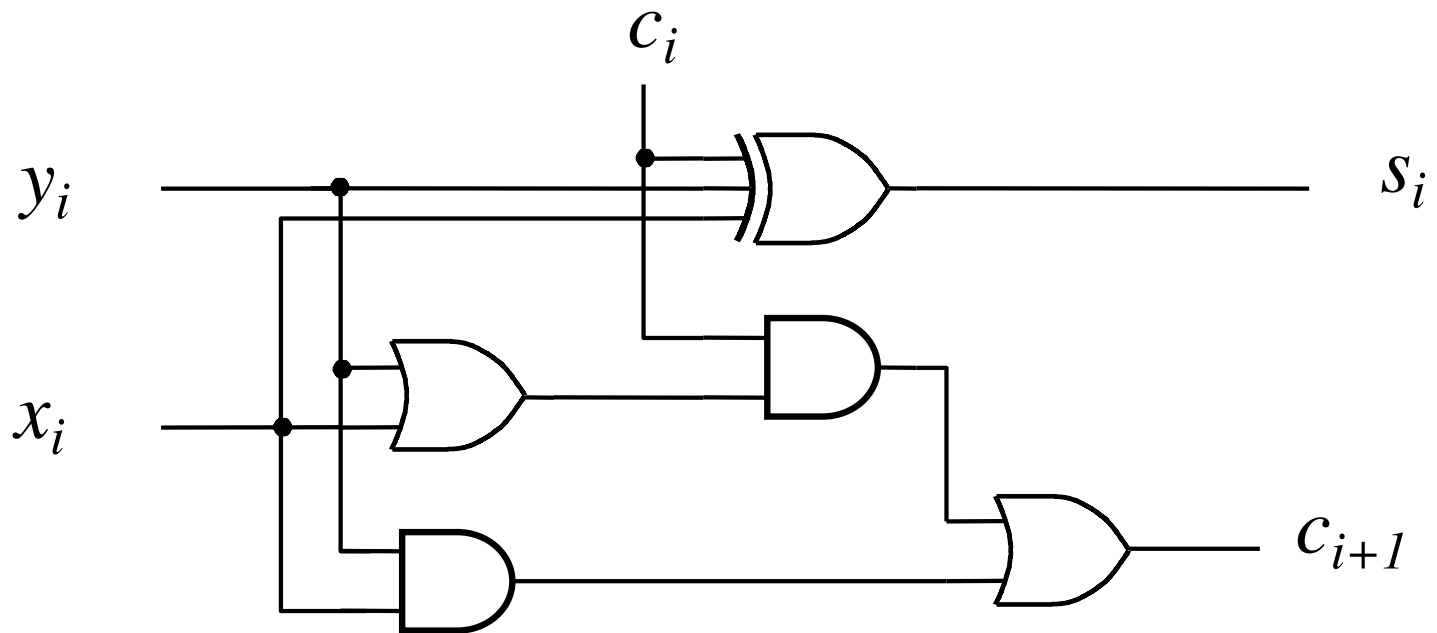

Another Way to Draw the Full-Adder Circuit

$$C_{i+1} = \underbrace{x_i y_i}_{g_i} + \underbrace{(x_i + y_i)}_{P_i} C_i$$

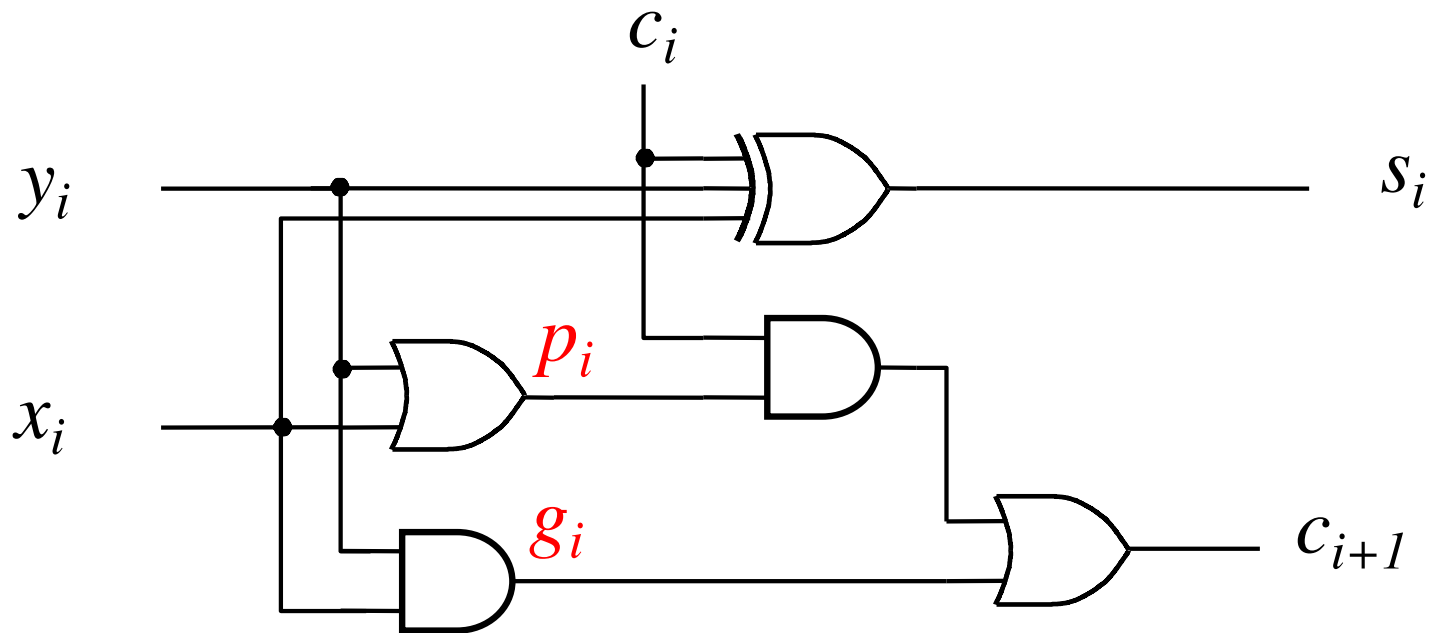

Yet Another Way to Draw It (Just Rotate It)

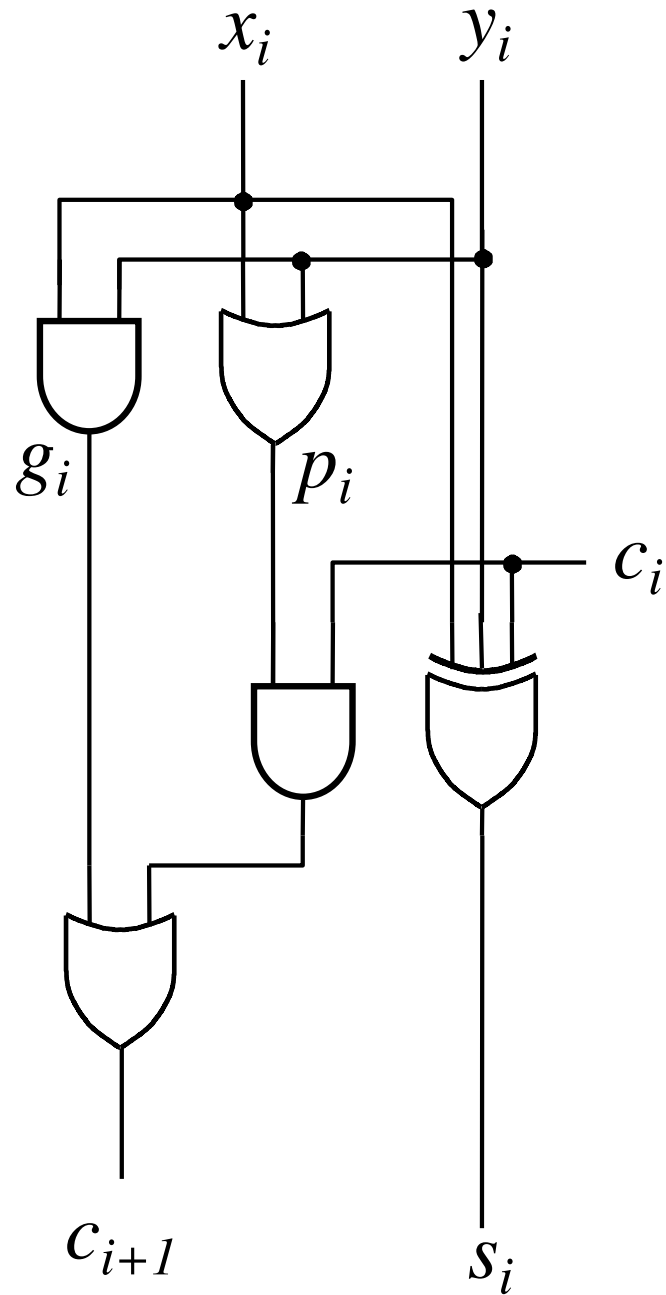

Now we can Build a Ripple-Carry Adder

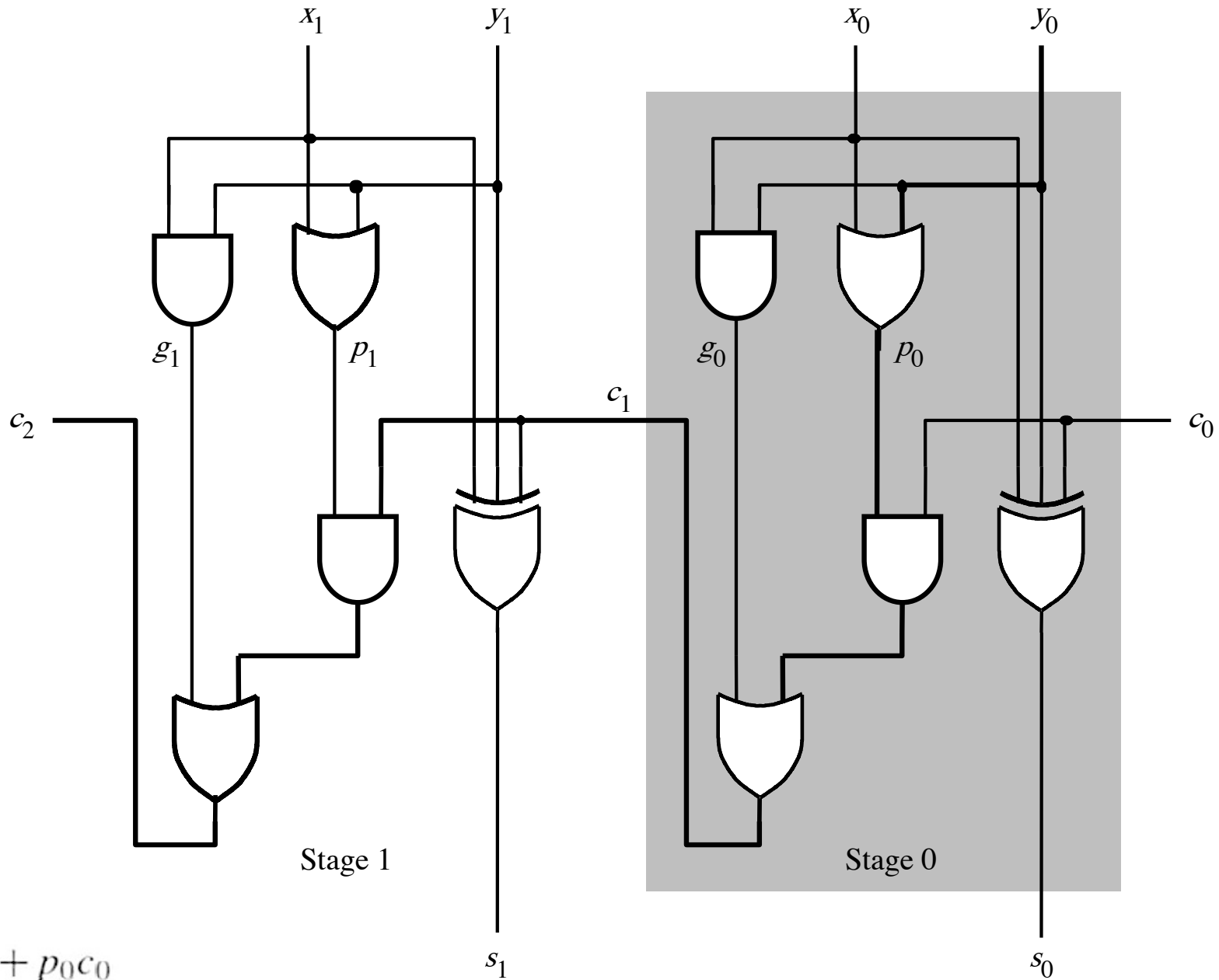

$$c_1 = g_0 + p_0 c_0$$

$$c_2 = g_1 + p_1 g_0 + p_1 p_0 c_0$$

[Figure 3.14 from the textbook]

Now we can Build a Ripple-Carry Adder

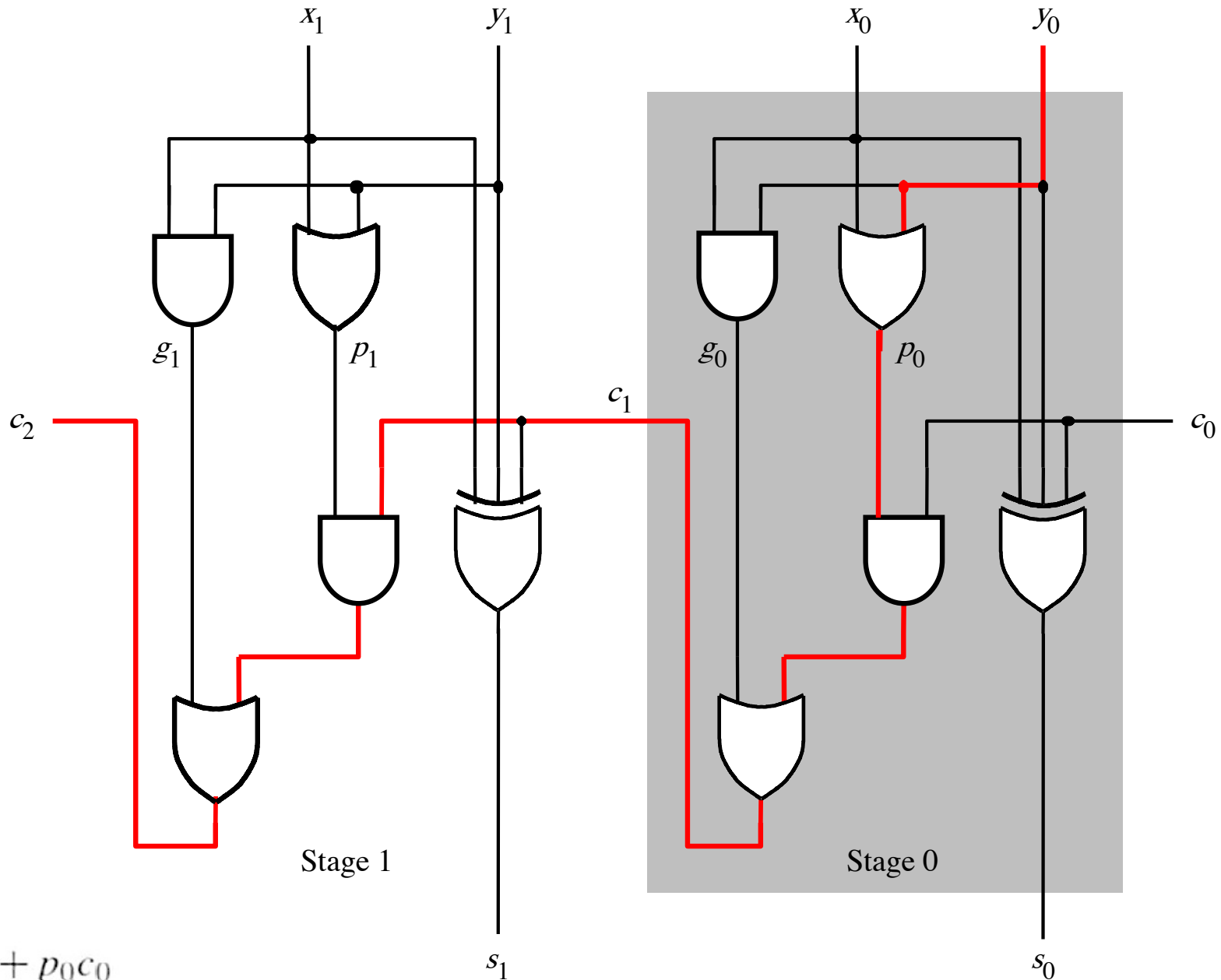

$$c_1 = g_0 + p_0 c_0$$

$$c_2 = g_1 + p_1 g_0 + p_1 p_0 c_0$$

[Figure 3.14 from the textbook]

The delay is 5 gates (1+2+2)

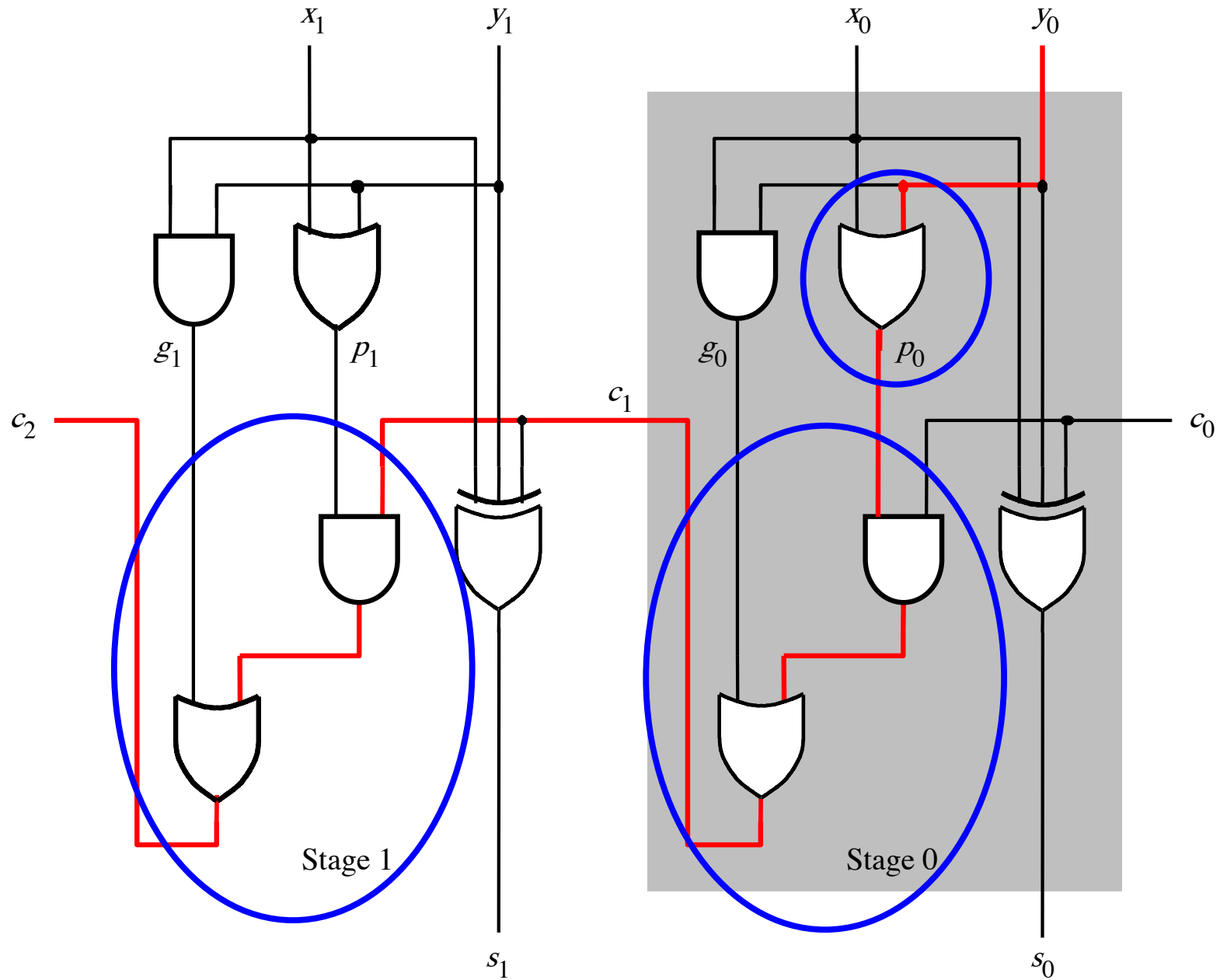

n-bit ripple-carry adder: $2n+1$ gate delays

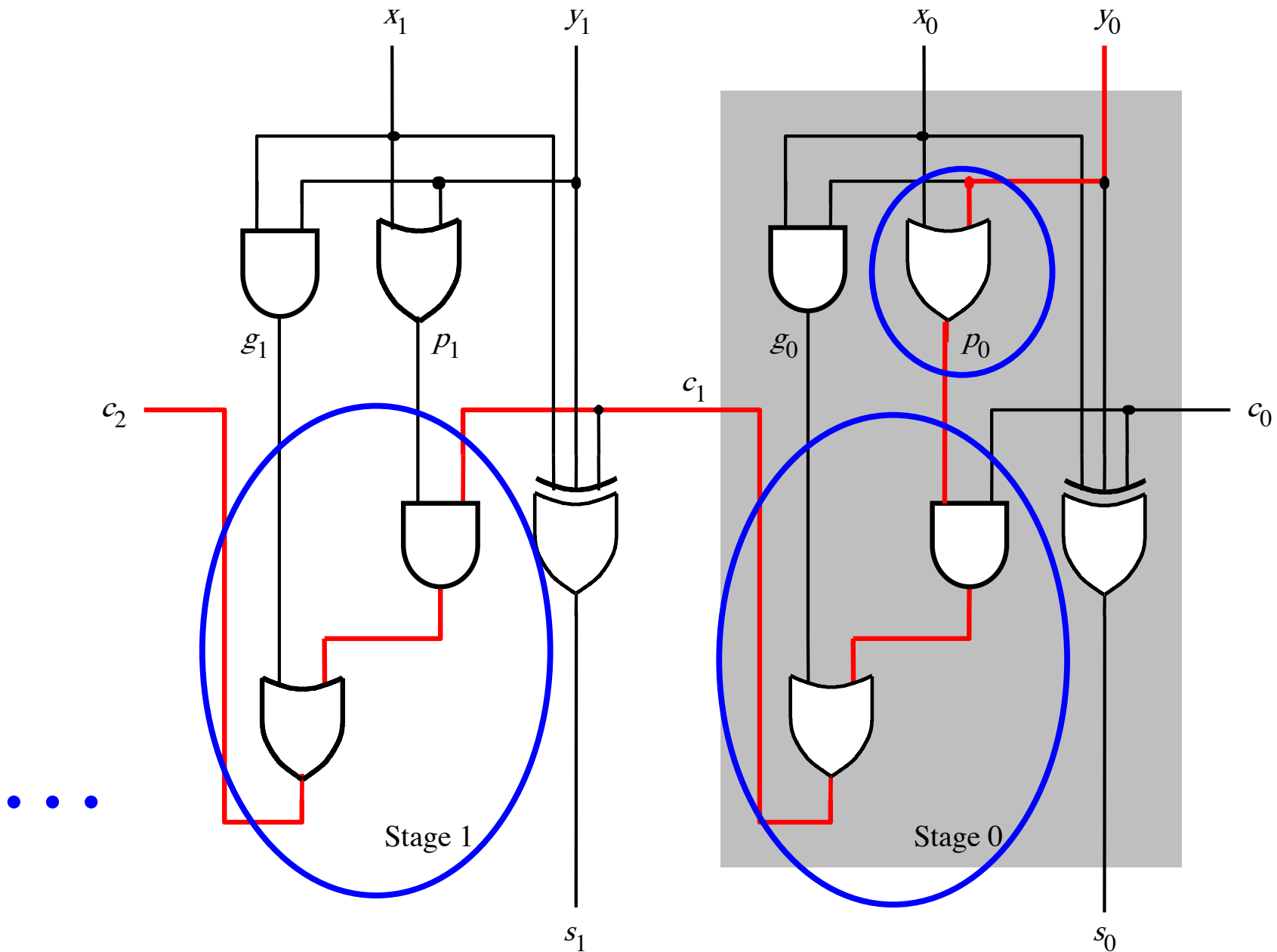

Decomposing the Carry Expression

$$c_{i+1} = x_i y_i + x_i c_i + y_i c_i$$

$$c_{i+1} = \underbrace{x_i y_i}_{g_i} + \underbrace{(x_i + y_i)}_{p_i} c_i$$

$$c_{i+1} = g_i + p_i c_i$$

$$c_{i+1} = g_i + p_i (g_{i-1} + p_{i-1} c_{i-1})$$

$$= g_i + p_i g_{i-1} + p_i p_{i-1} c_{i-1}$$

Carry for the first two stages

$$c_1 = g_0 + p_0 c_0$$

$$c_2 = g_1 + p_1 g_0 + p_1 p_0 c_0$$

The first two stages of a carry-lookahead adder

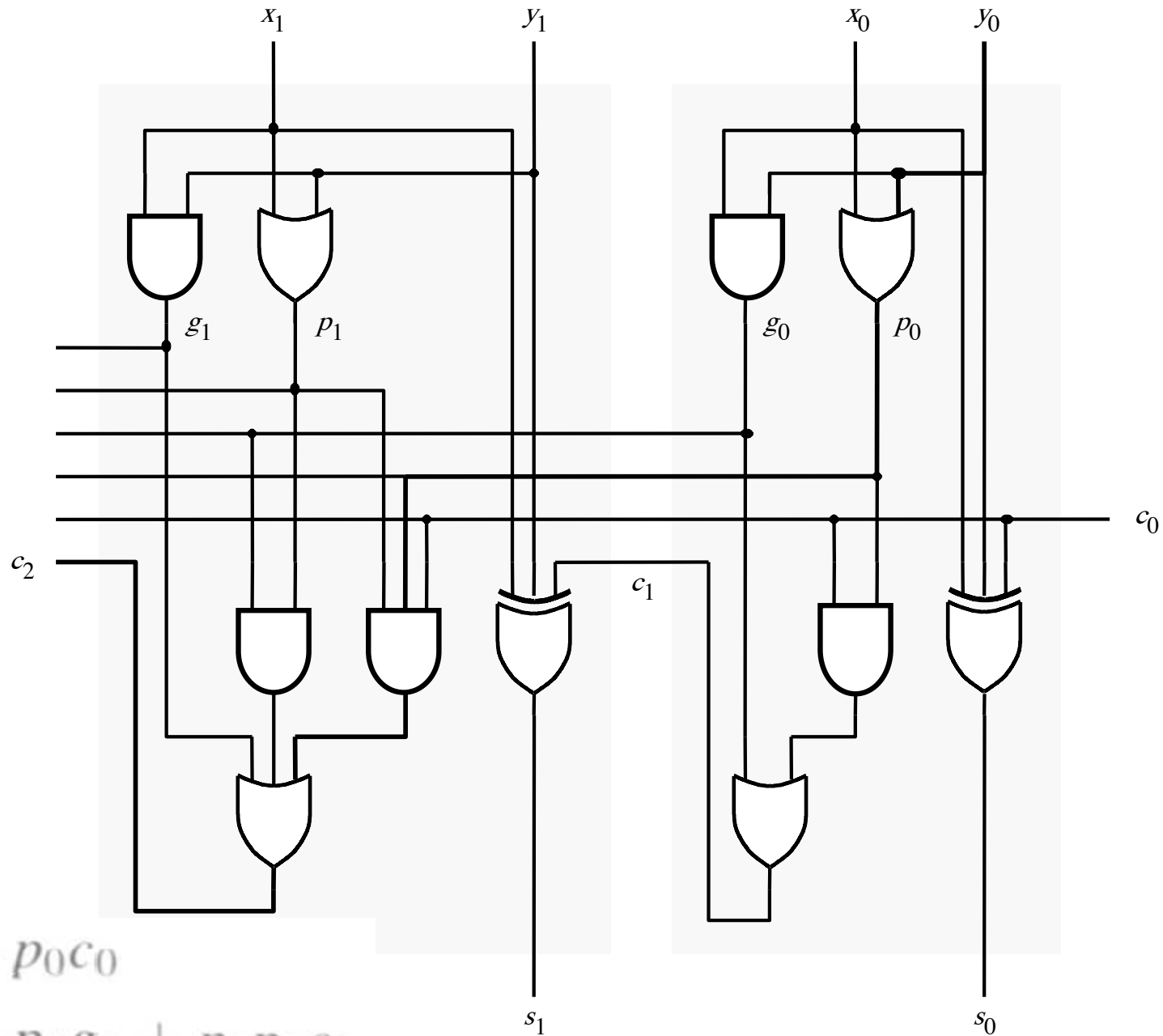

$$c_1 = g_0 + p_0 c_0$$

$$c_2 = g_1 + p_1 g_0 + p_1 p_0 c_0$$

[Figure 3.15 from the textbook]

It takes 3 gate delays to generate c_1

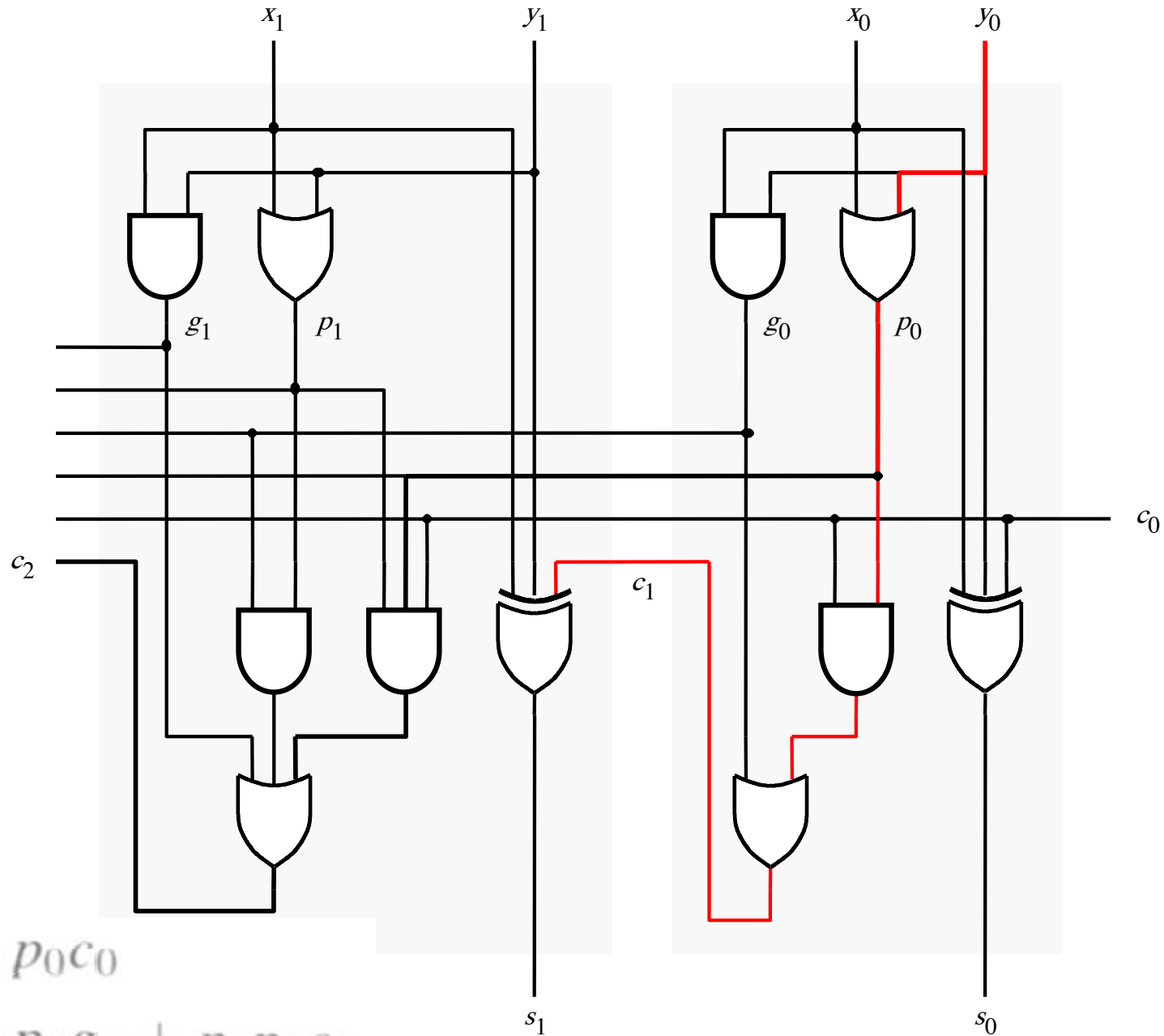

It takes 3 gate delays to generate c_2

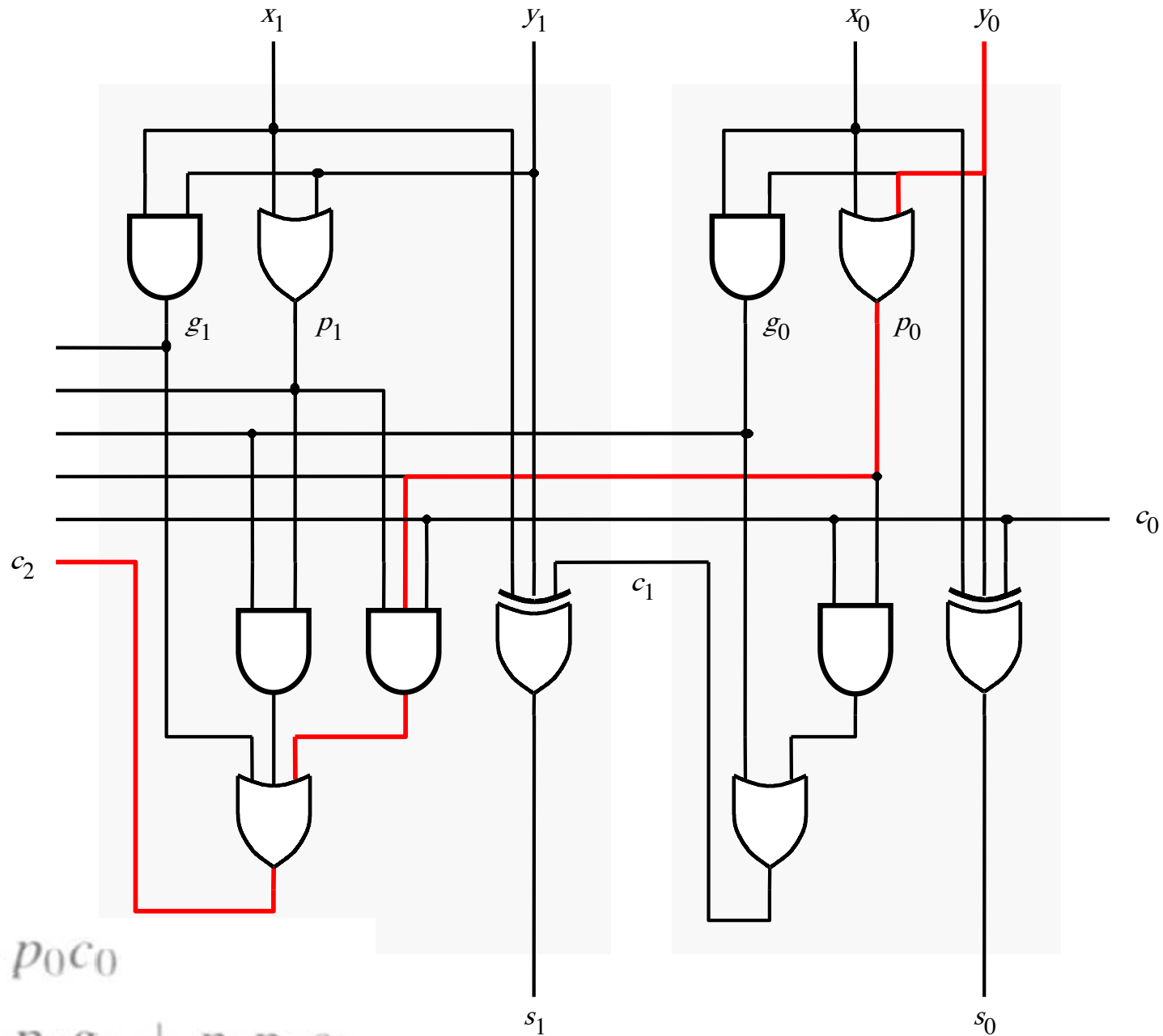

$$c_1 = g_0 + p_0 c_0$$

$$c_2 = g_1 + p_1 g_0 + p_1 p_0 c_0$$

The first two stages of a carry-lookahead adder

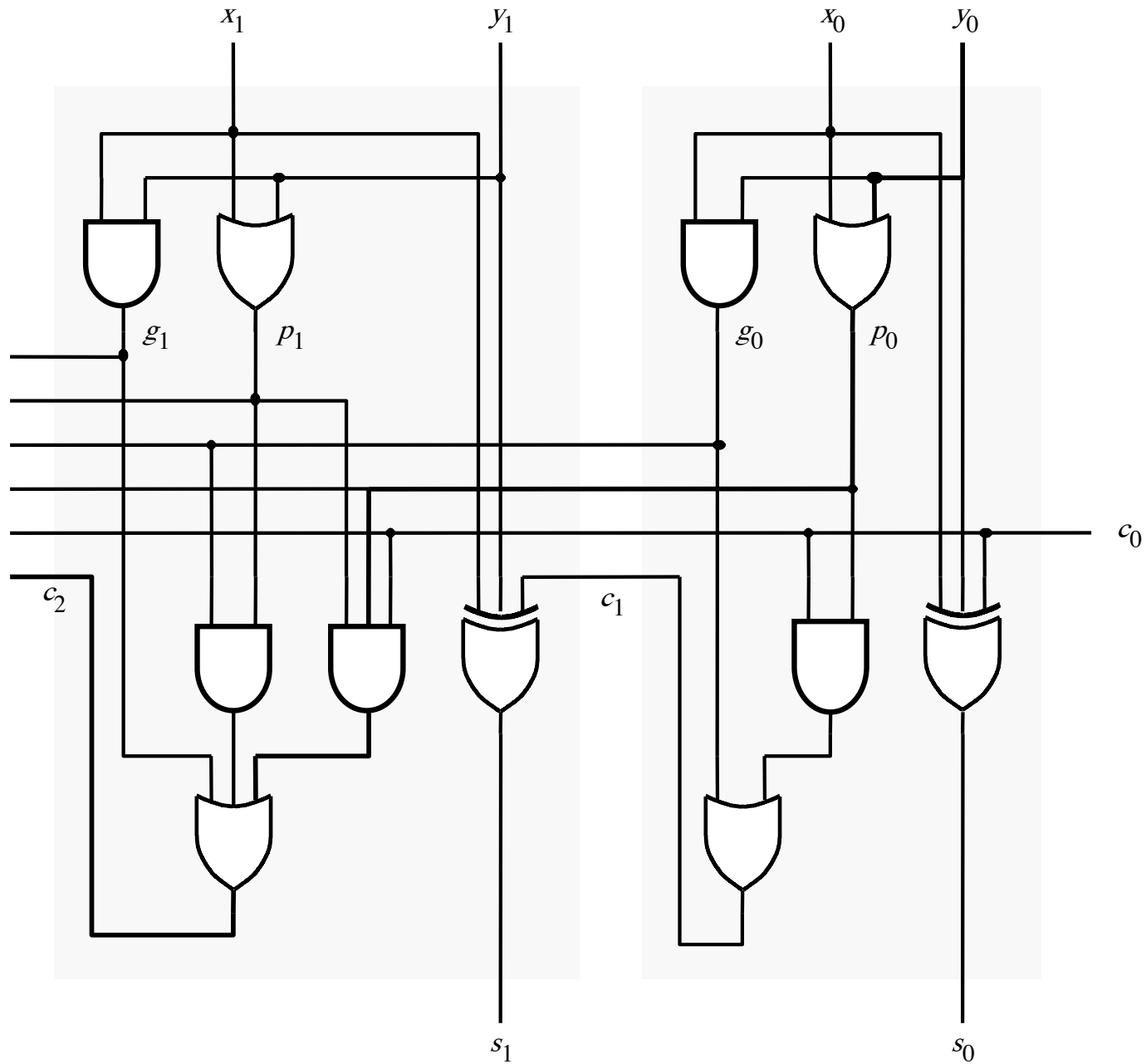

It takes 4 gate delays to generate s_1

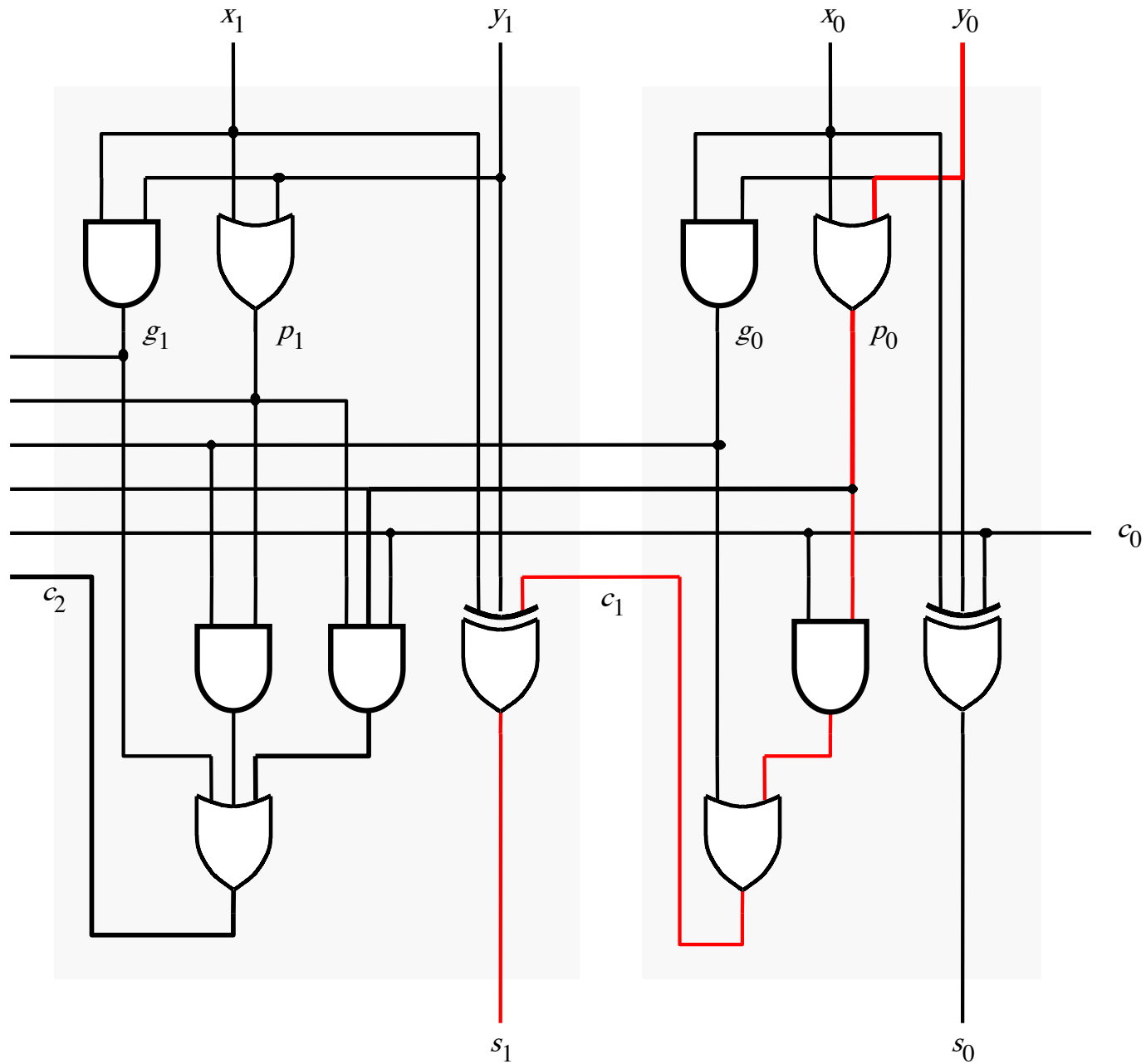

It takes 4 gate delays to generate s_2

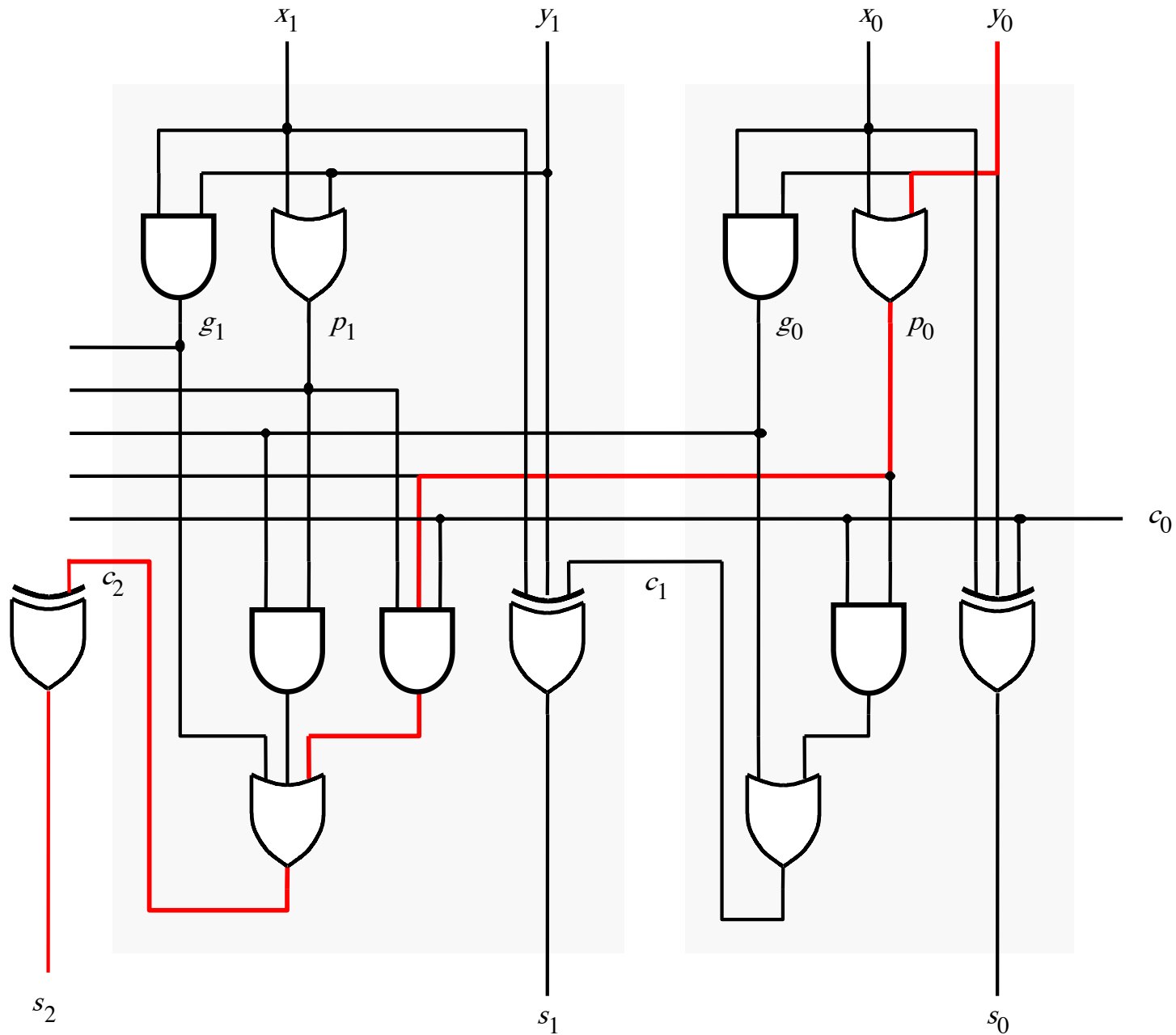

N-bit Carry-Lookahead Adder

- **It takes 3 gate delays to generate all carry signals**
- **It takes 1 more gate delay to generate all sum bits**
- **Thus, the total delay through an n-bit carry-lookahead adder is only 4 gate delays!**

Expanding the Carry Expression

$$c_{i+1} = g_i + p_i c_i$$

$$c_1 = g_0 + p_0 c_0$$

$$c_2 = g_1 + p_1 g_0 + p_1 p_0 c_0$$

$$c_3 = g_2 + p_2 g_1 + p_2 p_1 g_0 + p_2 p_1 p_0 c_0$$

...

$$\begin{aligned} c_8 = & g_7 + p_7 g_6 + p_7 p_6 g_5 + p_7 p_6 p_5 g_4 \\ & + p_7 p_6 p_5 p_4 g_3 + p_7 p_6 p_5 p_4 p_3 g_2 \\ & + p_7 p_6 p_5 p_4 p_3 p_2 g_1 + p_7 p_6 p_5 p_4 p_3 p_2 p_1 g_0 \\ & + p_7 p_6 p_5 p_4 p_3 p_2 p_1 p_0 c_0 \end{aligned}$$

Expanding the Carry Expression

$$c_{i+1} = g_i + p_i c_i$$

$$c_1 = g_0 + p_0 c_0$$

$$c_2 = g_1 + p_1 g_0 + p_1 p_0 c_0$$

$$c_3 = g_2 + p_2 g_1 + p_2 p_1 g_0 + p_2 p_1 p_0 c_0$$

...

$$c_8 = g_7 + p_7 g_6 + p_7 p_6 g_5 + p_7 p_6 p_5 g_4$$

Even this takes
only 3 gate delays

$$+ p_7 p_6 p_5 p_4 g_3 + p_7 p_6 p_5 p_4 p_3 g_2$$

$$+ p_7 p_6 p_5 p_4 p_3 p_2 g_1 + p_7 p_6 p_5 p_4 p_3 p_2 p_1 g_0$$

$$+ p_7 p_6 p_5 p_4 p_3 p_2 p_1 p_0 c_0$$

A hierarchical carry-lookahead adder with ripple-carry between blocks

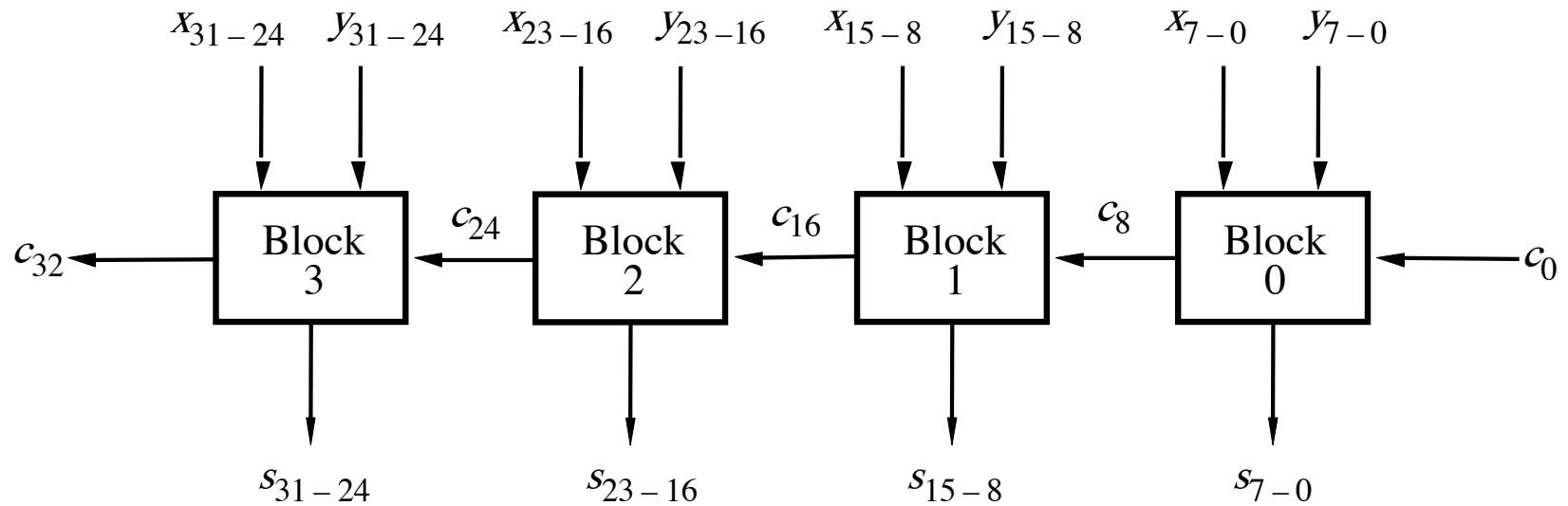

A hierarchical carry-lookahead adder with ripple-carry between blocks

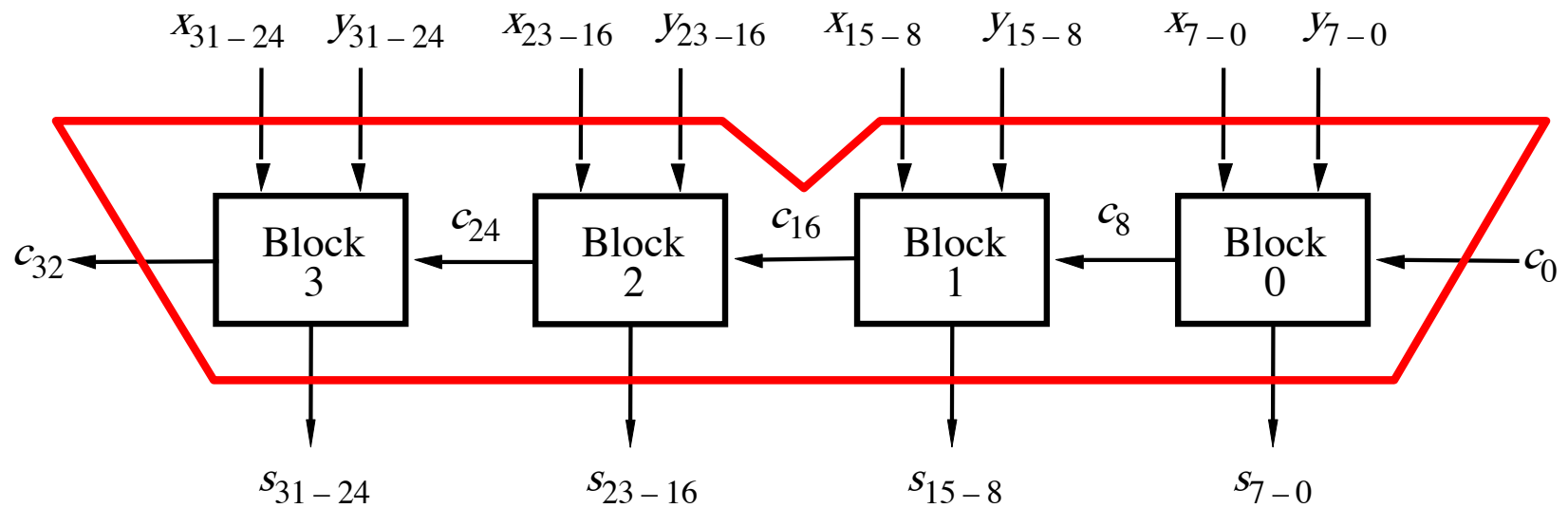

A hierarchical carry-lookahead adder with ripple-carry between blocks

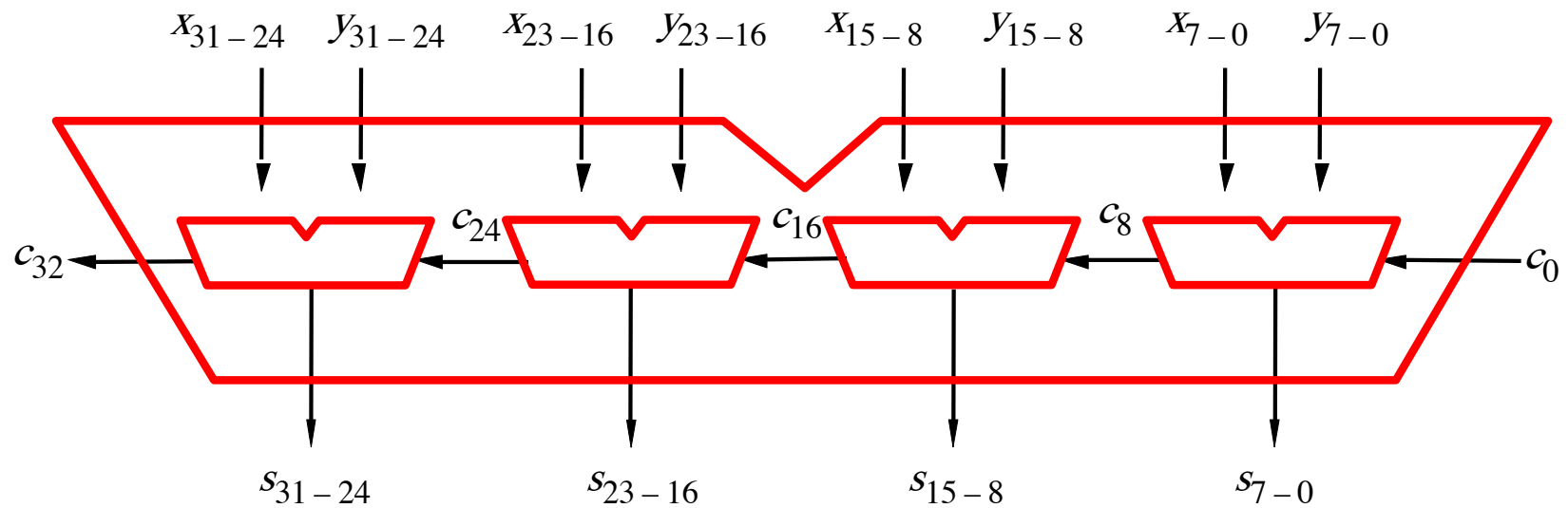

A hierarchical carry-lookahead adder with ripple-carry between blocks

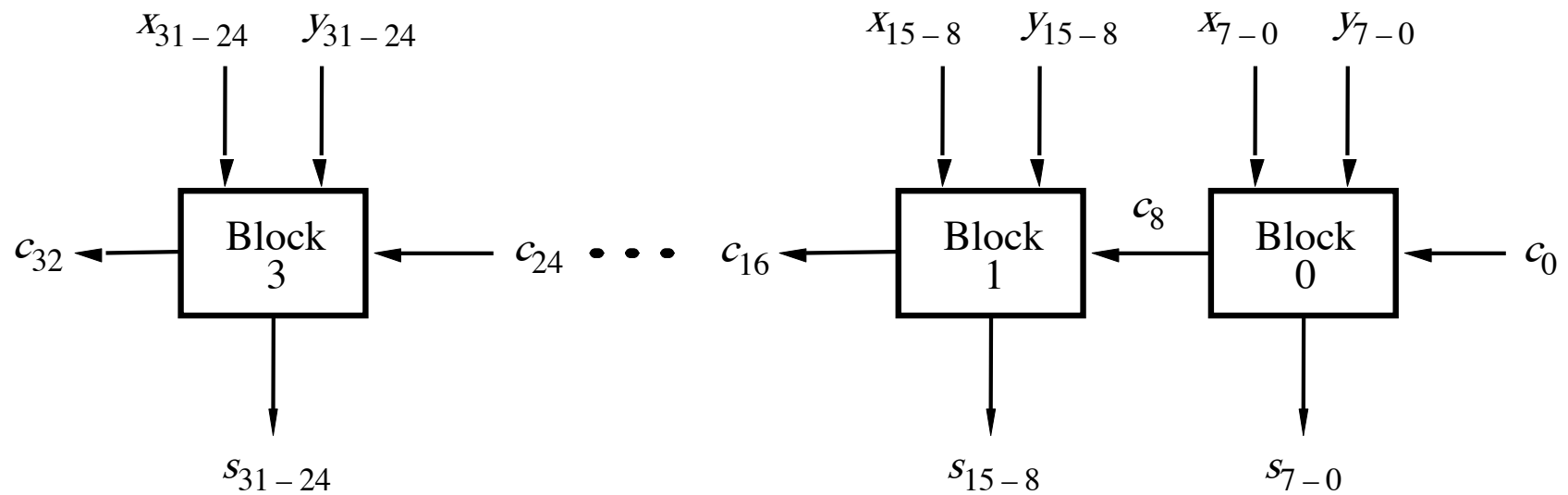

[Figure 3.16 from the textbook]

A hierarchical carry-lookahead adder

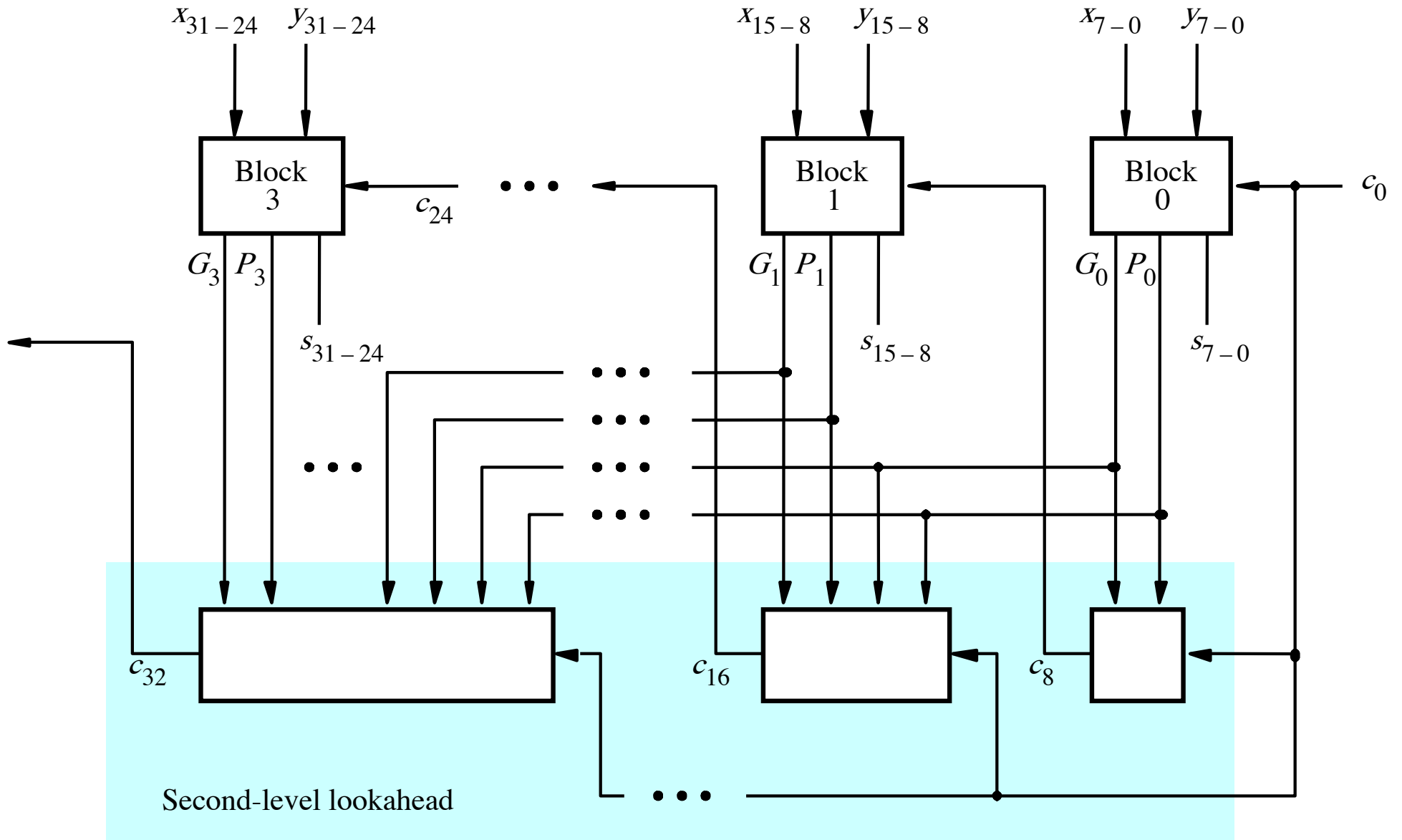

[Figure 3.17 from the textbook]

A hierarchical carry-lookahead adder

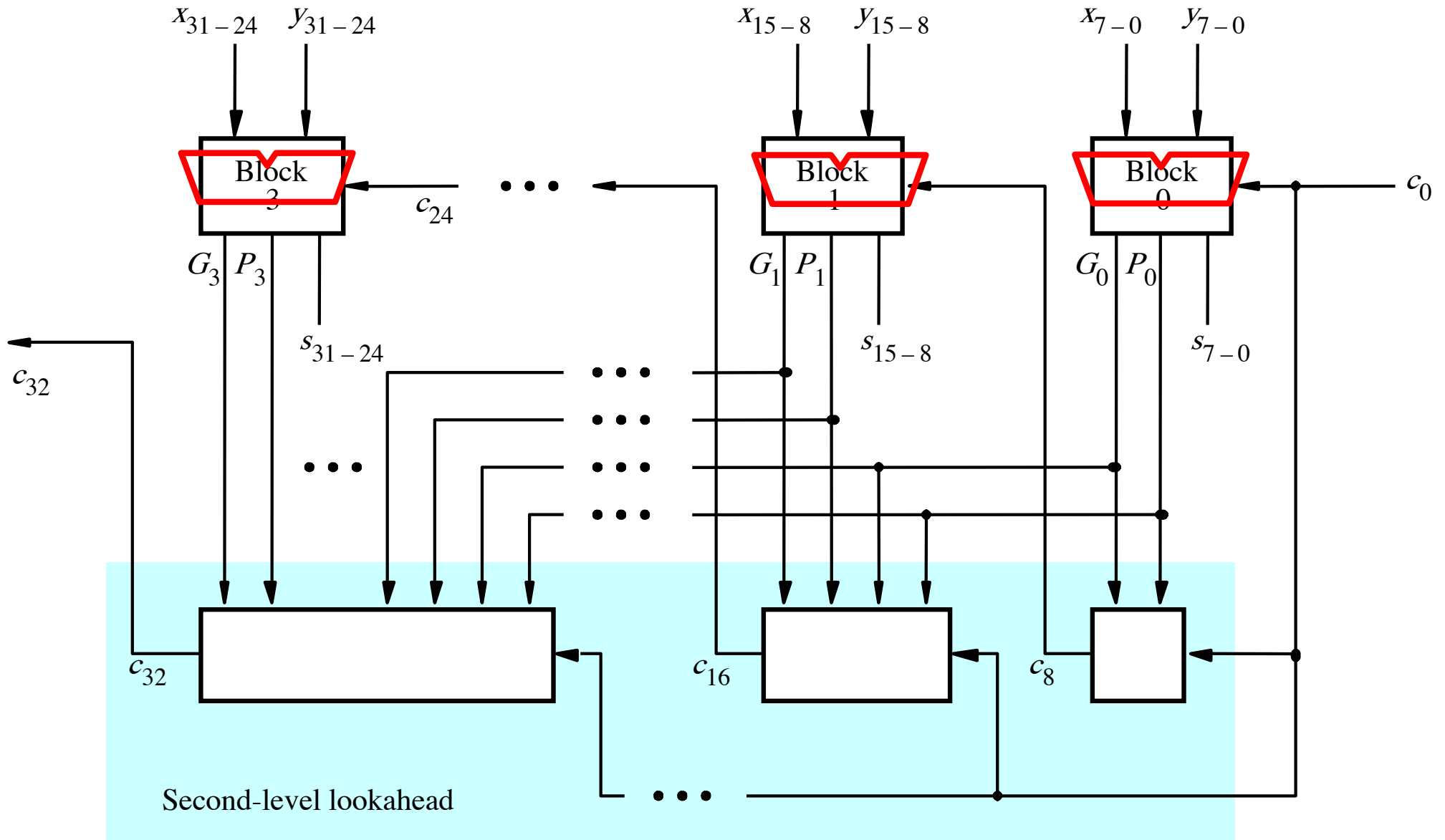

A hierarchical carry-lookahead adder

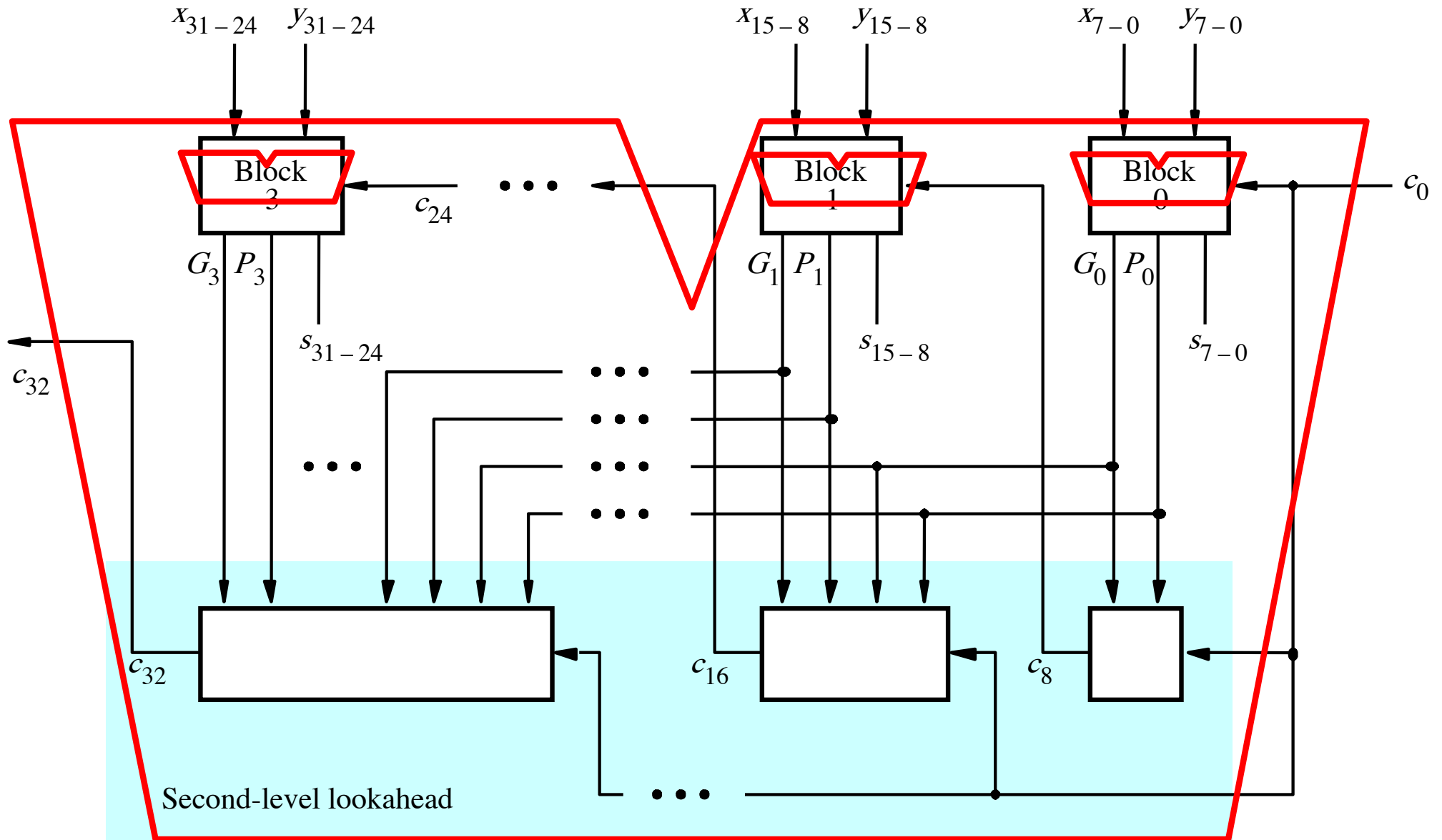

A hierarchical carry-lookahead adder

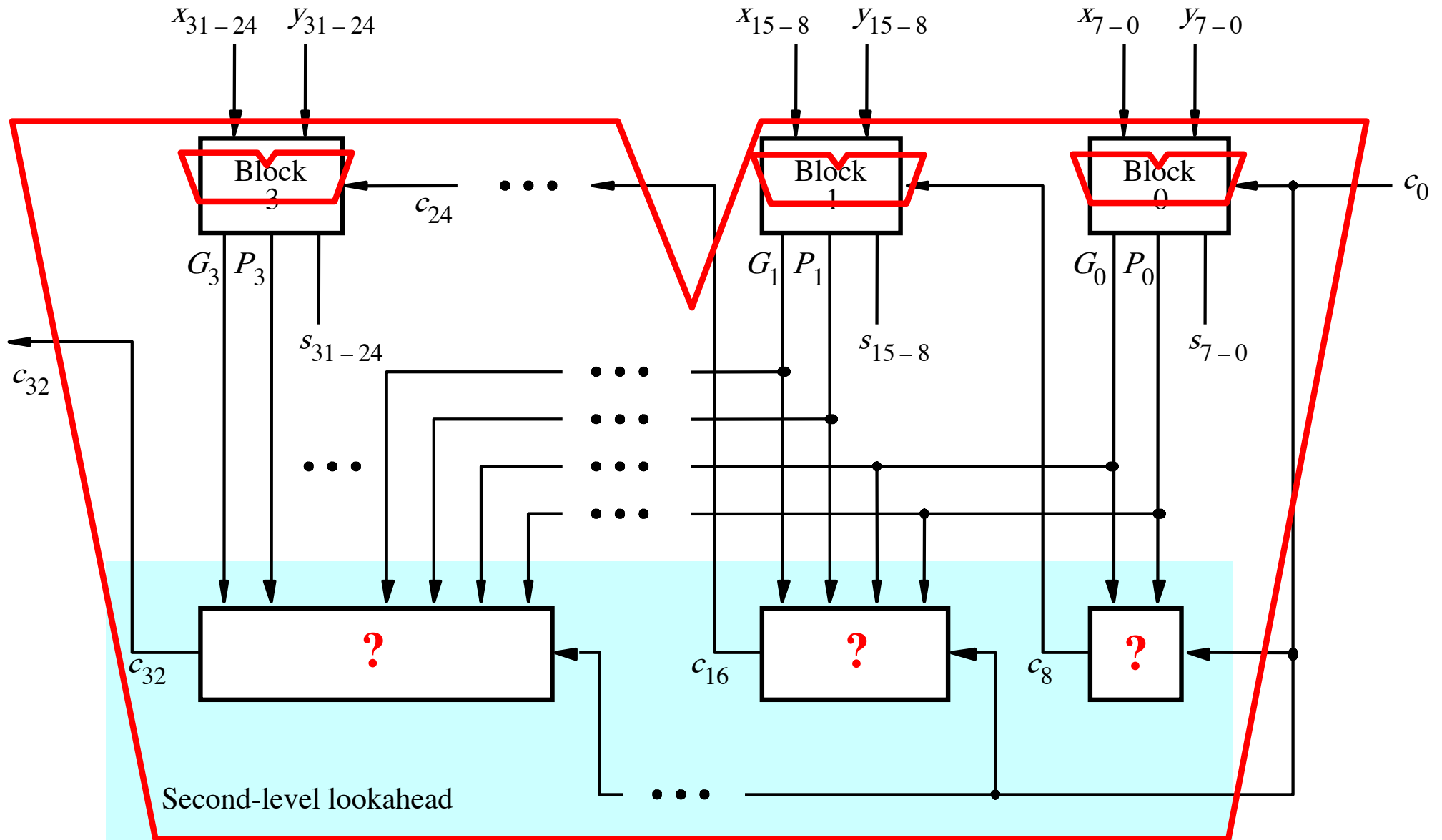

The Hierarchical Carry Expression

$$\begin{aligned}c_8 = & g_7 + p_7g_6 + p_7p_6g_5 + p_7p_6p_5g_4 \\ & + p_7p_6p_5p_4g_3 + p_7p_6p_5p_4p_3g_2 \\ & + p_7p_6p_5p_4p_3p_2g_1 + p_7p_6p_5p_4p_3p_2p_1g_0 \\ & + p_7p_6p_5p_4p_3p_2p_1p_0c_0\end{aligned}$$

The Hierarchical Carry Expression

$$\begin{aligned}c_8 = & g_7 + p_7g_6 + p_7p_6g_5 + p_7p_6p_5g_4 \\ & + p_7p_6p_5p_4g_3 + p_7p_6p_5p_4p_3g_2 \\ & + p_7p_6p_5p_4p_3p_2g_1 + p_7p_6p_5p_4p_3p_2p_1g_0 \\ & + p_7p_6p_5p_4p_3p_2p_1p_0c_0\end{aligned}$$

The Hierarchical Carry Expression

$$c_8 = g_7 + p_7g_6 + p_7p_6g_5 + p_7p_6p_5g_4$$
$$+ p_7p_6p_5p_4g_3 + p_7p_6p_5p_4p_3g_2$$
$$+ p_7p_6p_5p_4p_3p_2g_1 + p_7p_6p_5p_4p_3p_2p_1g_0$$
$$+ p_7p_6p_5p_4p_3p_2p_1p_0c_0$$

G_0 →

P_0 →

The Hierarchical Carry Expression

$$c_8 = g_7 + p_7g_6 + p_7p_6g_5 + p_7p_6p_5g_4 \\ + p_7p_6p_5p_4g_3 + p_7p_6p_5p_4p_3g_2 \\ + p_7p_6p_5p_4p_3p_2g_1 + p_7p_6p_5p_4p_3p_2p_1g_0 \\ + p_7p_6p_5p_4p_3p_2p_1p_0c_0$$

G_0 →

P_0 →

$$c_8 = G_0 + P_0c_0$$

The Hierarchical Carry Expression

$$c_8 = G_0 + P_0 c_0$$

$$\begin{aligned} c_{16} &= G_1 + P_1 c_8 \\ &= G_1 + P_1 G_0 + P_1 P_0 c_0 \end{aligned}$$

$$c_{24} = G_2 + P_2 G_1 + P_2 P_1 G_0 + P_2 P_1 P_0 c_0$$

$$c_{32} = G_3 + P_3 G_2 + P_3 P_2 G_1 + P_3 P_2 P_1 G_0 + P_3 P_2 P_1 P_0 c_0$$

A hierarchical carry-lookahead adder

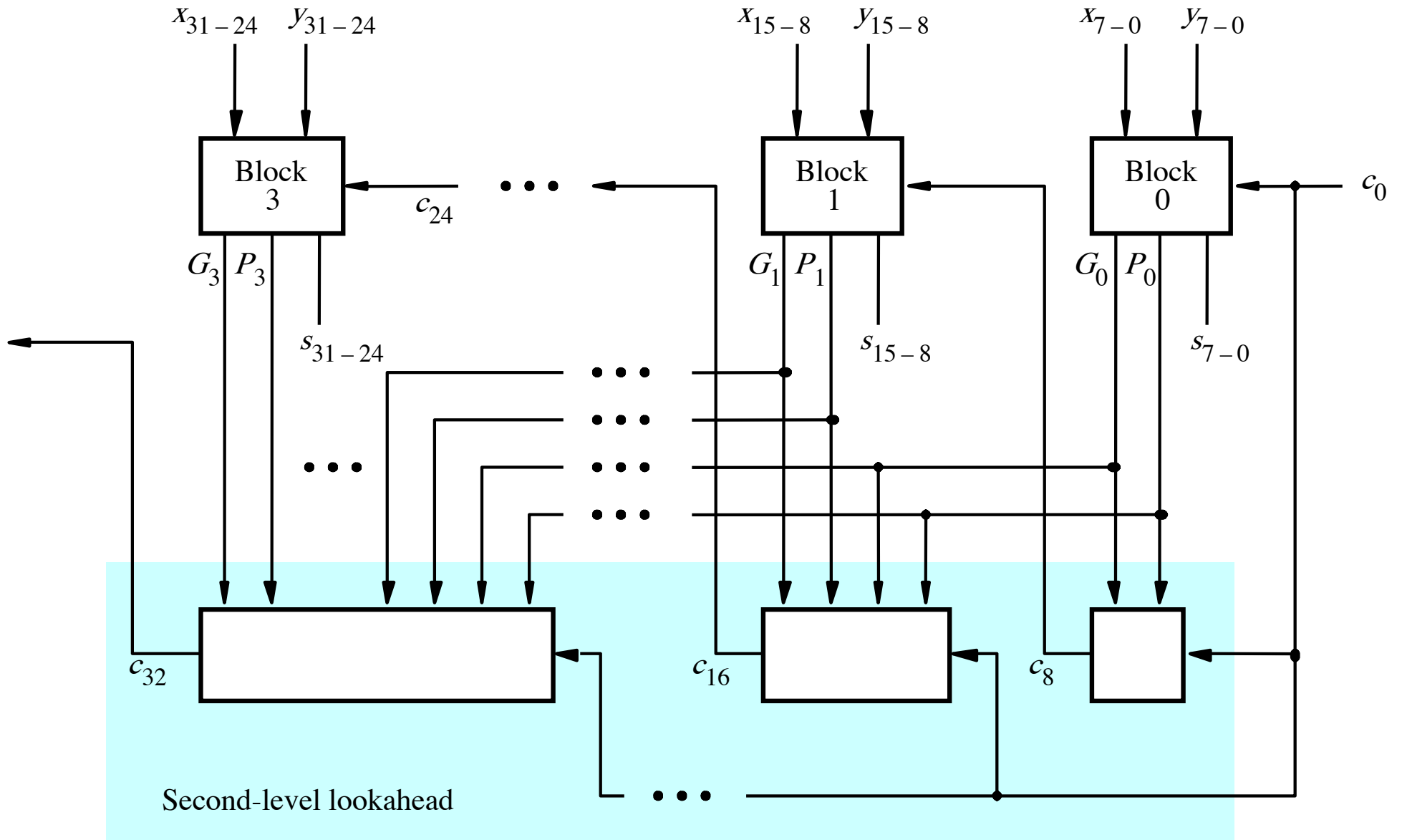

[Figure 3.17 from the textbook]

A hierarchical carry-lookahead adder

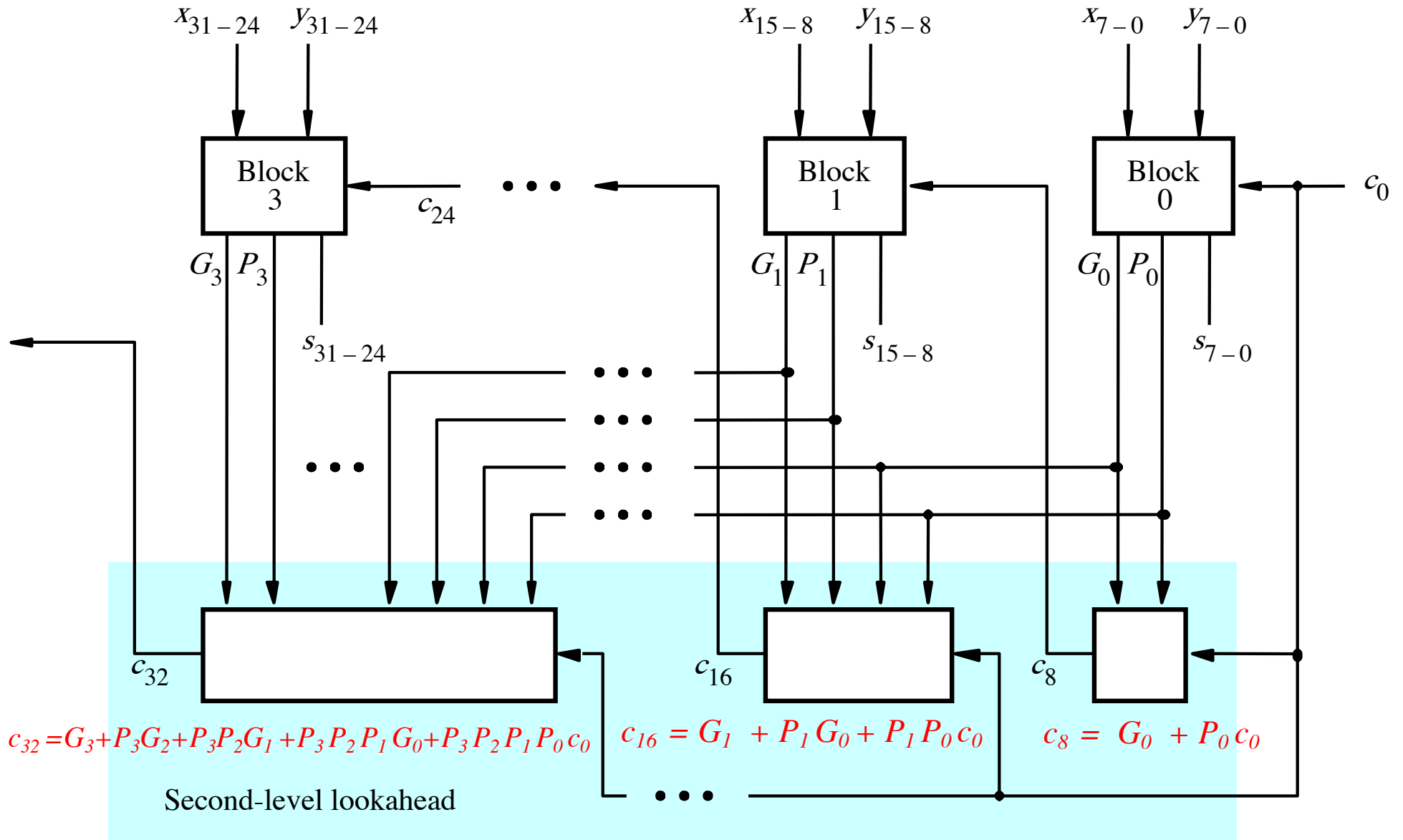

[Figure 3.17 from the textbook]

Hierarchical CLA Adder Carry Logic

SECOND
LEVEL
HIERARCHY

- C8 – 5 gate delays
- C16 – 5 gate delays
- C24 – 5 Gate delays
- C32 – 5 Gate delays

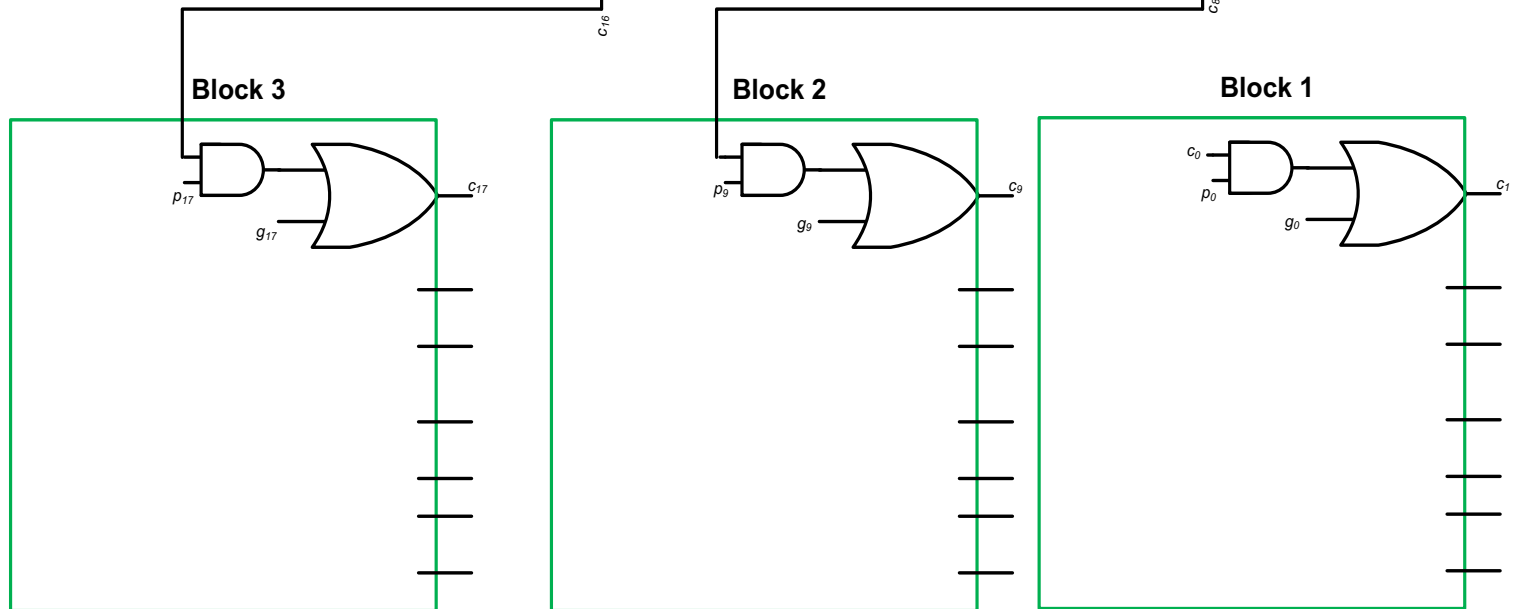
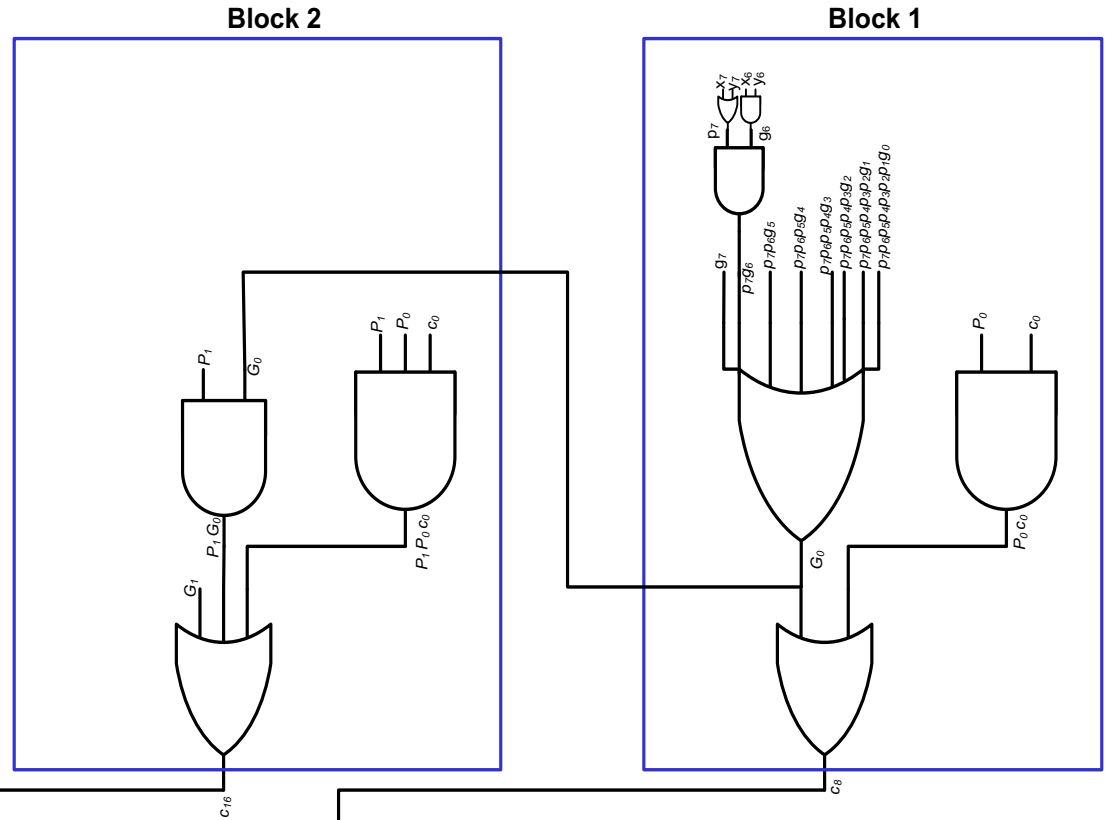

FIRST LEVEL HIERARCHY

Hierarchical CLA Critical Path

SECOND
LEVEL
HIERARCHY

- C9** – 7 gate delays
- C17** – 7 gate delays
- C25** – 7 Gate delays

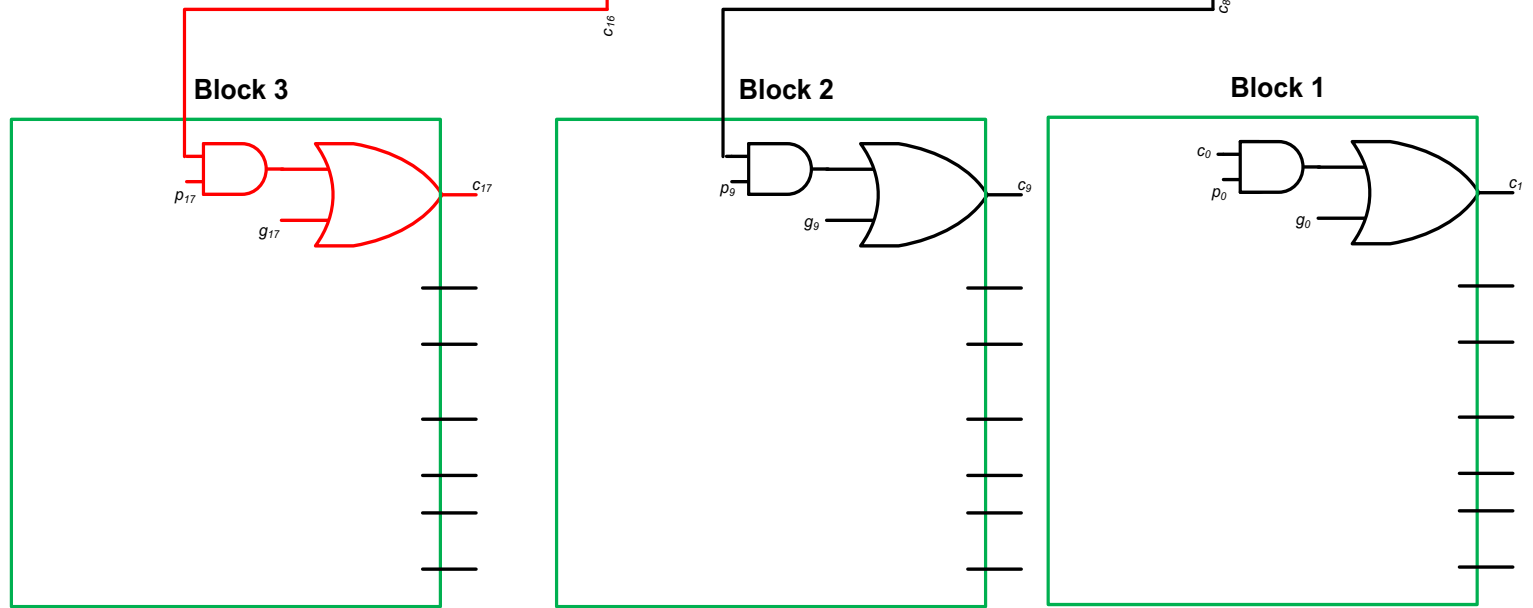
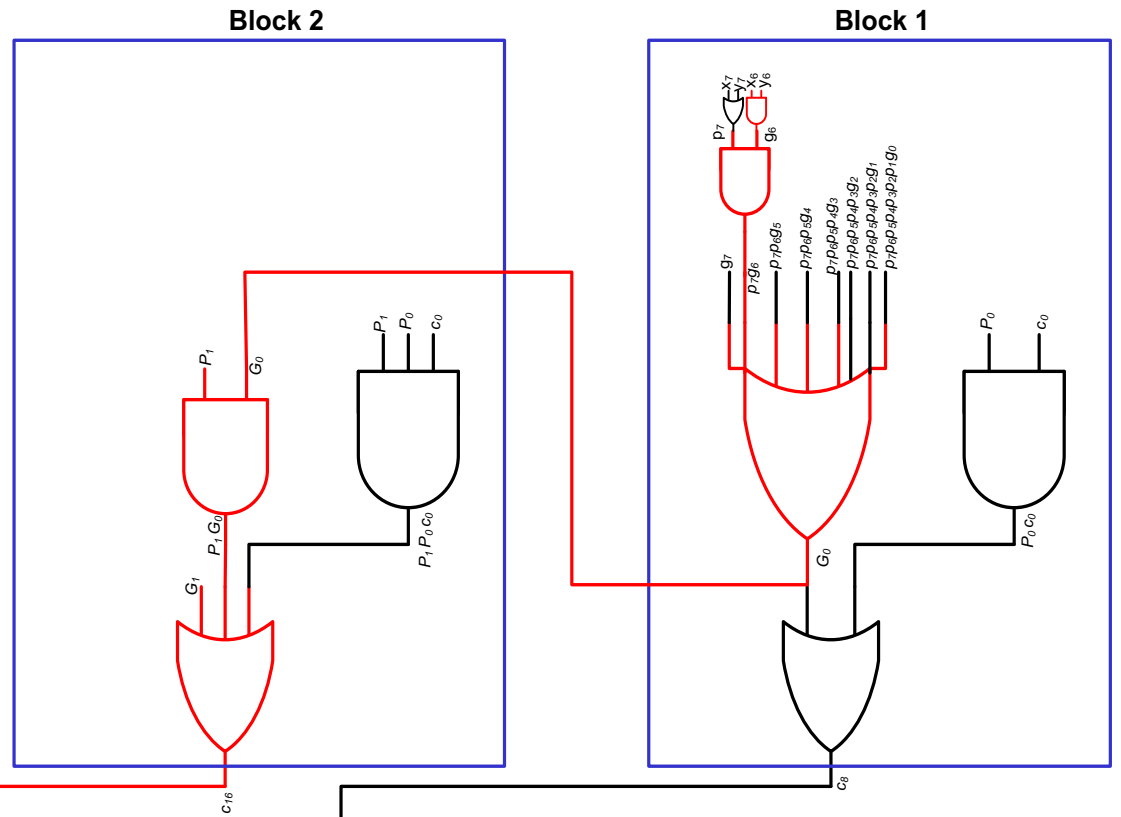

FIRST LEVEL HIERARCHY

Total Gate Delay Through a Hierarchical Carry-Lookahead Adder

- Is 8 gates
 - 3 to generate all G_j and P_j
 - +2 to generate c_8 , c_{16} , c_{24} , and c_{32}
 - +2 to generate internal carries in the blocks
 - +1 to generate the sum bits (one extra XOR)

Decimal Multiplication by 10

What happens when we multiply a number by 10?

$$4 \times 10 = ?$$

$$542 \times 10 = ?$$

$$1245 \times 10 = ?$$

Decimal Multiplication by 10

What happens when we multiply a number by 10?

$$4 \times 10 = 40$$

$$542 \times 10 = 5420$$

$$1245 \times 10 = 12450$$

Decimal Multiplication by 10

What happens when we multiply a number by 10?

$$4 \times 10 = 40$$

$$542 \times 10 = 5420$$

$$1245 \times 10 = 12450$$

You simply add a zero as the rightmost number

Decimal Division by 10

What happens when we divide a number by 10?

$$14 / 10 = ?$$

$$540 / 10 = ?$$

$$1240 / 10 = ?$$

Decimal Division by 10

What happens when we divide a number by 10?

$$14 / 10 = 1 \quad //\text{integer division}$$

$$540 / 10 = 54$$

$$1240 / 10 = 124$$

You simply delete the rightmost number

Binary Multiplication by 2

What happens when we multiply a number by 2?

011 times 2 = ?

101 times 2 = ?

110011 times 2 = ?

Binary Multiplication by 2

What happens when we multiply a number by 2?

$$011 \text{ times } 2 = 0110$$

$$101 \text{ times } 2 = 1010$$

$$110011 \text{ times } 2 = 1100110$$

You simply add a zero as the rightmost number

Binary Multiplication by 4

What happens when we multiply a number by 4?

011 times 4 = ?

101 times 4 = ?

110011 times 4 = ?

Binary Multiplication by 4

What happens when we multiply a number by 4?

$$011 \text{ times } 4 = 01100$$

$$101 \text{ times } 4 = 10100$$

$$110011 \text{ times } 4 = 11001100$$

add two zeros in the last two bits and shift everything else to the left

Binary Multiplication by 2^N

What happens when we multiply a number by 2^N ?

011 times $2^N = 01100\dots0$ // add N zeros

101 times 4 = 10100...0 // add N zeros

110011 times 4 = 11001100...0 // add N zeros

Binary Division by 2

What happens when we divide a number by 2?

0110 divided by 2 = ?

1010 divides by 2 = ?

110011 divides by 2 = ?

Binary Division by 2

What happens when we divide a number by 2?

0110 divided by 2 = 011

1010 divides by 2 = 101

110011 divides by 2 = 11001

You simply delete the rightmost number

Decimal Multiplication By Hand

$$\begin{array}{r} 5127 \\ \times 4265 \\ \hline 25635 \\ 307620 \\ 1025400 \\ 20508000 \\ \hline 21866655 \end{array}$$

Binary Multiplication By Hand

Multiplicand M	(14)	1 1 1 0
Multiplier Q	(11)	x 1 0 1 1
		<hr/>
		1 1 1 0
		1 1 1 0
		0 0 0 0
		1 1 1 0
		<hr/>
Product P	(154)	1 0 0 1 1 0 1 0

Binary Multiplication By Hand

Multiplicand M	(14)	1 1 1 0
Multiplier Q	(11)	× 1 0 1 1
		<hr/>
Partial product 0		1 1 1 0
		+ 1 1 1 0
		<hr/>
Partial product 1		1 0 1 0 1
		+ 0 0 0 0
		<hr/>
Partial product 2		0 1 0 1 0
		+ 1 1 1 0
		<hr/>
Product P	(154)	1 0 0 1 1 0 1 0

[Figure 3.34b from the textbook]

Binary Multiplication By Hand

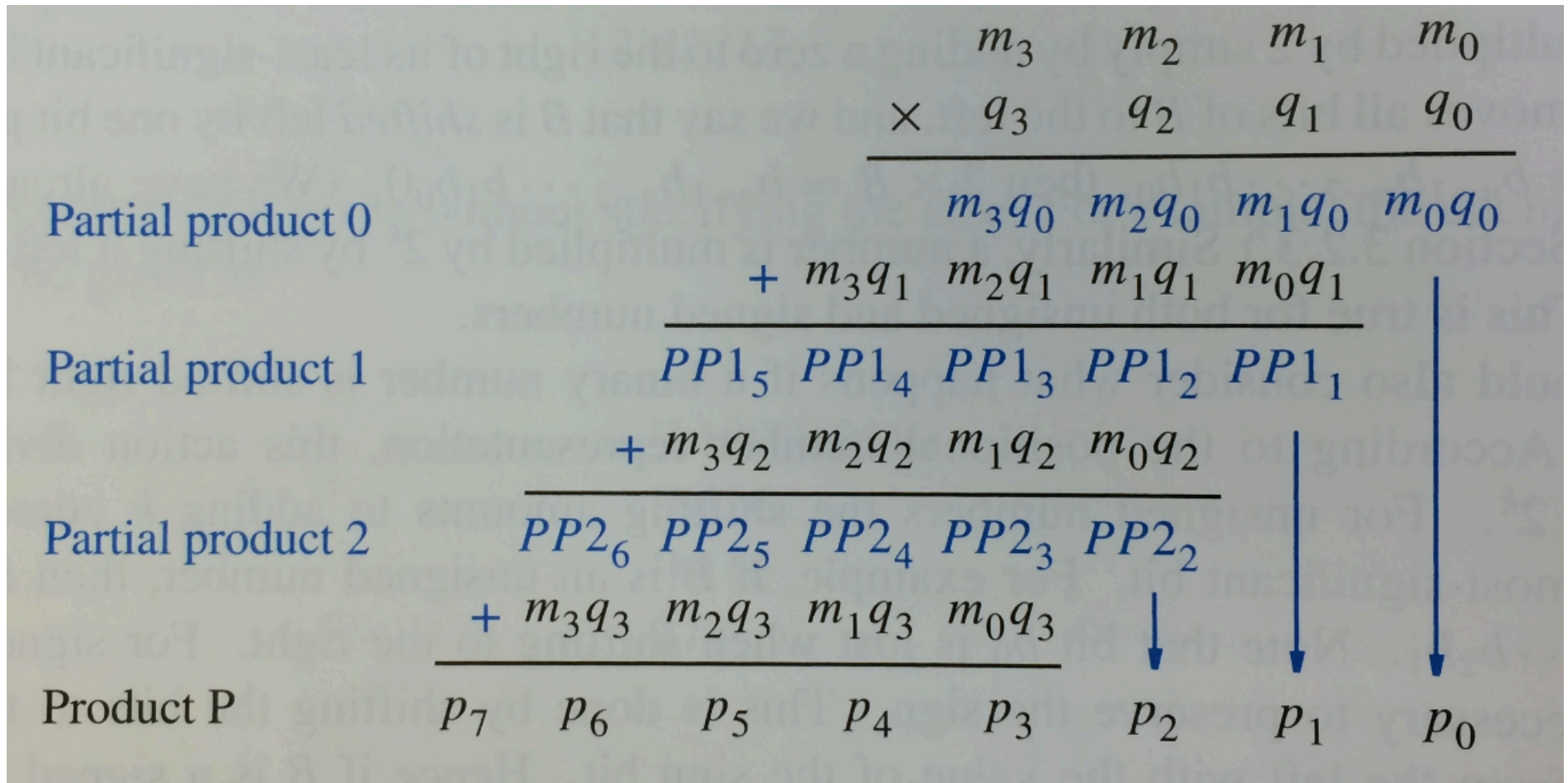

[Figure 3.34c from the textbook]

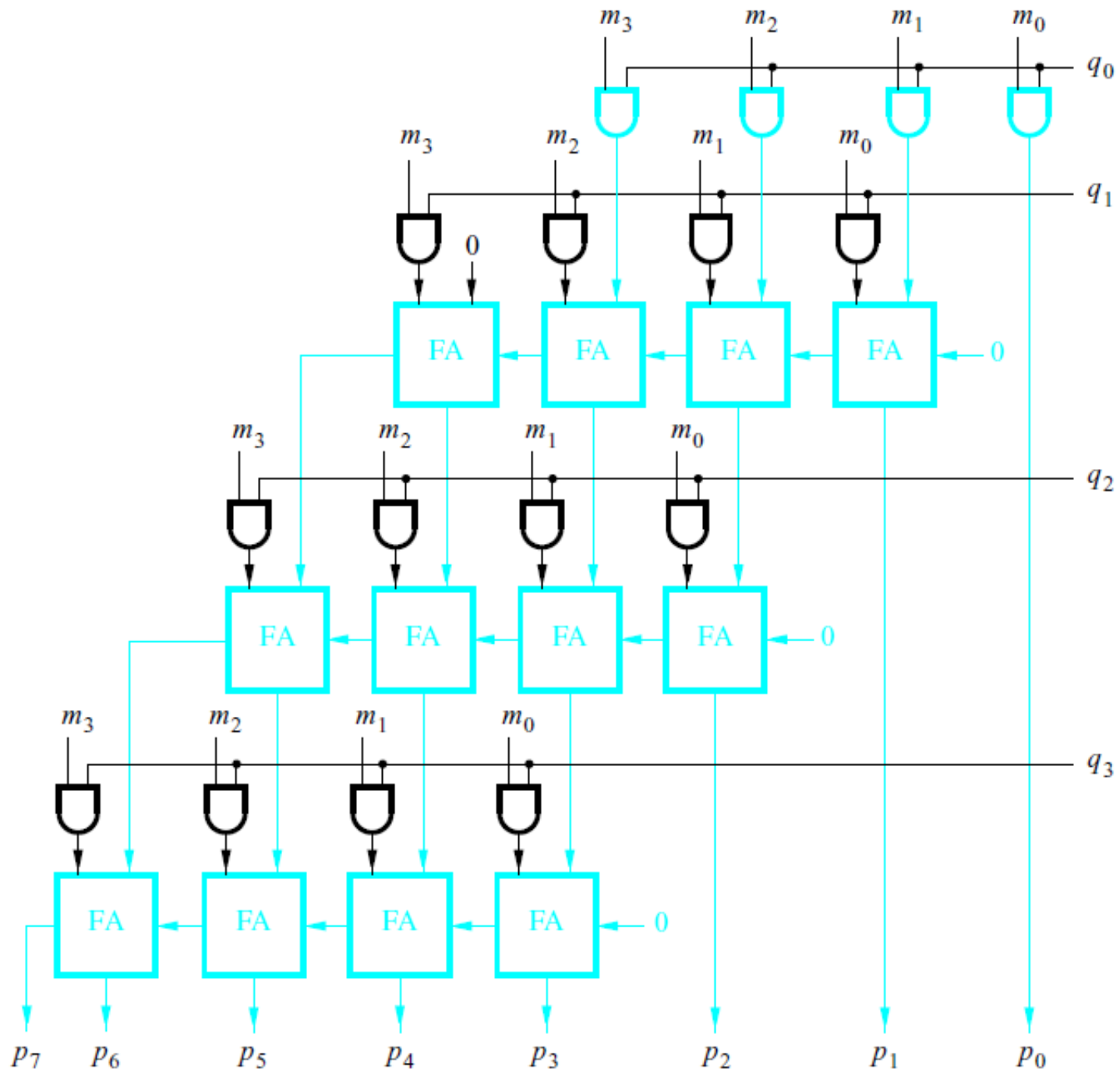

Figure 3.35. A 4x4 multiplier circuit.

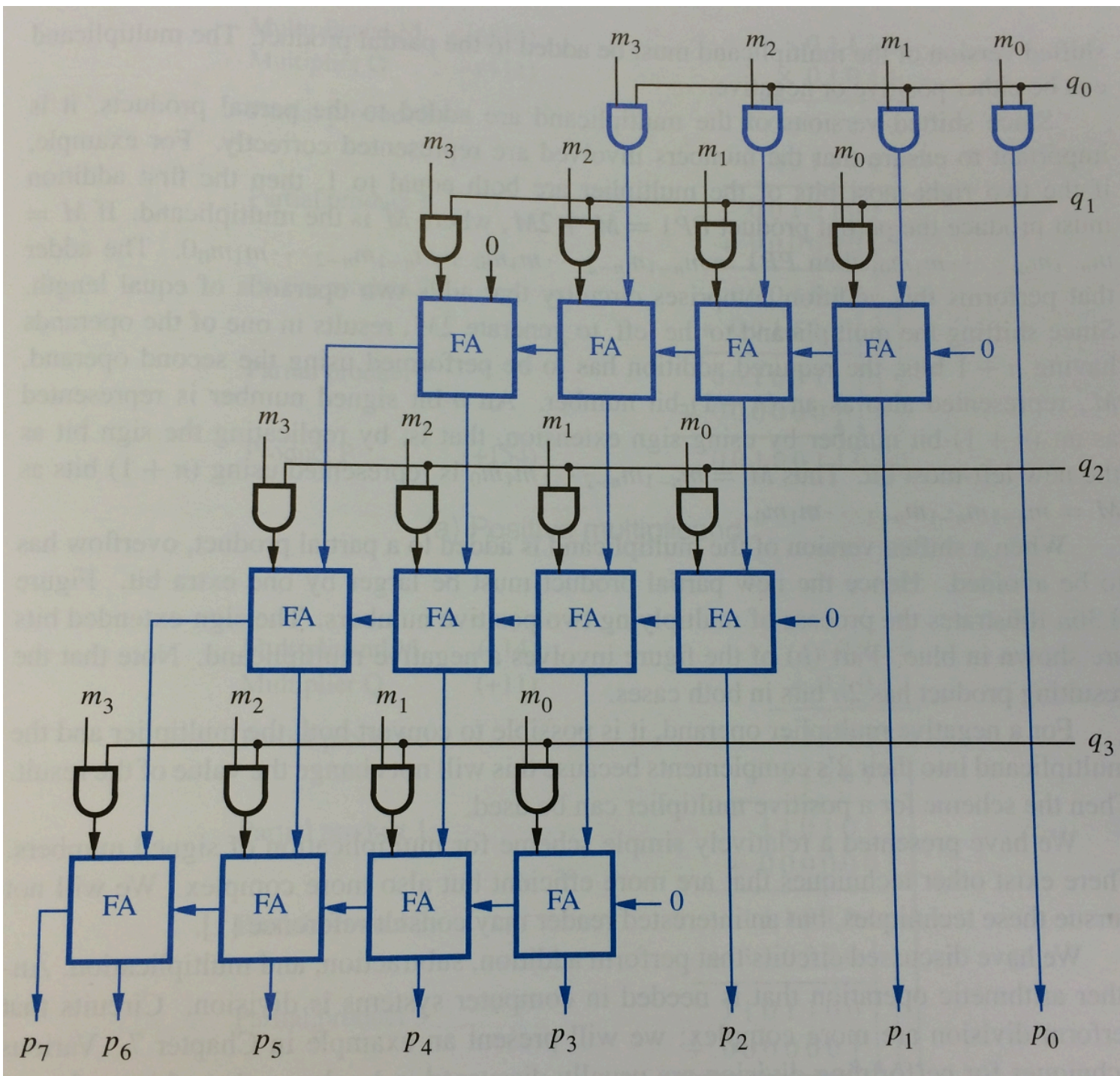

Figure 3.35. A 4x4 multiplier circuit.

Positive Multiplicand Example

Multiplicand M	(+14)		0	1	1	1	0
Multiplier Q	(+11)		x	0	1	0	1
Partial product 0			0	0	0	1	1
			+	0	0	1	1
Partial product 1			0	0	1	0	1
			+	0	0	0	0
Partial product 2			0	0	0	1	0
			+	0	0	1	1
Partial product 3			0	0	1	0	0
			+	0	0	0	0
Product P	(+154)		0	0	1	0	0
			0	1	1	0	1

[Figure 3.36a in the textbook]

Positive Multiplicand Example

Multiplicand M	(+14)		0 1 1 1 0
Multiplier Q	(+11)		x 0 1 0 1 1
Partial product 0			0 0 0 1 1 1 0
		add an extra bit to avoid overflow	+ 0 0 1 1 1 0
Partial product 1			0 0 1 0 1 0 1
			+ 0 0 0 0 0 0
Partial product 2			0 0 0 1 0 1 0
			+ 0 0 1 1 1 0
Partial product 3			0 0 1 0 0 1 1
			+ 0 0 0 0 0 0
Product P	(+154)		0 0 1 0 0 1 1 0 1 0

[Figure 3.36a in the textbook]

Negative Multiplicand Example

Multiplicand M (-14)

Multiplier Q (+11)

Partial product 0

Partial product 1

Partial product 2

Partial product 3

Product P (-154)

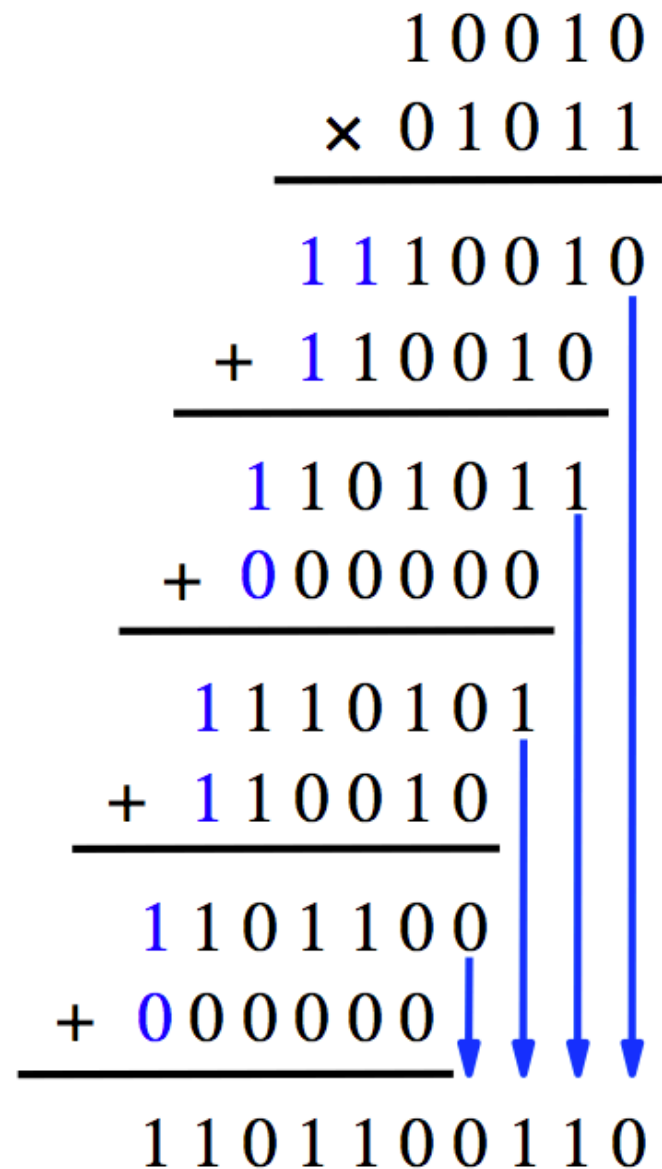

[Figure 3.36b in the textbook]

Negative Multiplicand Example

Multiplicand M	(-14)		1 0 0 1 0
Multiplier Q	(+11)		× 0 1 0 1 1
Partial product 0		add an extra bit to avoid overflow but now it is 1	$\begin{array}{r} 1110010 \\ + 110010 \\ \hline \end{array}$
Partial product 1			$\begin{array}{r} 1101011 \\ + 000000 \\ \hline \end{array}$
Partial product 2			$\begin{array}{r} 1110101 \\ + 110010 \\ \hline \end{array}$
Partial product 3			$\begin{array}{r} 1101100 \\ + 000000 \\ \hline \end{array}$
Product P	(-154)		1 1 0 1 1 0 0 1 1 0

[Figure 3.36b in the textbook]

What if the Multiplier is Negative?

- Convert both to their 2's complement version
- This will make the multiplier positive
- Then Proceed as normal
- This will not affect the result
- Example: $5*(-4) = (-5)*(4) = -20$

Binary Coded Decimal

Table of Binary-Coded Decimal Digits

Decimal digit	BCD code
0	0000
1	0001
2	0010
3	0011
4	0100
5	0101
6	0110
7	0111
8	1000
9	1001

Addition of BCD digits

$$\begin{array}{r} X \\ + Y \\ \hline Z \end{array} \qquad \begin{array}{r} 0111 \\ + 0101 \\ \hline 1100 \end{array} \qquad \begin{array}{r} 7 \\ + 5 \\ \hline 12 \end{array}$$

Addition of BCD digits

$$\begin{array}{r} X \\ + Y \\ \hline Z \end{array} \quad \begin{array}{r} 0111 \\ + 0101 \\ \hline 1100 \end{array} \quad \begin{array}{r} 7 \\ + 5 \\ \hline 12 \end{array}$$

The result is greater than 9, which is not a valid BCD number

Addition of BCD digits

X	0 1 1 1	7
+ Y	+ 0 1 0 1	+ 5
<hr/>		
Z	1 1 0 0	12
	+ 0 1 1 0	
	<hr/>	
carry →	1 0 0 1 0	
	$\underbrace{\hspace{2cm}}$	
	S = 2	

← add 6

Addition of BCD digits

X	1 0 0 0	8
+ Y	+ 1 0 0 1	+ 9
<hr/>	<hr/>	<hr/>
Z	1 0 0 0 1	17

Addition of BCD digits

X	1 0 0 0	8
+ Y	+ 1 0 0 1	+ 9
<hr/>	<hr/>	<hr/>
Z	1 0 0 0 1	17



The result is 1, but it should be 7

Addition of BCD digits

X	1 0 0 0	8
+ Y	+ 1 0 0 1	+ 9
<hr/>		
Z	1 0 0 0 1	17
	+ 0 1 1 0	
	<hr/>	
carry →	1 0 1 1 1	
	$\underbrace{\hspace{2em}}$	
	S = 7	

← add 6

Why add 6?

- **Think of BCD addition as a mod 16 operation**
- **Decimal addition is mod 10 operation**

BCD Arithmetic Rules

$$Z = X + Y$$

If $Z \leq 9$, then $S=Z$ and carry-out = 0

If $Z > 9$, then $S=Z+6$ and carry-out = 1

Block diagram for a one-digit BCD adder

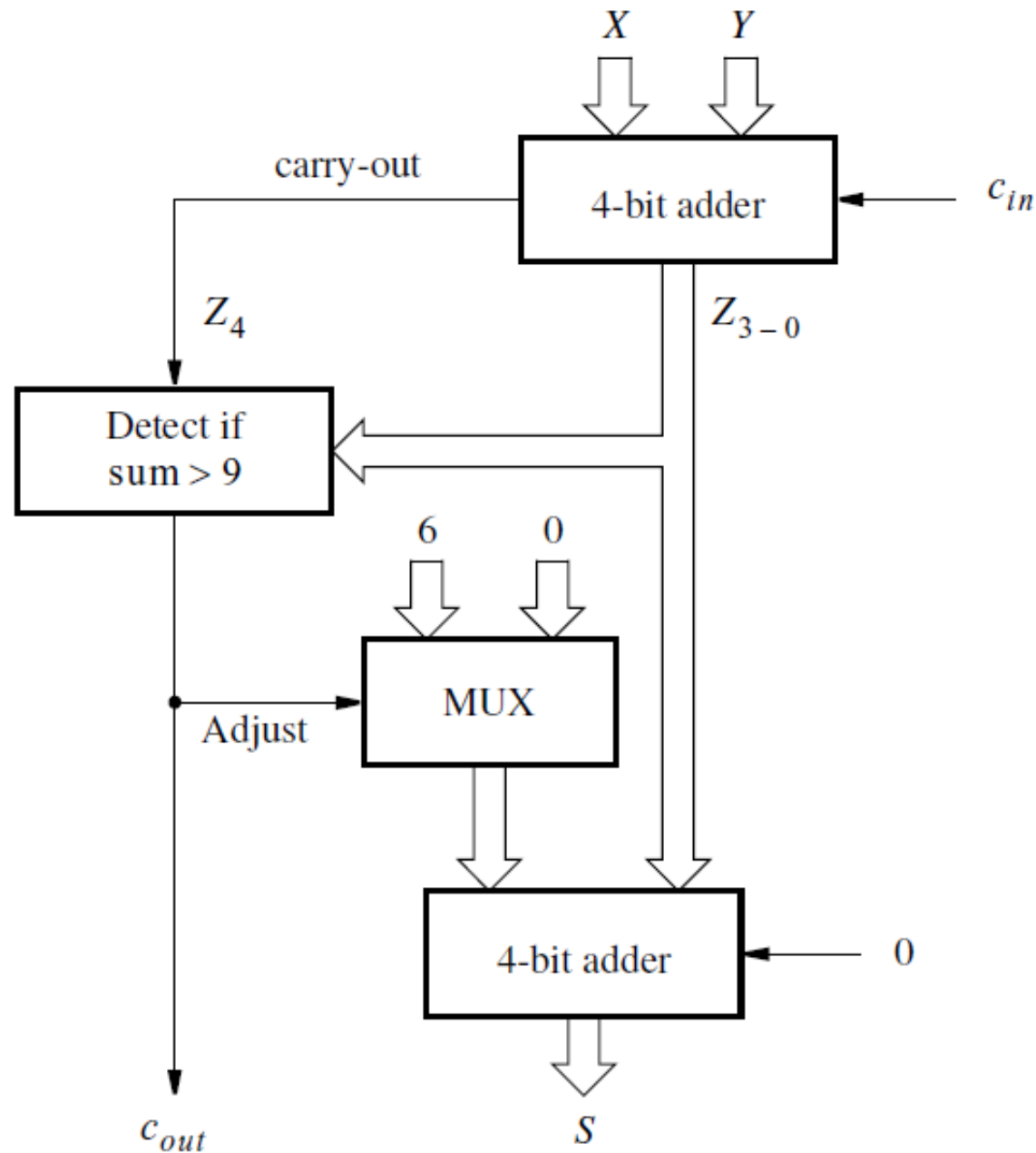

[Figure 3.39 in the textbook]

How to check if the number is > 9 ?

7 - 0111

8 - 1000

9 - 1001

10 - 1010

11 - 1011

12 - 1100

13 - 1101

14 - 1110

15 - 1111

A four-variable Karnaugh map

x1	x2	x3	x4	
0	0	0	0	m0
0	0	0	1	m1
0	0	1	0	m2
0	0	1	1	m3
<hr/>				
0	1	0	0	m4
0	1	0	1	m5
0	1	1	0	m6
0	1	1	1	m7
<hr/>				
1	0	0	0	m8
1	0	0	1	m9
1	0	1	0	m10
1	0	1	1	m11
<hr/>				
1	1	0	0	m12
1	1	0	1	m13
1	1	1	0	m14
1	1	1	1	m15

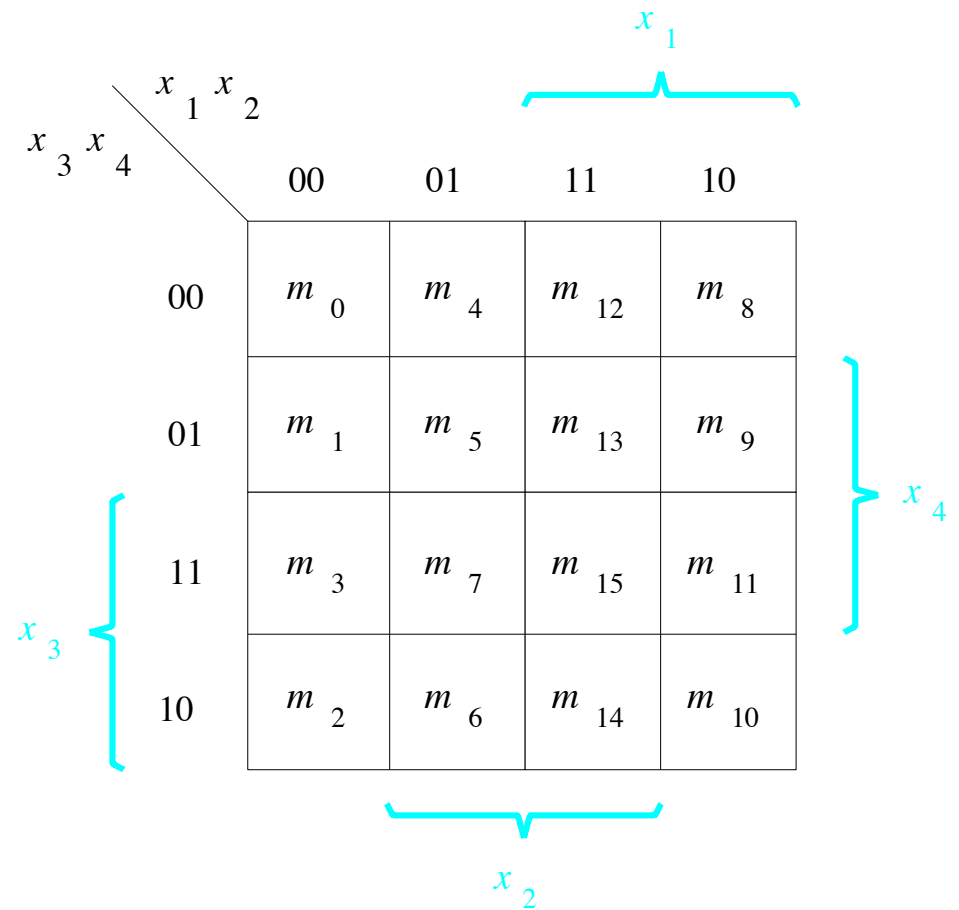

How to check if the number is > 9 ?

z3	z2	z1	z0	
0	0	0	0	m0
0	0	0	1	m1
0	0	1	0	m2
0	0	1	1	m3
<hr/>				
0	1	0	0	m4
0	1	0	1	m5
0	1	1	0	m6
0	1	1	1	m7
<hr/>				
1	0	0	0	m8
1	0	0	1	m9
1	0	1	0	m10
1	0	1	1	m11
<hr/>				
1	1	0	0	m12
1	1	0	1	m13
1	1	1	0	m14
1	1	1	1	m15

		$z_3 z_2$			
		00	01	11	10
$z_1 z_0$	00	0	0	1	0
	01	0	0	1	0
	11	0	0	1	1
	10	0	0	1	1

How to check if the number is > 9 ?

z3	z2	z1	z0	
0	0	0	0	m0
0	0	0	1	m1
0	0	1	0	m2
0	0	1	1	m3
<hr/>				
0	1	0	0	m4
0	1	0	1	m5
0	1	1	0	m6
0	1	1	1	m7
<hr/>				
1	0	0	0	m8
1	0	0	1	m9
1	0	1	0	m10
1	0	1	1	m11
<hr/>				
1	1	0	0	m12
1	1	0	1	m13
1	1	1	0	m14
1	1	1	1	m15

		z_3z_2			
		00	01	11	10
z_1z_0	00	0	0	1	0
	01	0	0	1	0
	11	0	0	1	1
	10	0	0	1	1

$$f = z_3z_2 + z_3z_1$$

How to check if the number is > 9 ?

z3	z2	z1	z0	
0	0	0	0	m0
0	0	0	1	m1
0	0	1	0	m2
0	0	1	1	m3
<hr/>				
0	1	0	0	m4
0	1	0	1	m5
0	1	1	0	m6
0	1	1	1	m7
<hr/>				
1	0	0	0	m8
1	0	0	1	m9
1	0	1	0	m10
1	0	1	1	m11
<hr/>				
1	1	0	0	m12
1	1	0	1	m13
1	1	1	0	m14
1	1	1	1	m15

		$z_3 z_2$			
		00	01	11	10
$z_1 z_0$	00	0	0	1	0
	01	0	0	1	0
	11	0	0	1	1
	10	0	0	1	1

$$f = z_3 z_2 + z_3 z_1$$

In addition, also check if there was a carry

$$f = \text{carry-out} + z_3 z_2 + z_3 z_1$$

Verilog code for a one-digit BCD adder

```
module bcdadd(Cin, X, Y, S, Cout);  
    input Cin;  
    input [3:0] X, Y;  
    output reg [3:0] S;  
    output reg Cout;  
    reg [4:0] Z;  
  
    always@ (X, Y, Cin)  
    begin  
        Z = X + Y + Cin;  
        if (Z < 10)  
            {Cout, S} = Z;  
        else  
            {Cout, S} = Z + 6;  
    end  
  
endmodule
```

Circuit for a one-digit BCD adder

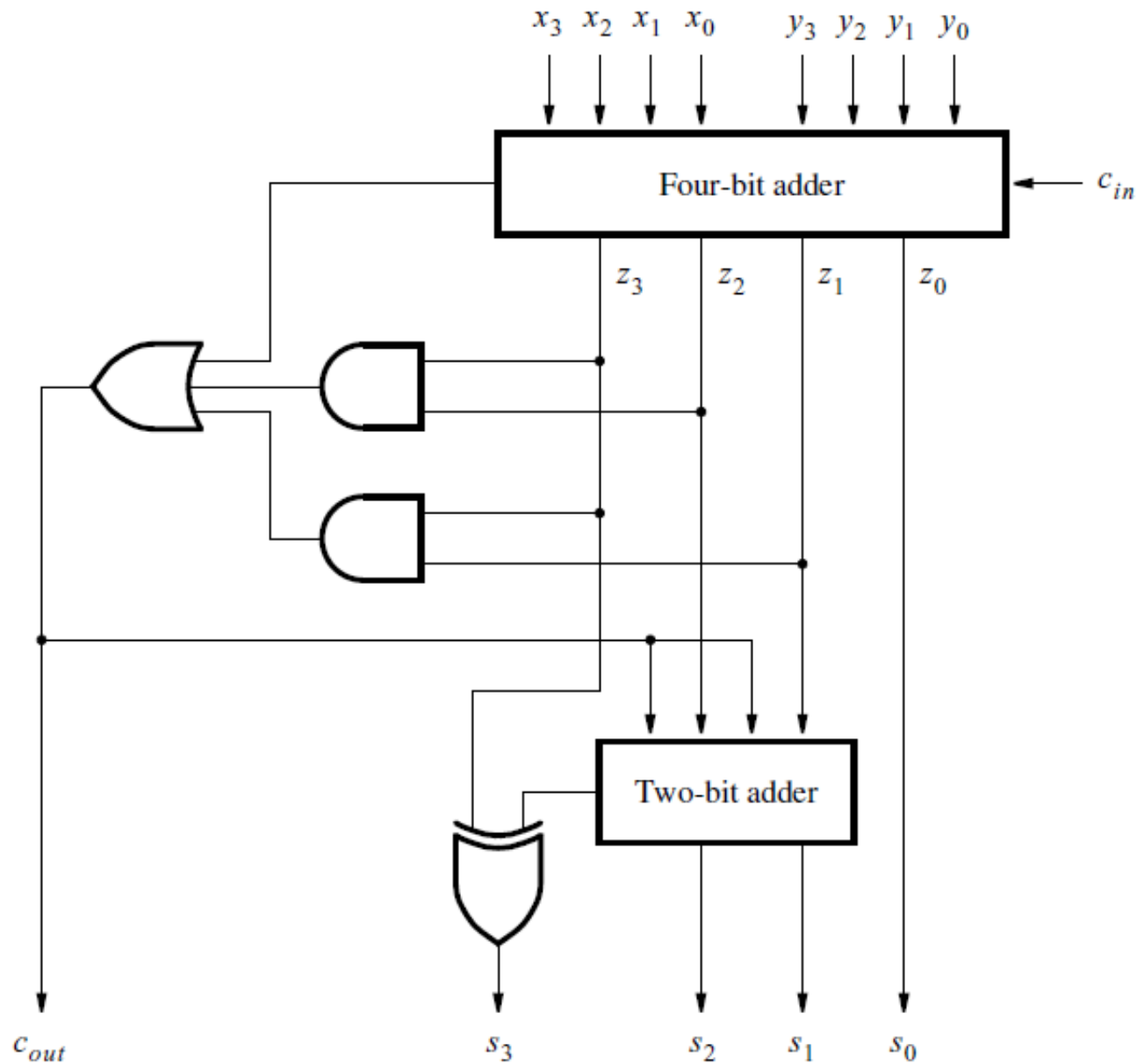

[Figure 3.41 in the textbook]

Circuit for a one-digit BCD adder

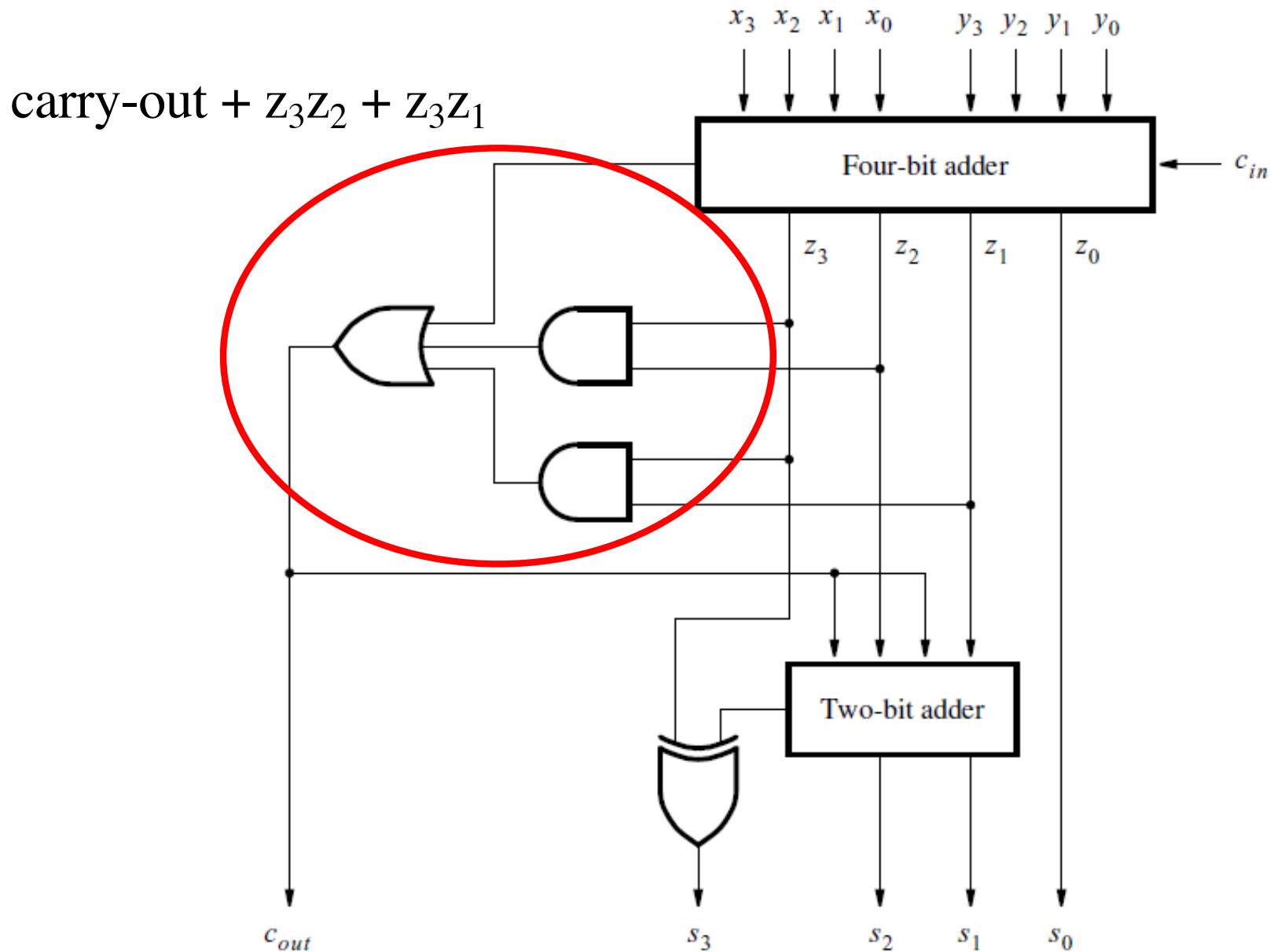

[Figure 3.41 in the textbook]

Circuit for a one-digit BCD adder

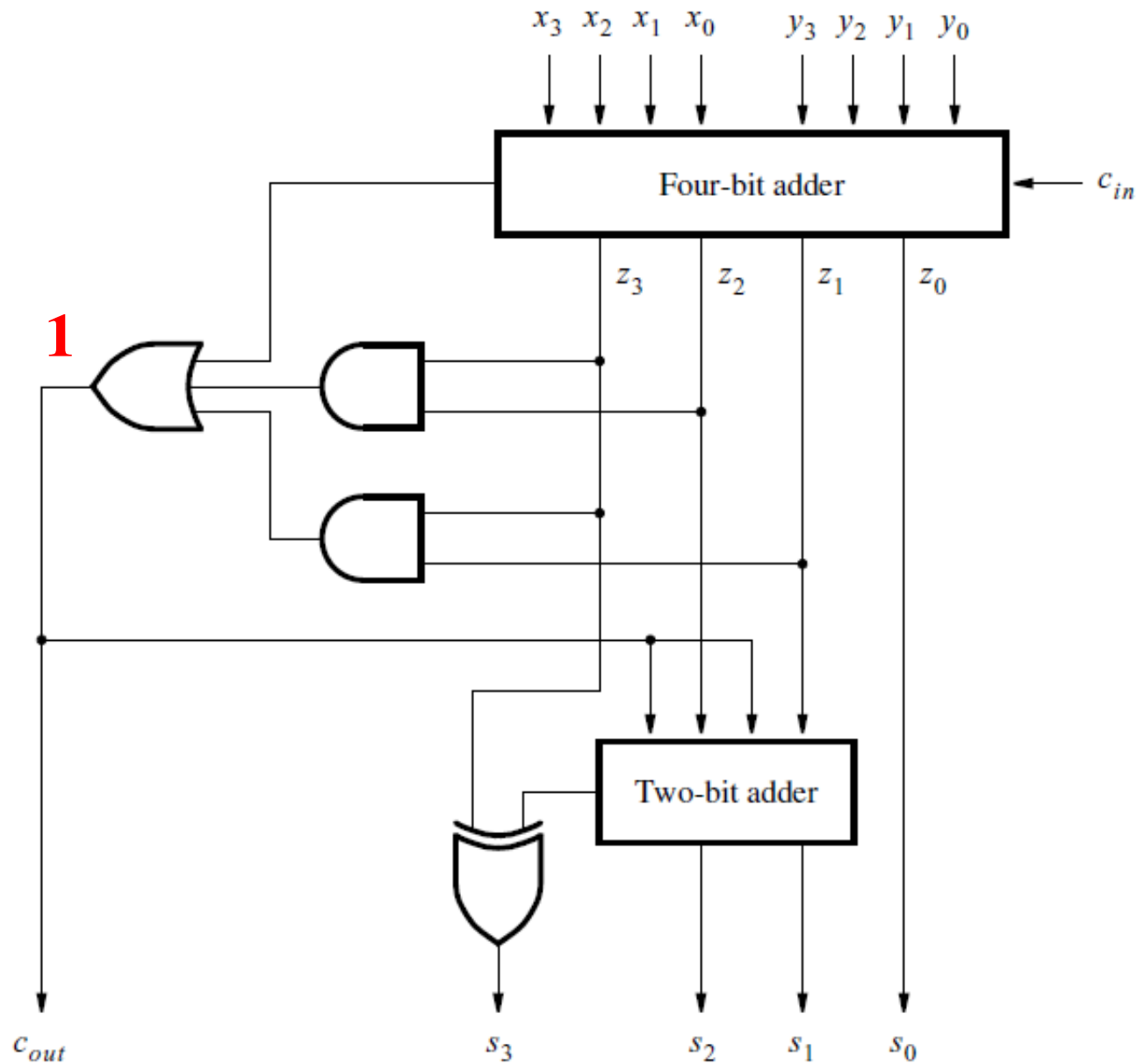

[Figure 3.41 in the textbook]

Circuit for a one-digit BCD adder

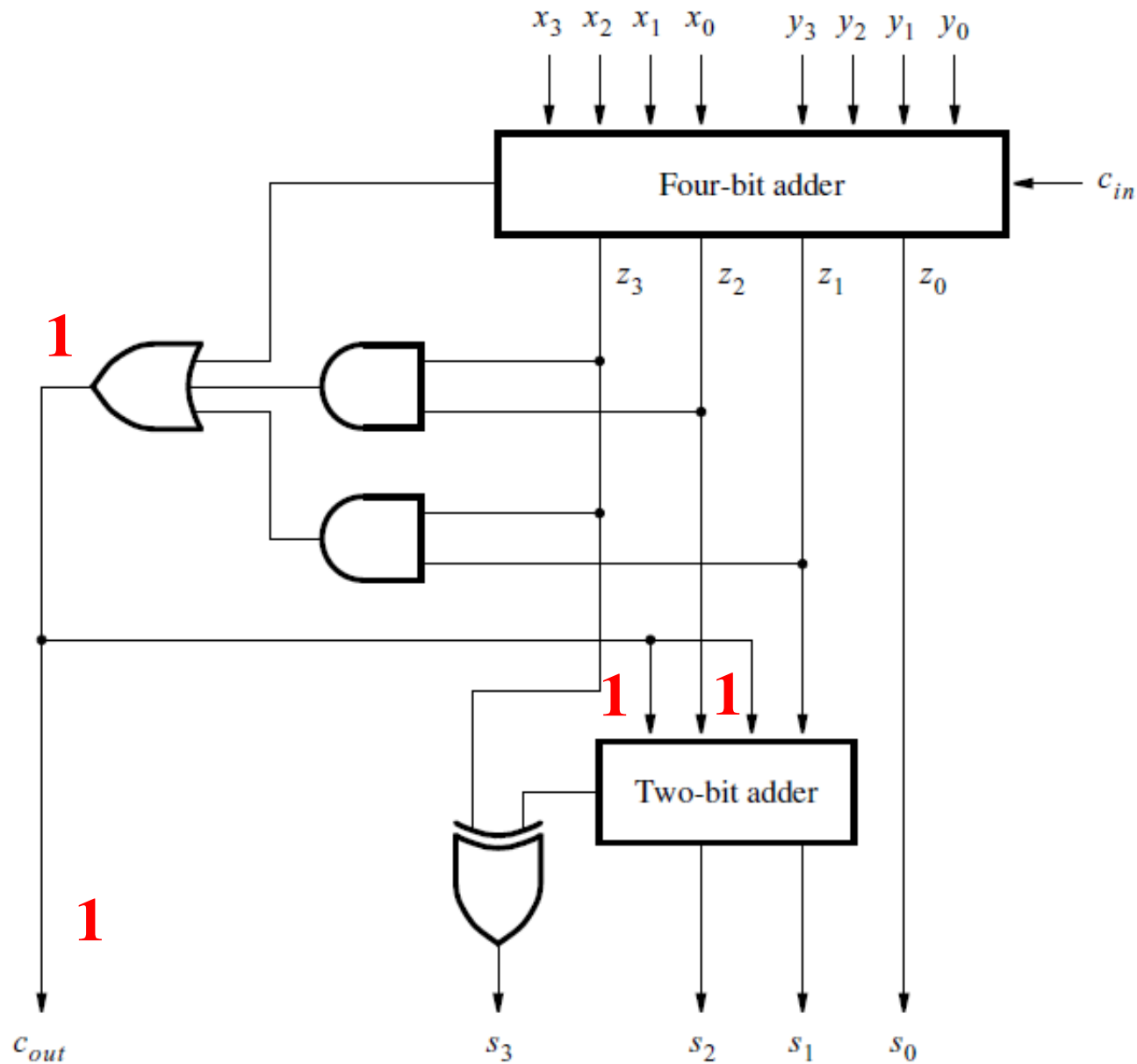

[Figure 3.41 in the textbook]

Circuit for a one-digit BCD adder

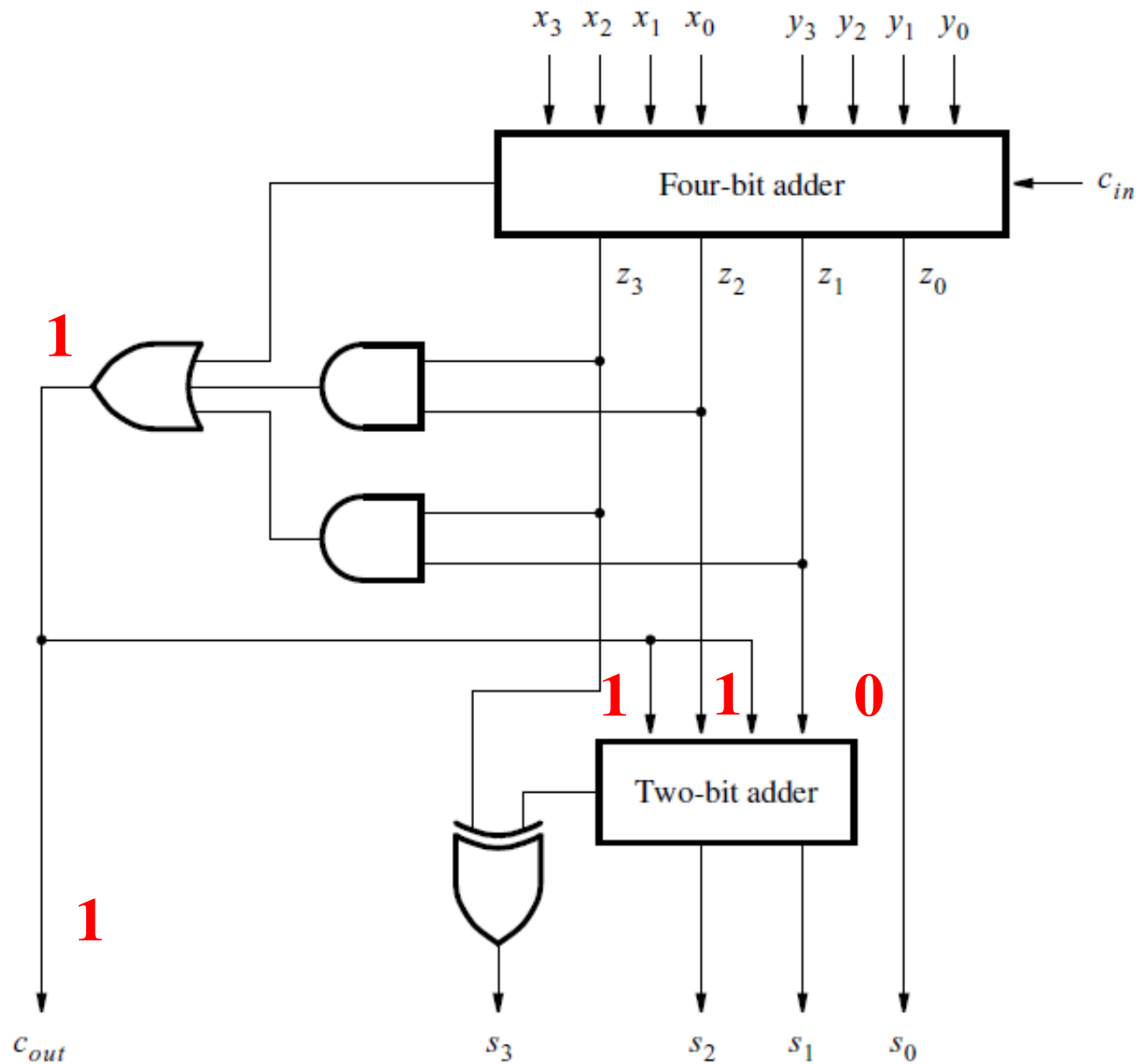

[Figure 3.41 in the textbook]

Circuit for a one-digit BCD adder

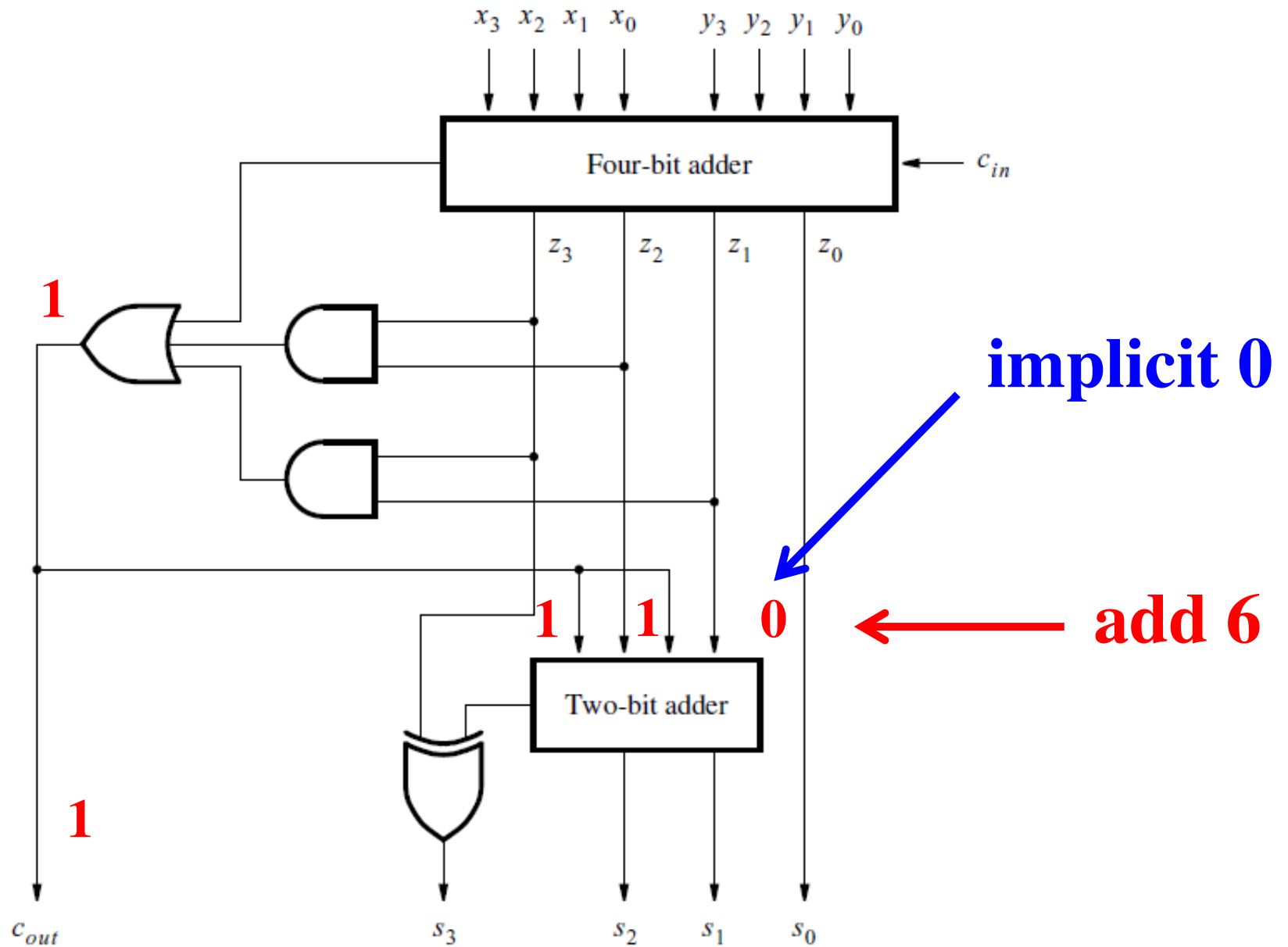

[Figure 3.41 in the textbook]

Questions?

THE END