



CprE 281: Digital Logic

Instructor: Alexander Stoytchev

<http://www.ece.iastate.edu/~alexs/classes/>

Registers

CprE 281: Digital Logic
Iowa State University, Ames, IA
Copyright © Alexander Stoytchev

Administrative Stuff

- **Homework 8 is due next Monday.**
- **The second midterm exam is next Friday.**

Administrative Stuff

- **Midterm Exam #2**
- **When: Friday November 1 @ 4pm.**
- **Where: This classroom**
- **What: Chapters 1, 2, 3, 4 and 5.1-5.8**
- **The exam will be closed book but open notes (you can bring up to 3 pages of handwritten notes).**

Midterm 2: Format

- **The exam will be out of 130 points**
- **You need 95 points to get an A for this exam**
- **It will be great if you can score more than 100 points.**
 - **but you can't roll over your extra points 😞**

Midterm 2: Topics

- **Binary Numbers and Hexadecimal Numbers**
- **1's complement and 2's complement representation**
- **Addition and subtraction of binary numbers**
- **Circuits for adders and fast adders**

- **Single and Double precision IEEE floating point formats**
- **Converting a real number to the IEEE format**
- **Converting a floating point number to base 10**

- **Multiplexers (circuits and function)**
- **Synthesis of logic functions using multiplexers**
- **Shannon's Expansion Theorem**

Midterm 2: Topics

- **Decoders (circuits and function)**
- **Demultiplexers**
- **Encoders (binary and priority)**
- **Code Converters**
- **K-maps for 2, 3, and 4 variables**

- **Synthesis of logic circuits using adders, multiplexers, encoders, decoders, and basic logic gates**
- **Synthesis of logic circuits given constraints on the available building blocks that you can use**

- **Latches (circuits, behavior, timing diagrams)**
- **Flip-Flops (circuits, behavior, timing diagrams)**
- **Registers and Register Files**

Review of Flip-Flops

A simple memory element with NOT Gates

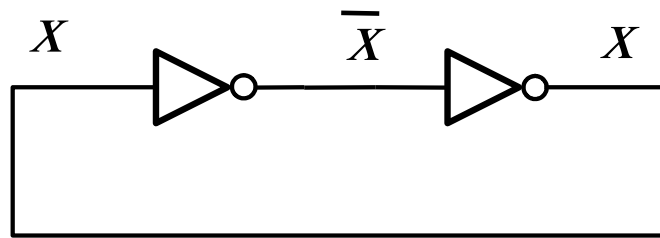

A simple memory element with NAND Gates

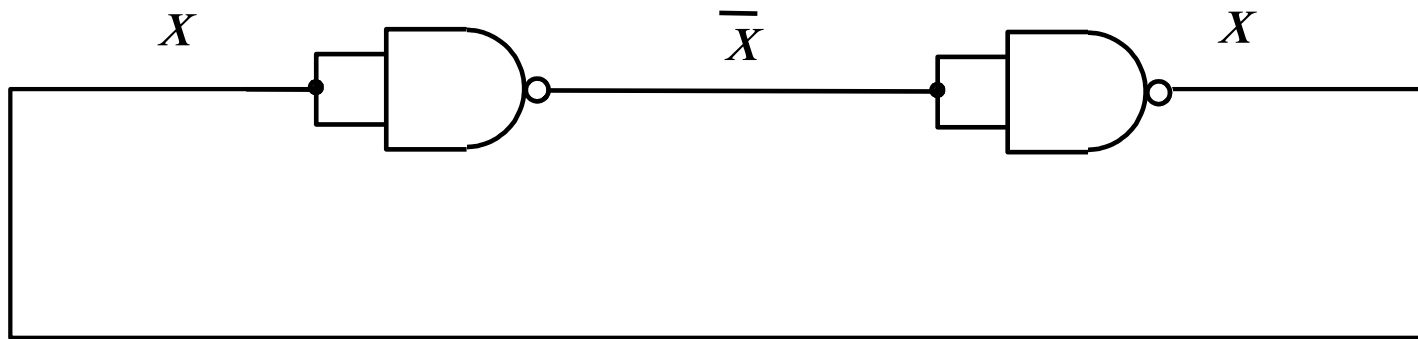

A simple memory element with NOR Gates

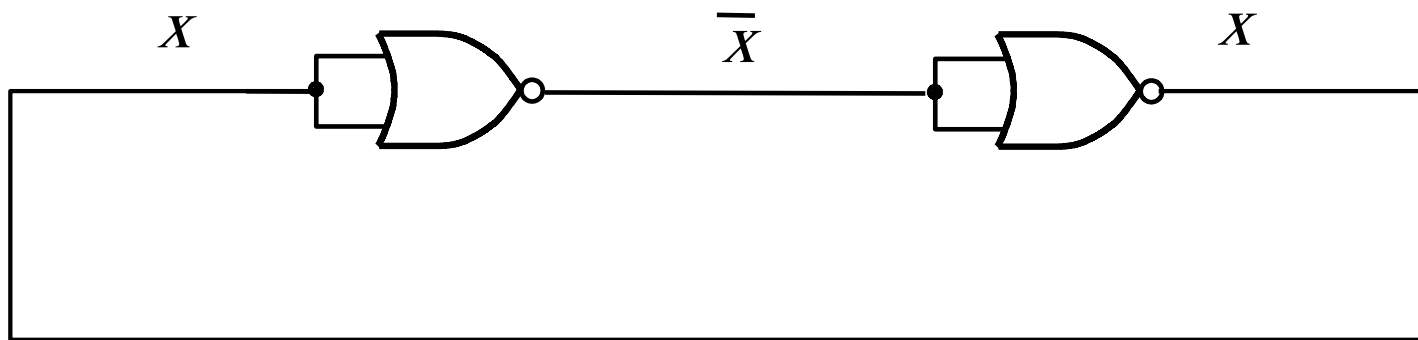

Basic Latch

A simple memory element with NOR Gates

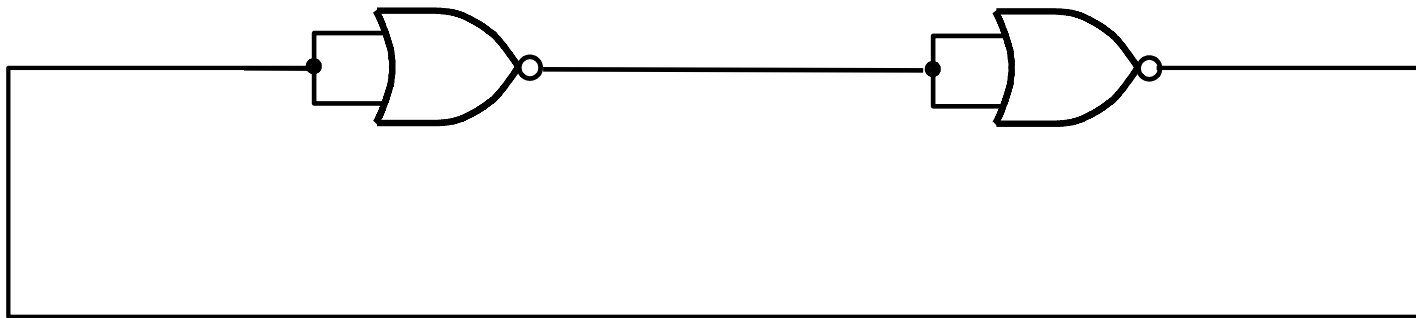

A simple memory element with NOR Gates

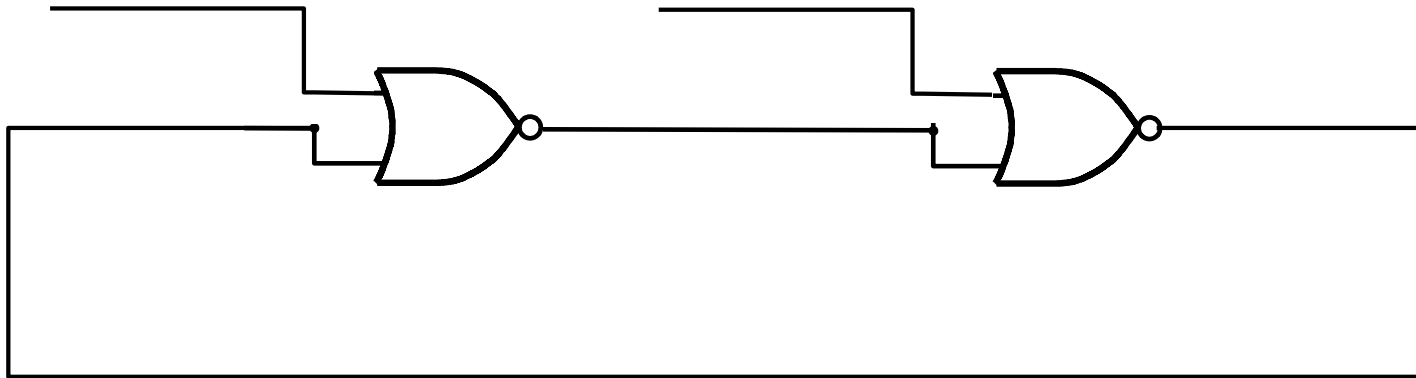

A simple memory element with NOR Gates

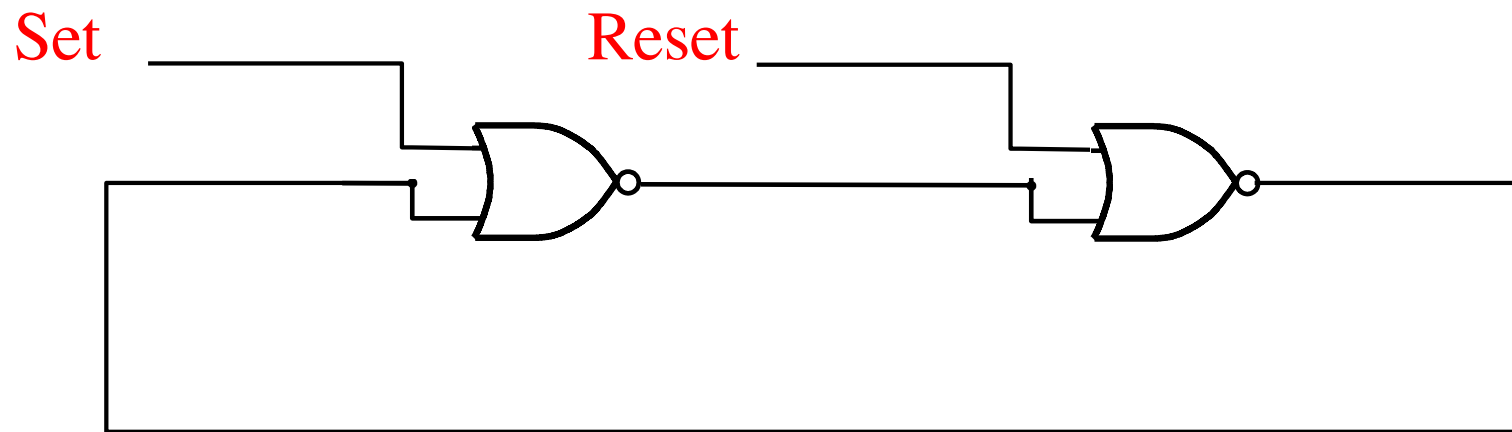

A memory element with NOR gates

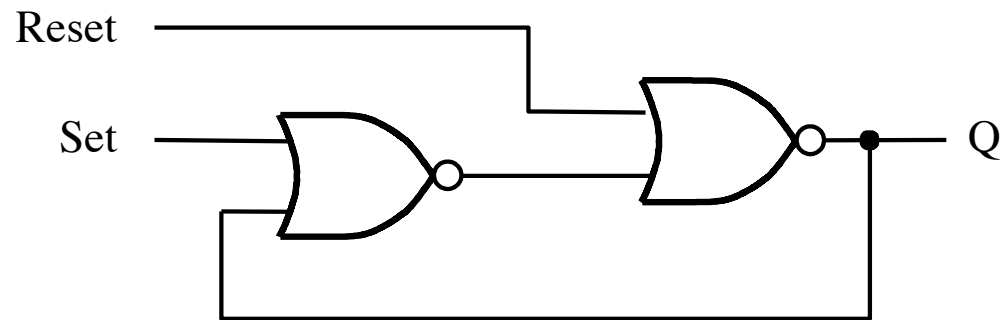

Two Different Ways to Draw the Same Circuit

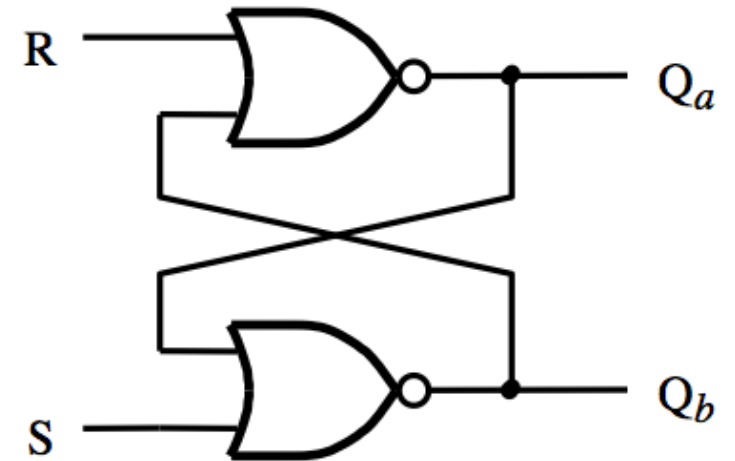
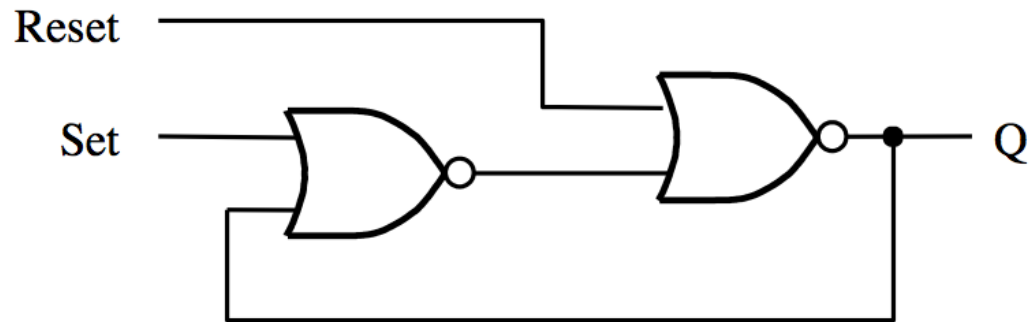

[Figure 5.3 & 5.4 from the textbook]

SR Latch: Circuit and Truth Table

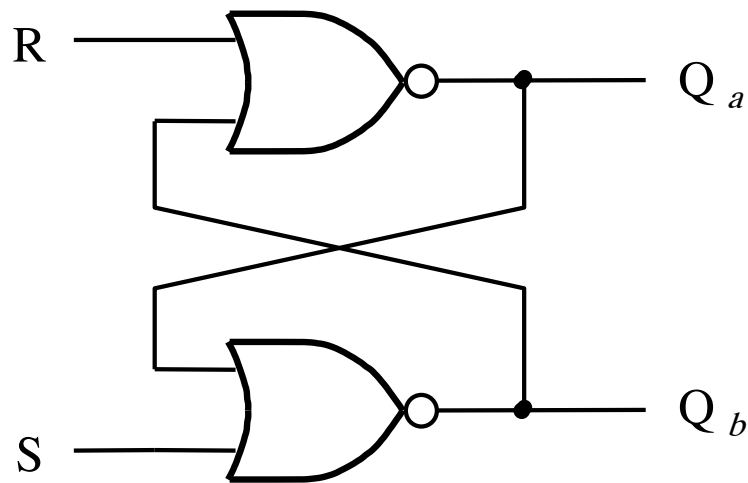

(a) Circuit

S	R	Q_a	Q_b	
0	0	0/1	1/0	(no change)
0	1	0	1	
1	0	1	0	
1	1	0	0	(Undesirable)

(b) Truth table

[Figure 5.4a,b from the textbook]

NOR Gate

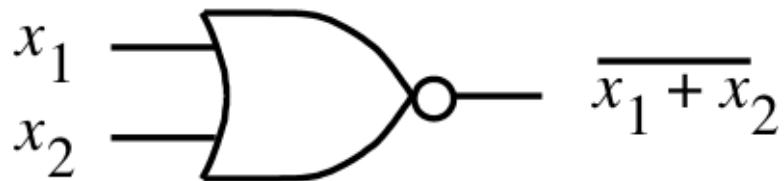

NOR Gate Truth table

x_1	x_2	f
0	0	1
0	1	0
1	0	0
1	1	0

Gated SR Latch

Circuit Diagram for the Gated SR Latch

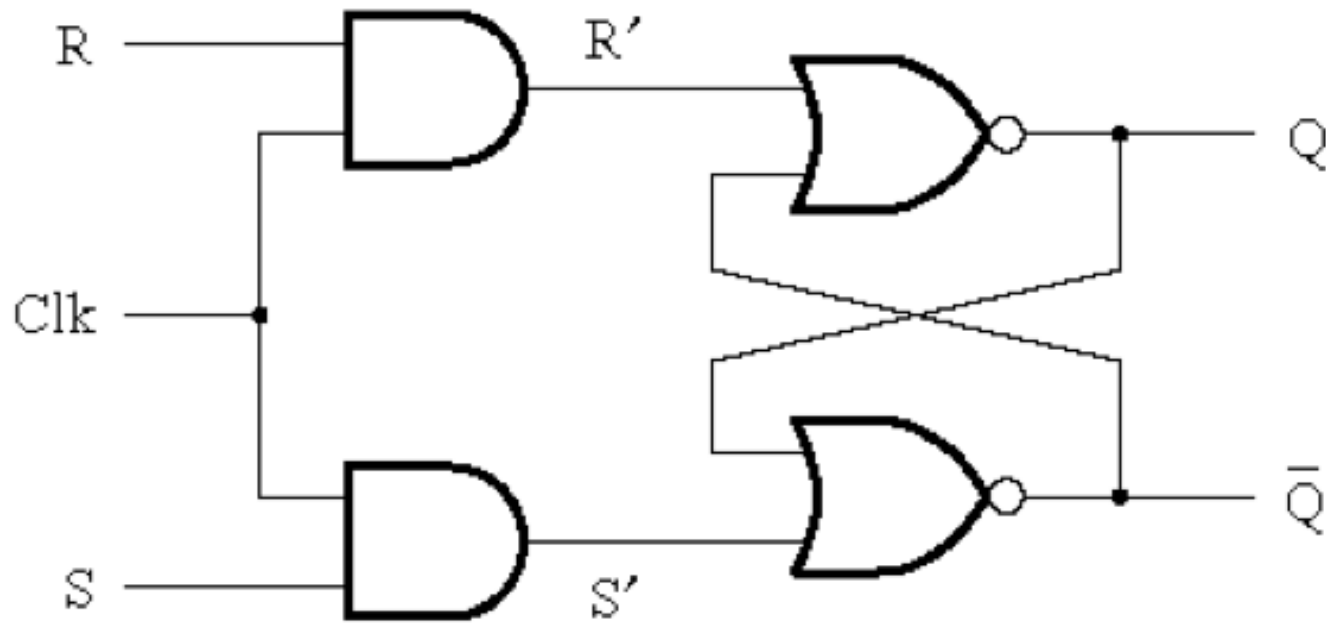

[Figure 5.5a from the textbook]

Circuit Diagram for the Gated SR Latch

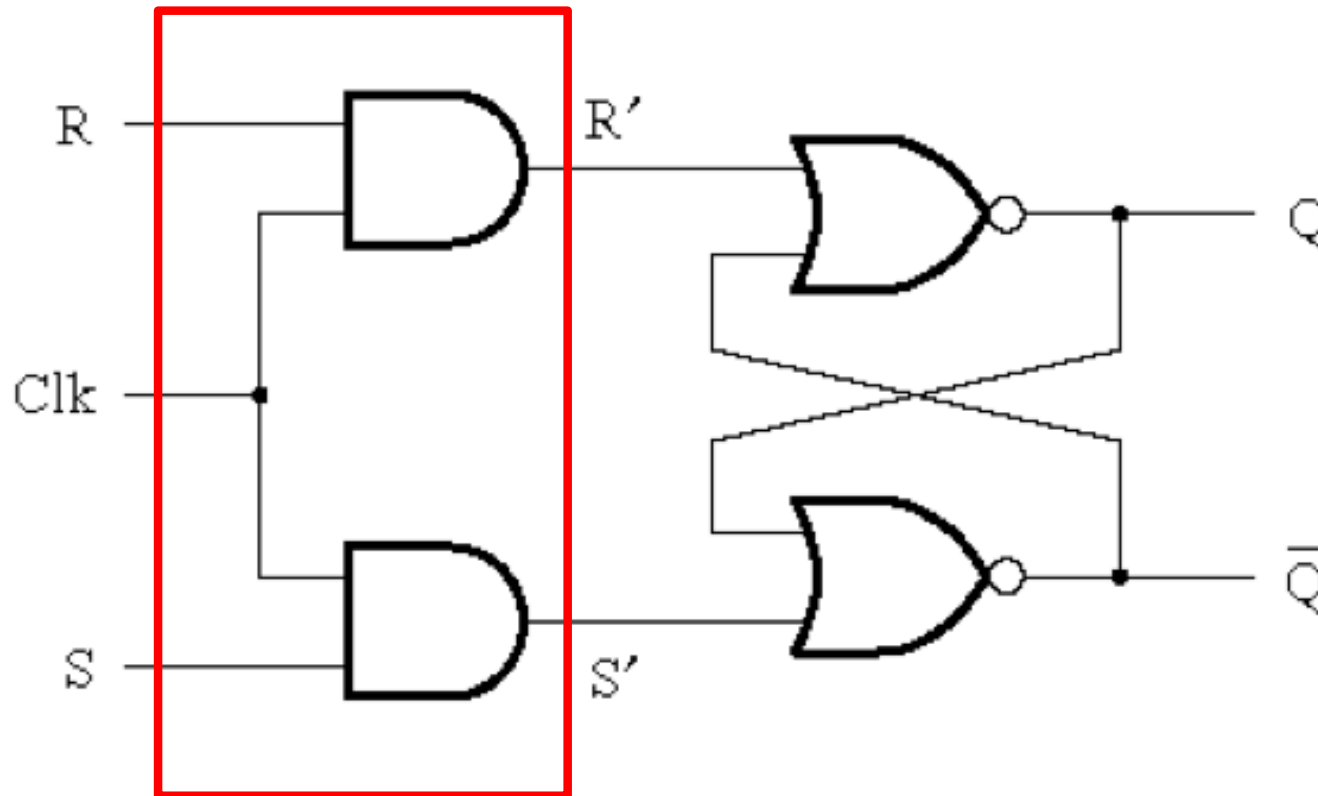

This is the “gate”
of the gated latch

Circuit Diagram for the Gated SR Latch

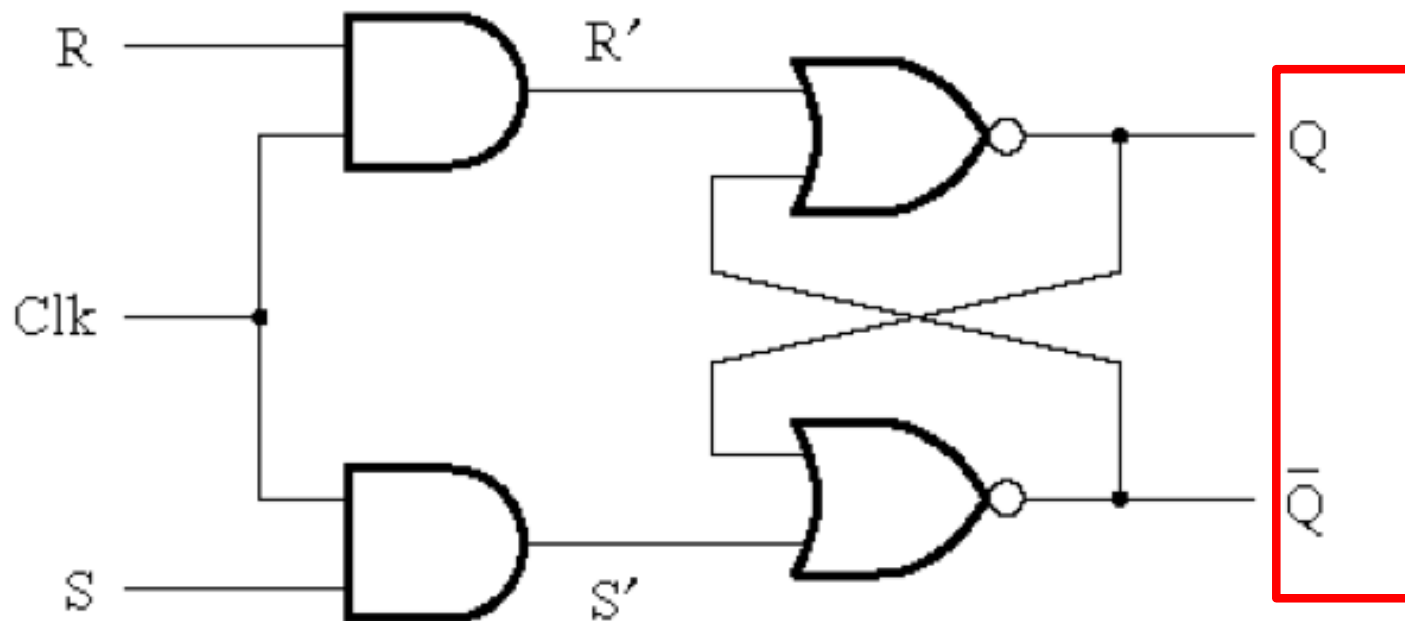

Notice that these are complements of each other

Gated SR Latch: Circuit Diagram, Characteristic Table, and Graphical Symbol

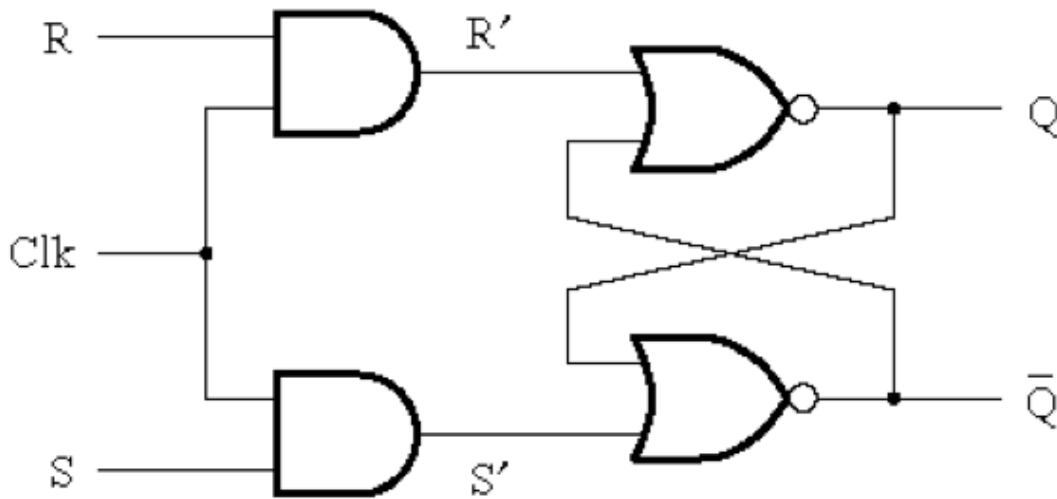

Clk	S	R	$Q(t + 1)$
0	x	x	$Q(t)$ (no change)
1	0	0	$Q(t)$ (no change)
1	0	1	0
1	1	0	1
1	1	1	x (Undesirable)

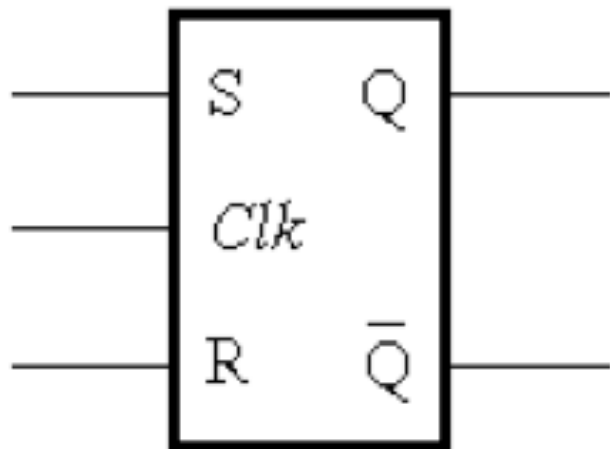

[Figure 5.5 from the textbook]

Gated SR latch with NAND gates

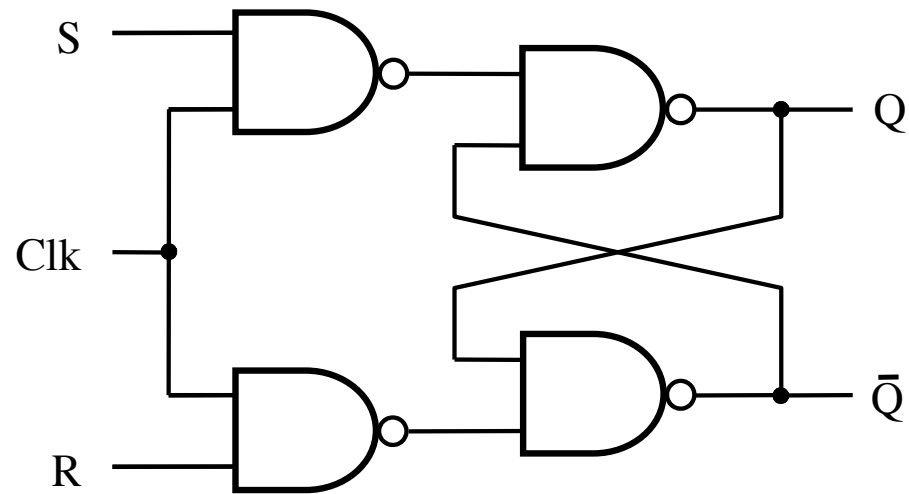

Gated SR latch with NAND gates

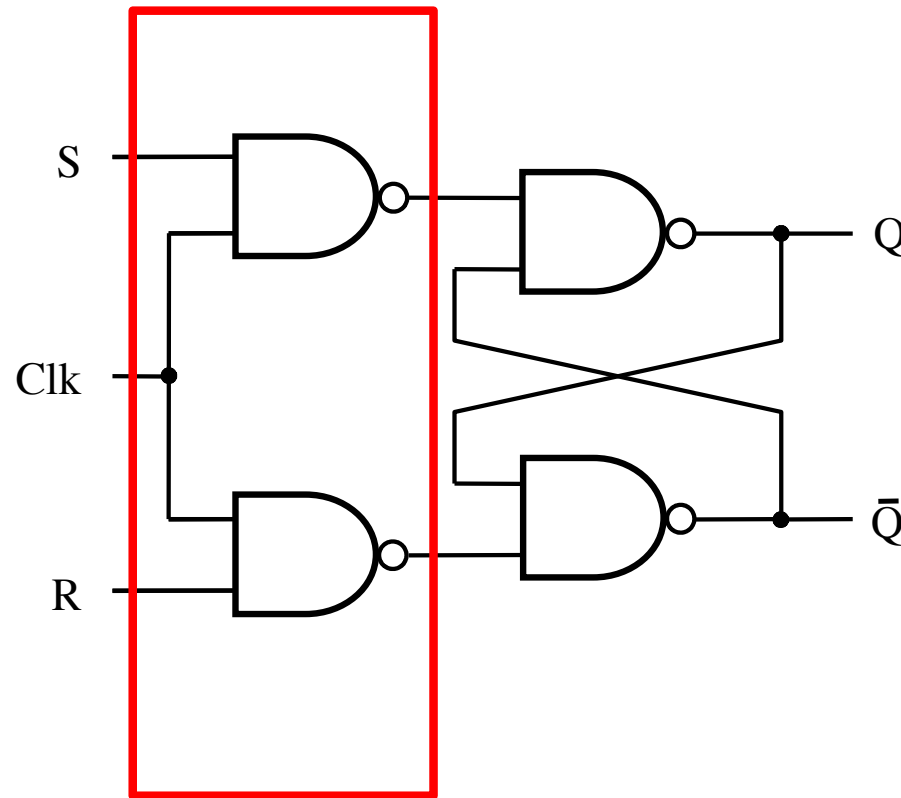

In this case the “gate” is constructed using NAND gates! Not AND gates.

Gated SR latch with NAND gates

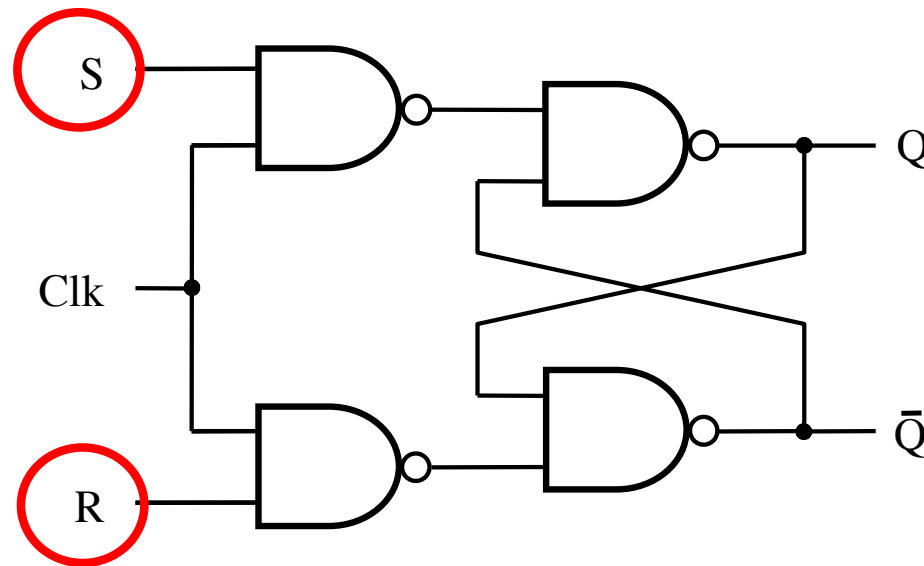

Also, notice that the positions of S and R are now swapped.

Gated SR latch with NAND gates

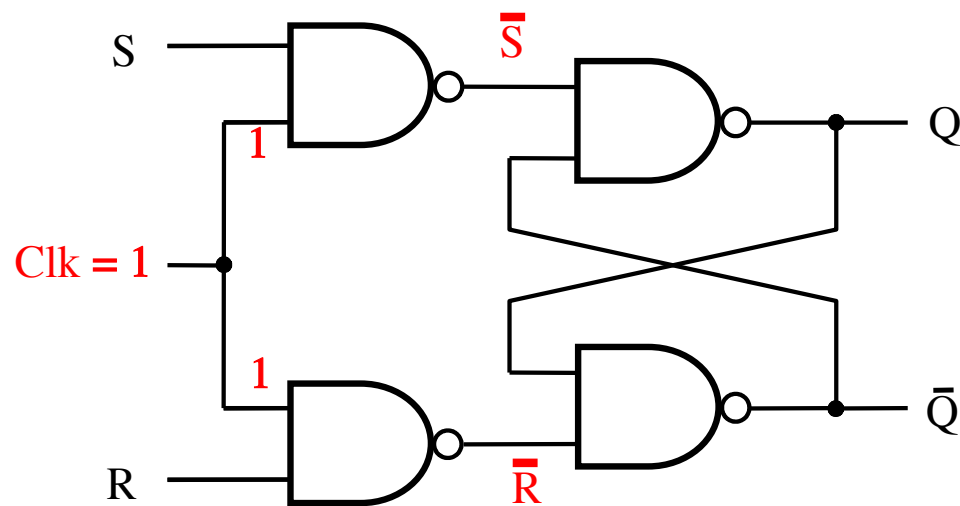

Finally, notice that when $\text{Clk}=1$ this turns into the basic latch with NAND gates, i.e., the $\bar{S}\bar{R}$ Latch.

Gated SR latch with NOR gates

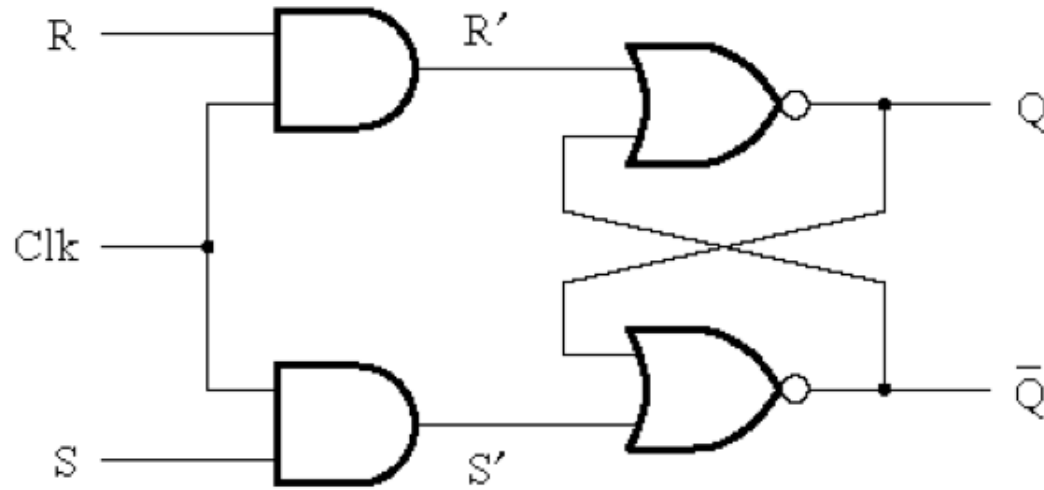

Gated SR latch with NAND gates

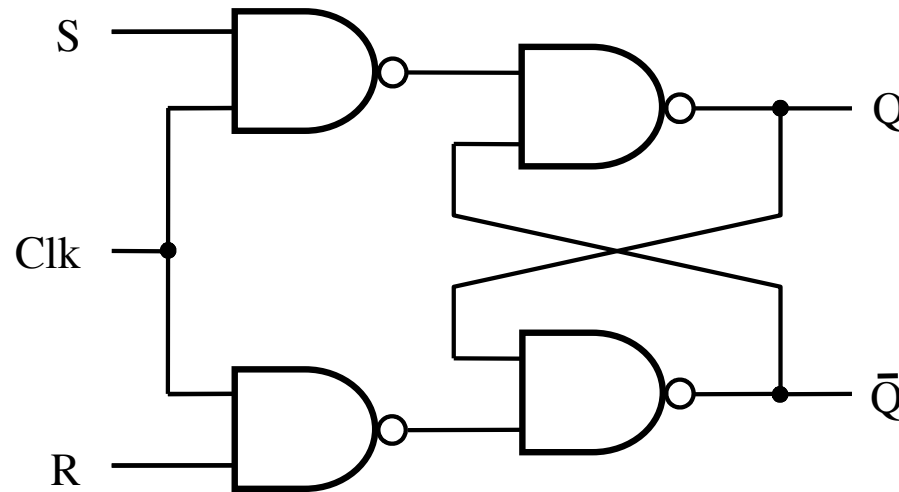

Gated SR latch with NOR gates

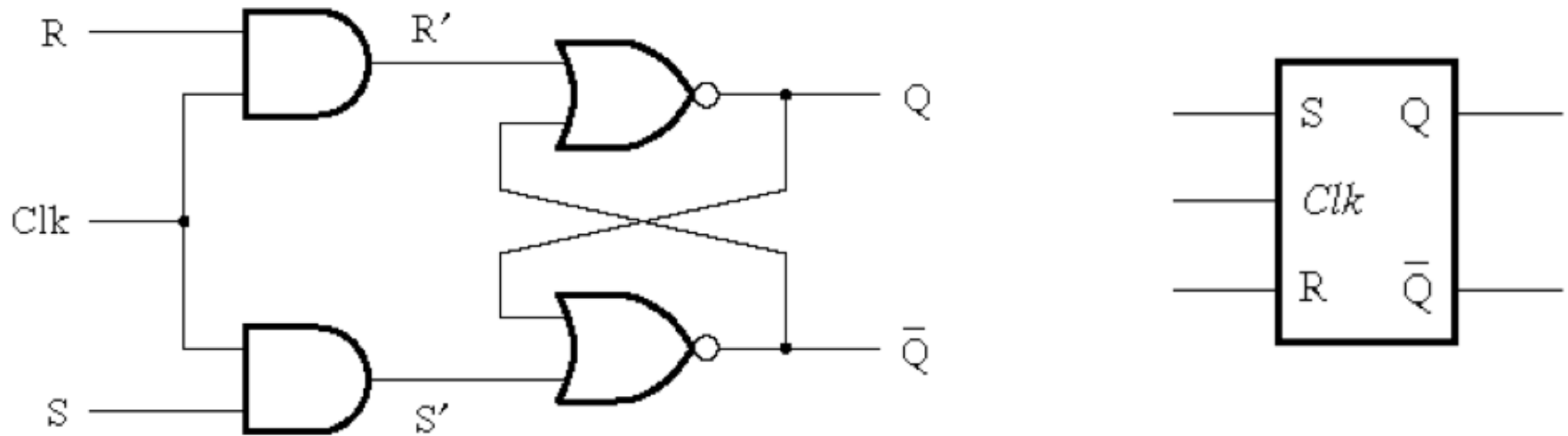

Gated SR latch with NAND gates

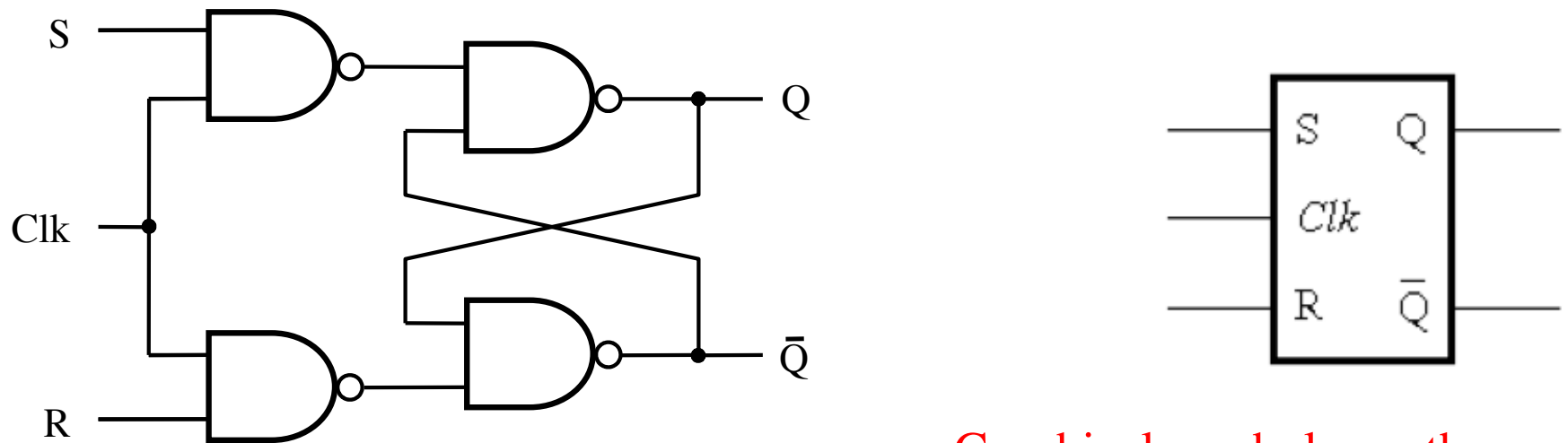

Graphical symbols are the same

Gated SR latch with NOR gates

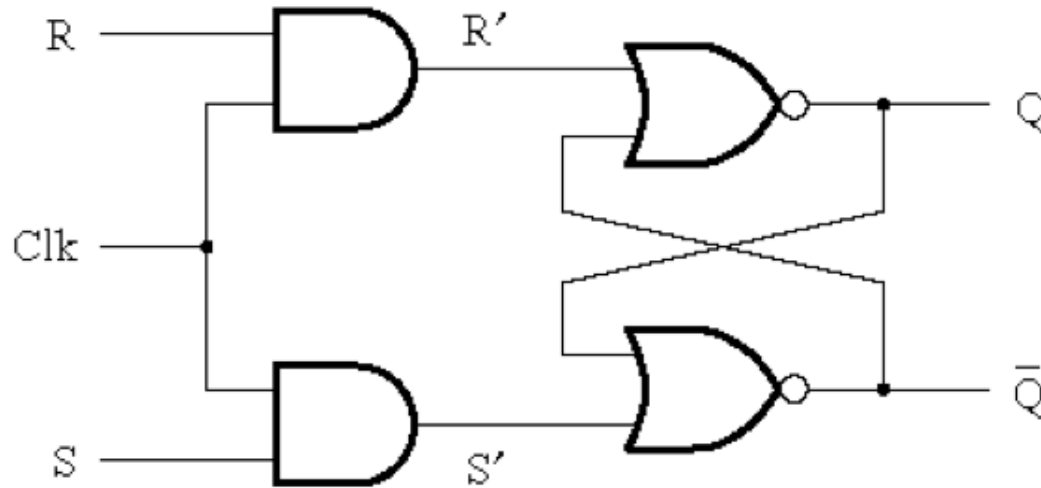

Clk	S	R	$Q(t+1)$
0	x	x	$Q(t)$ (no change)
1	0	0	$Q(t)$ (no change)
1	0	1	0
1	1	0	1
1	1	1	x (undesirable)

Gated SR latch with NAND gates

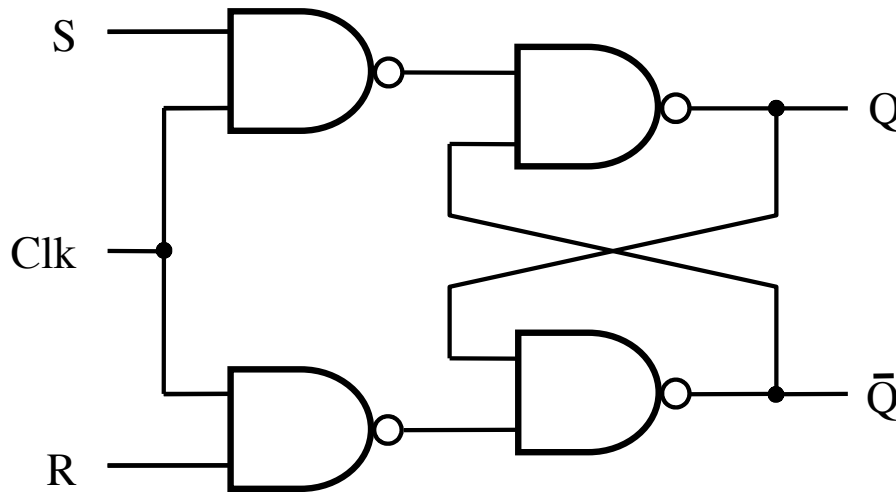

Clk	S	R	$Q(t+1)$
0	x	x	$Q(t)$ (no change)
1	0	0	$Q(t)$ (no change)
1	0	1	0
1	1	0	1
1	1	1	x (undesirable)

Characteristic tables are the same

Gated D Latch

Circuit Diagram for the Gated D Latch

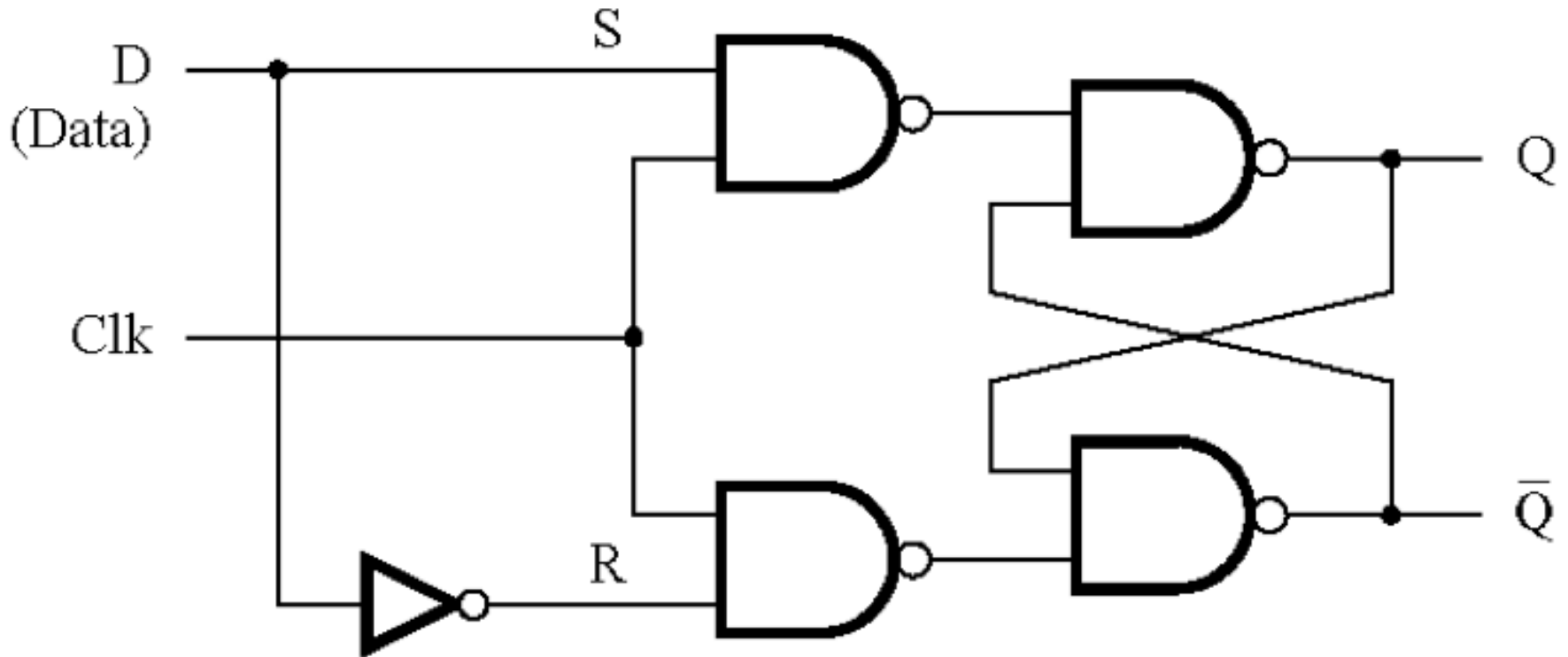

[Figure 5.7a from the textbook]

Gated D Latch: Alternative Design

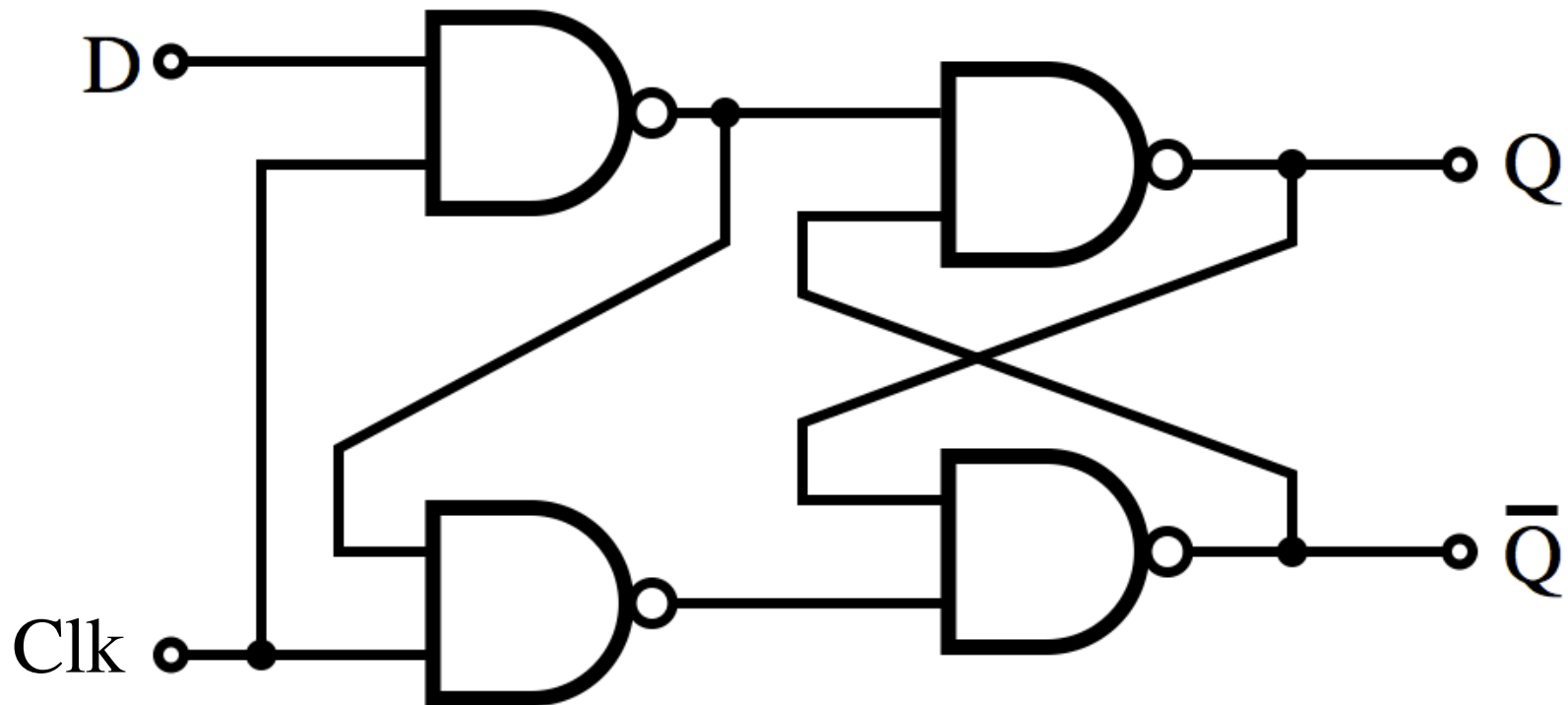

Gated D Latch: Circuit Diagram, Characteristic Table, and Graphical Symbol

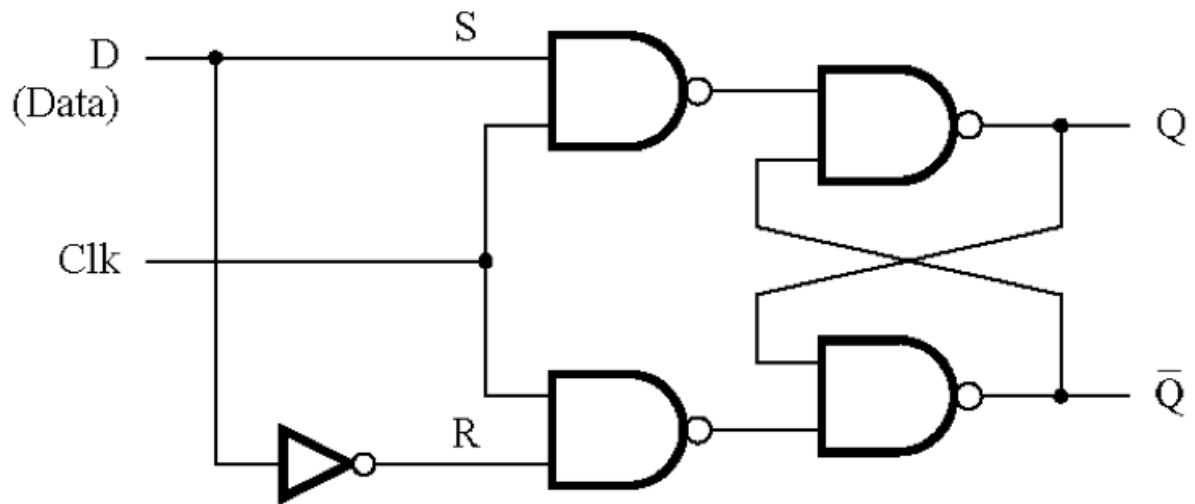

Clk	D	$Q(t+1)$
0	x	$Q(t)$
1	0	0
1	1	1

Note that it is now impossible to have $S=R=1$.

When $Clk=1$ the output follows the D input.

When $Clk=0$ the output cannot be changed.

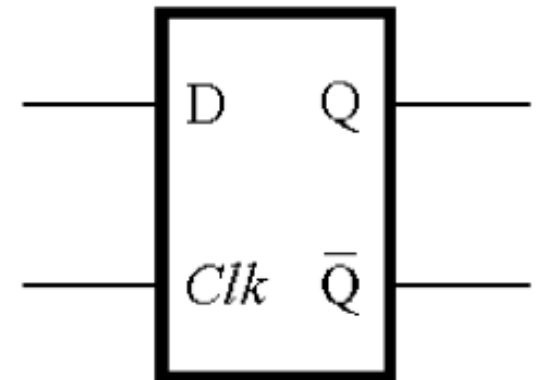

[Figure 5.7a,b from the textbook]

Setup and hold times for Gated D latch

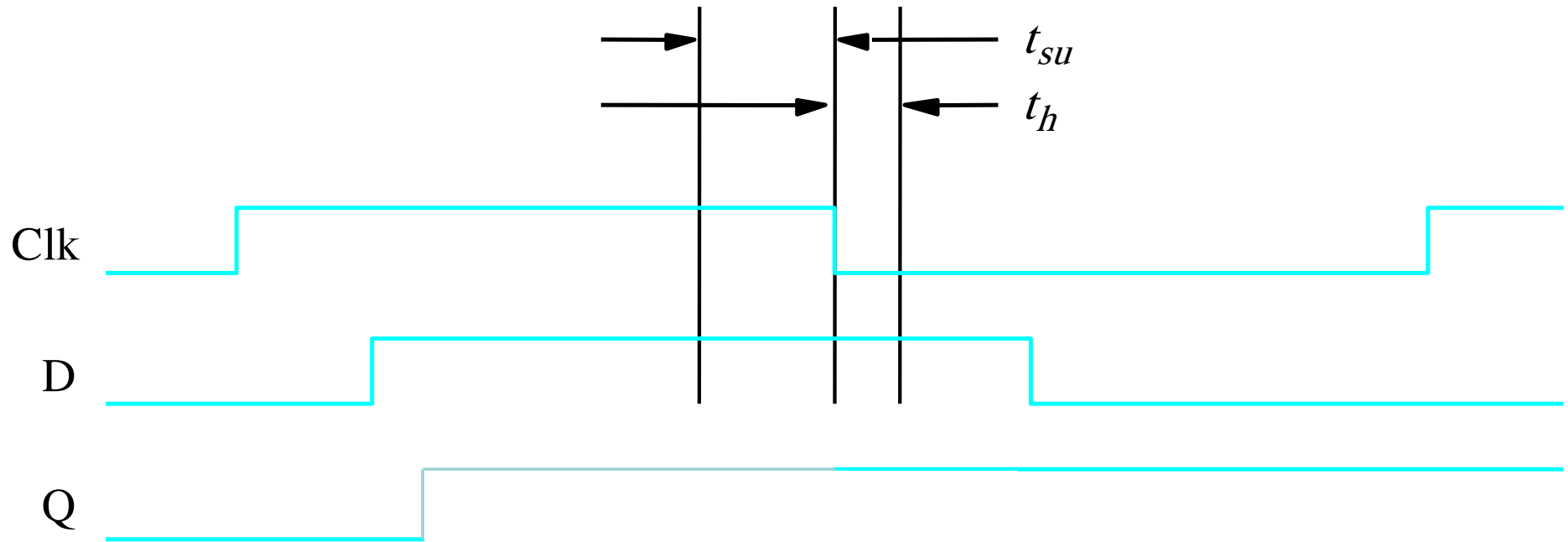

Setup time (t_{su}) – the minimum time that the D signal must be stable prior to the the negative edge of the Clock signal

Hold time (t_h) – the minimum time that the D signal must remain stable after the the negative edge of the Clock signal

Master-Slave D Flip-Flop

Constructing a Master-Slave D Flip-Flop From Two D Latches

Master

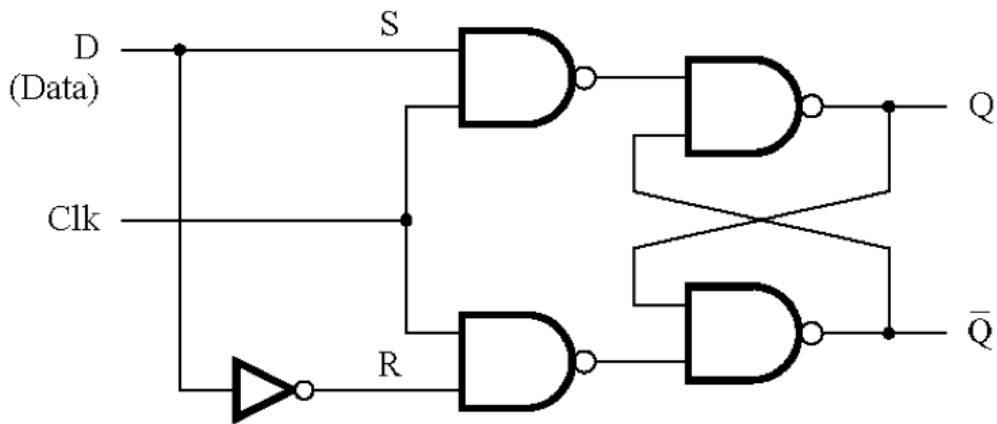

Slave

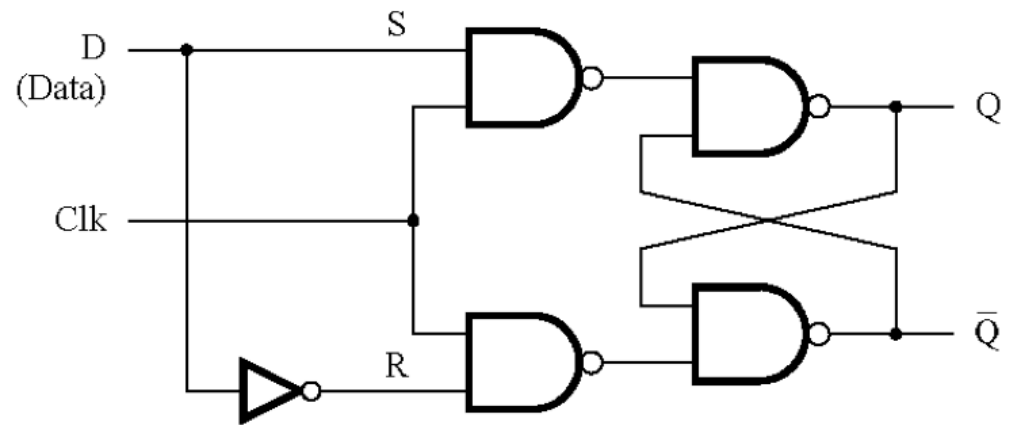

Constructing a Master-Slave D Flip-Flop From Two D Latches

Master

Slave

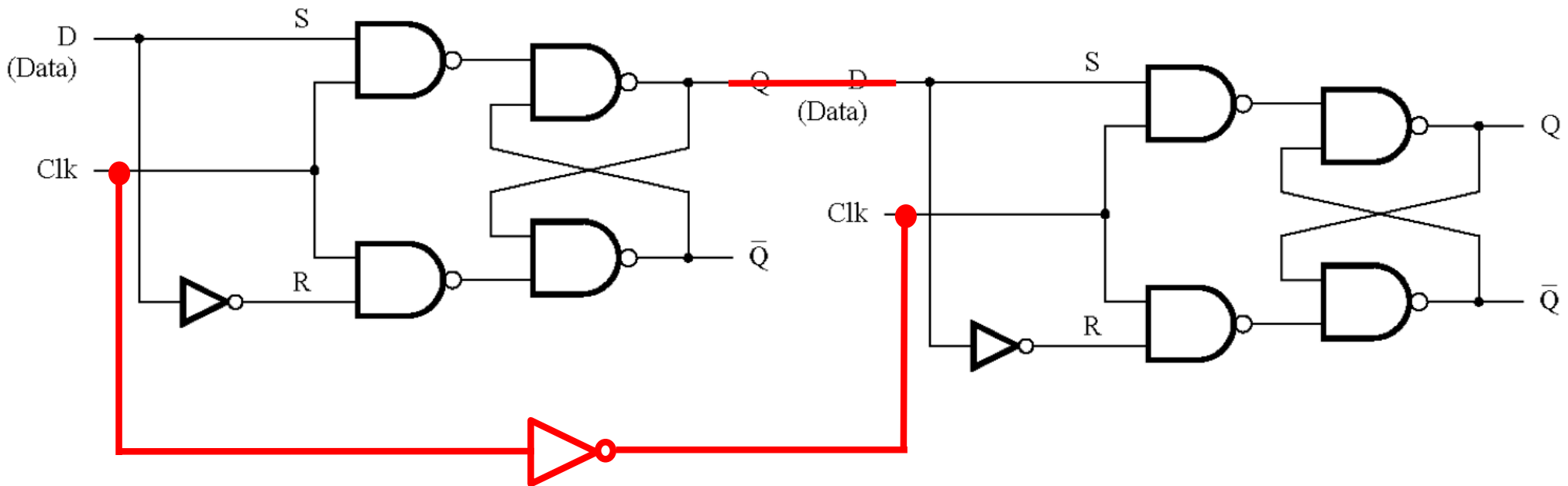

Constructing a Master-Slave D Flip-Flop From Two D Latches

Master

Slave

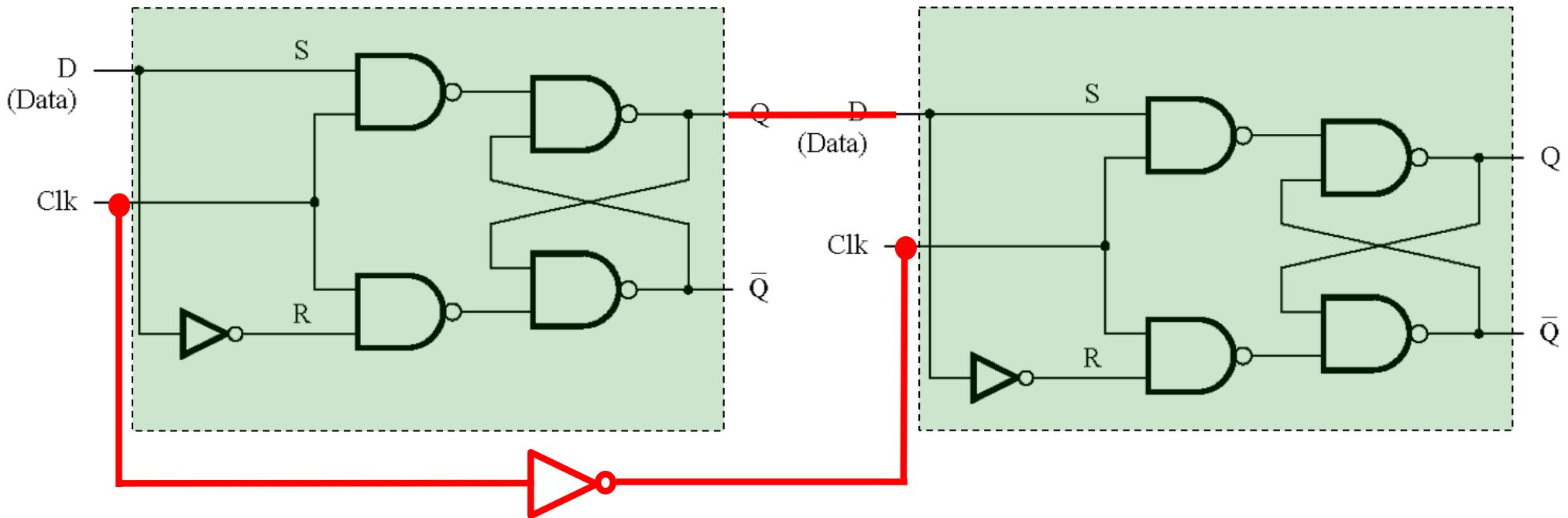

Constructing a Master-Slave D Flip-Flop From Two D Latches

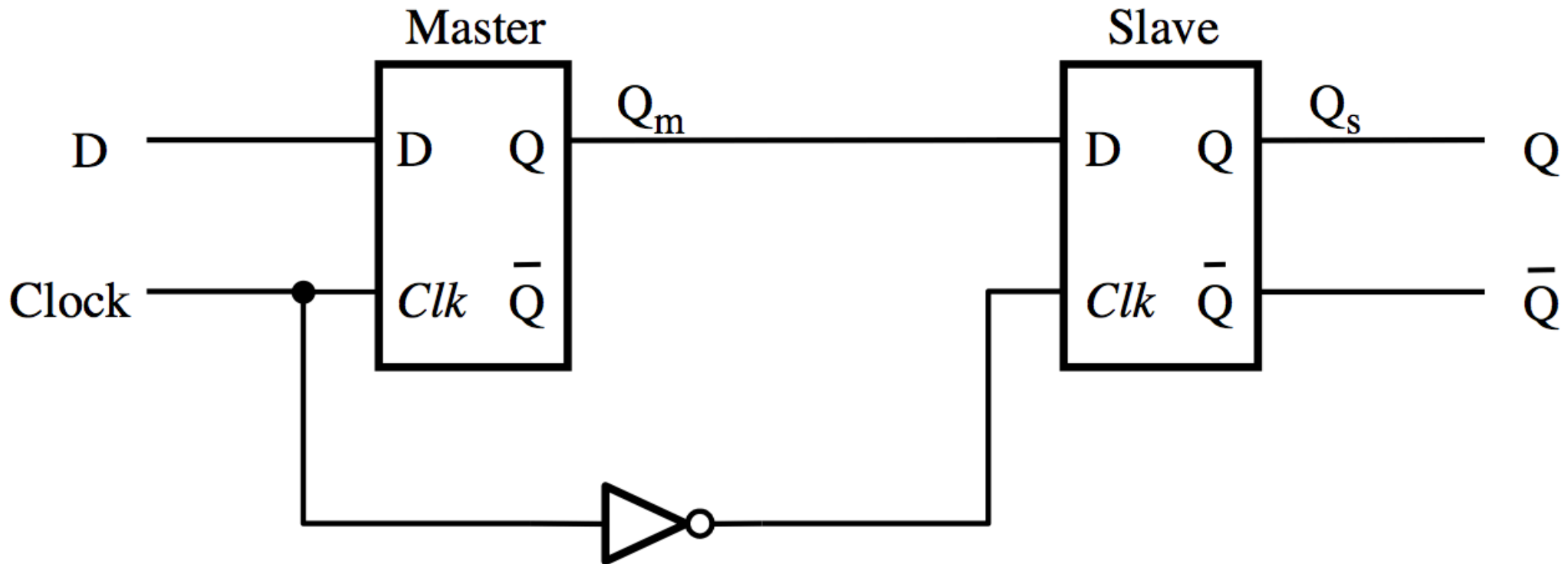

[Figure 5.9a from the textbook]

Constructing a Master-Slave D Flip-Flop From one D Latch and one Gated SR Latch

(This version uses one less NOT gate)

Master

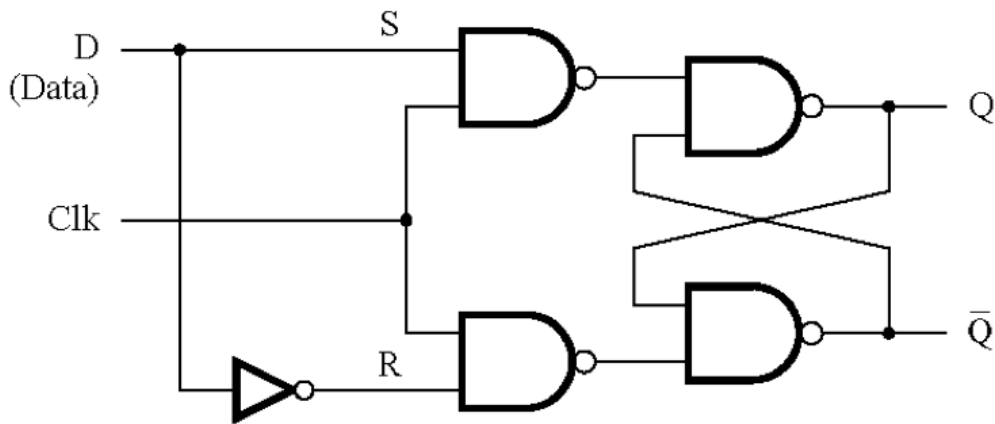

Slave

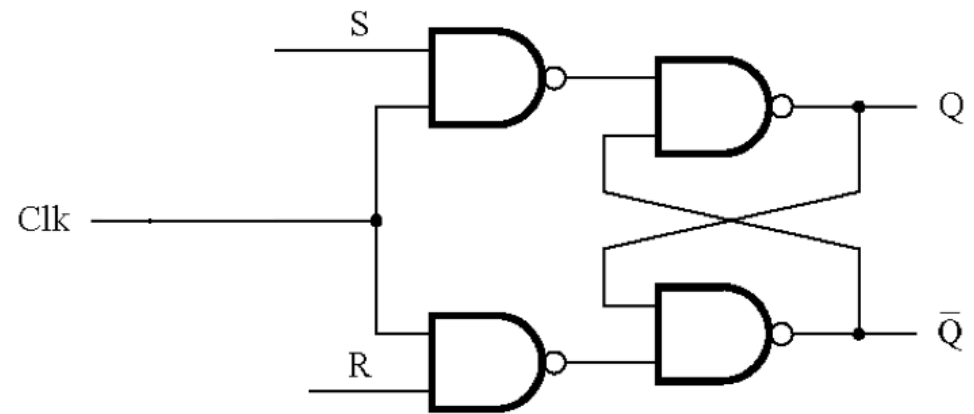

Constructing a Master-Slave D Flip-Flop From one D Latch and one Gated SR Latch

(This version uses one less NOT gate)

Master

Slave

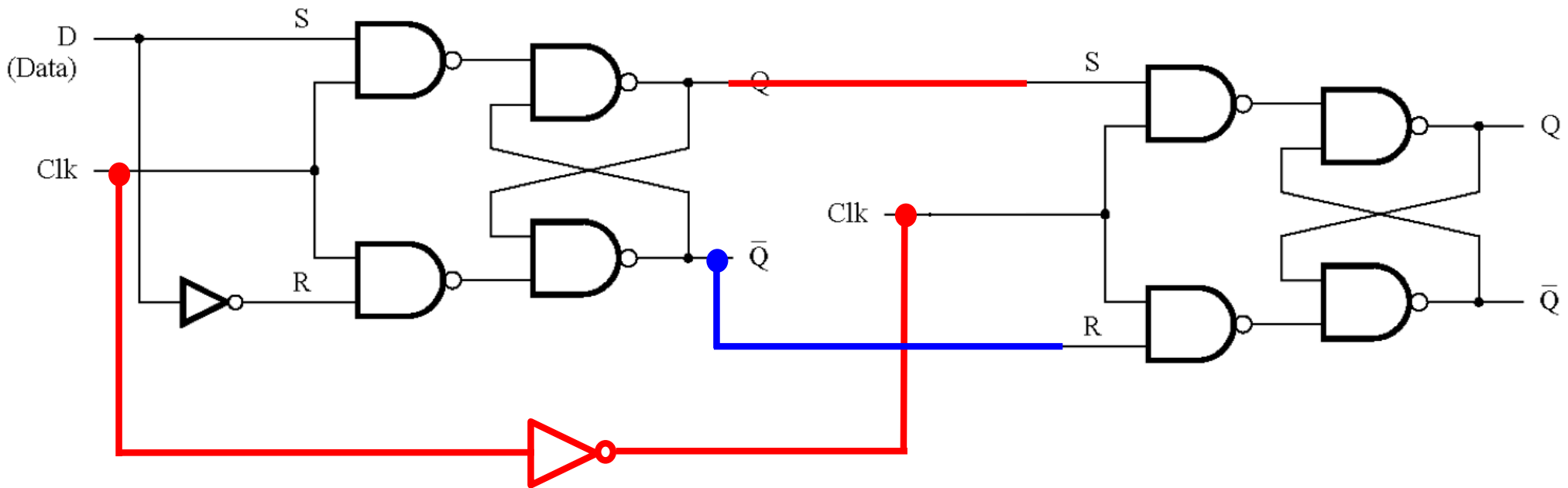

Edge-Triggered D Flip-Flops

Master-Slave D Flip-Flop

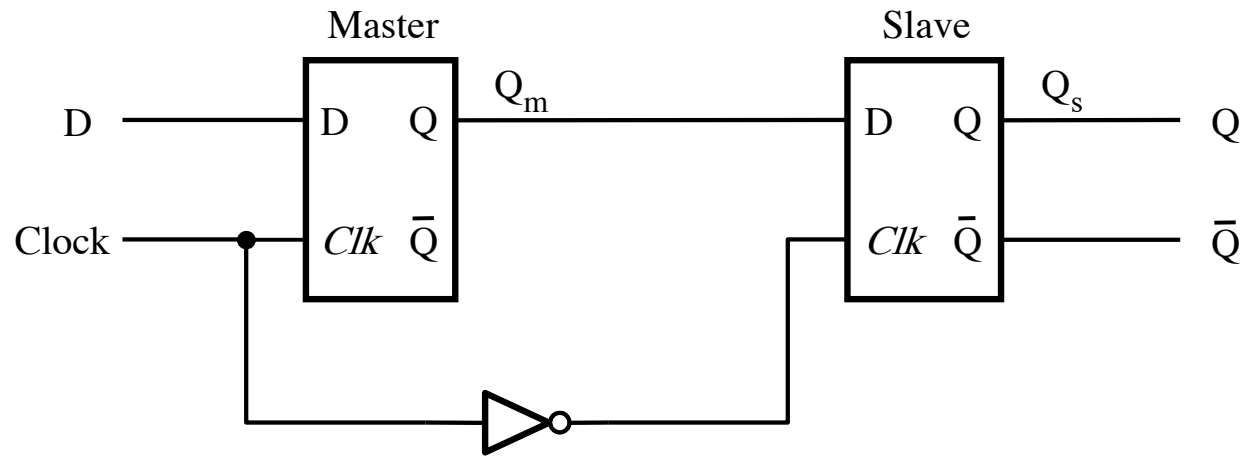

(a) Circuit

Negative-Edge-Triggered Master-Slave D Flip-Flop

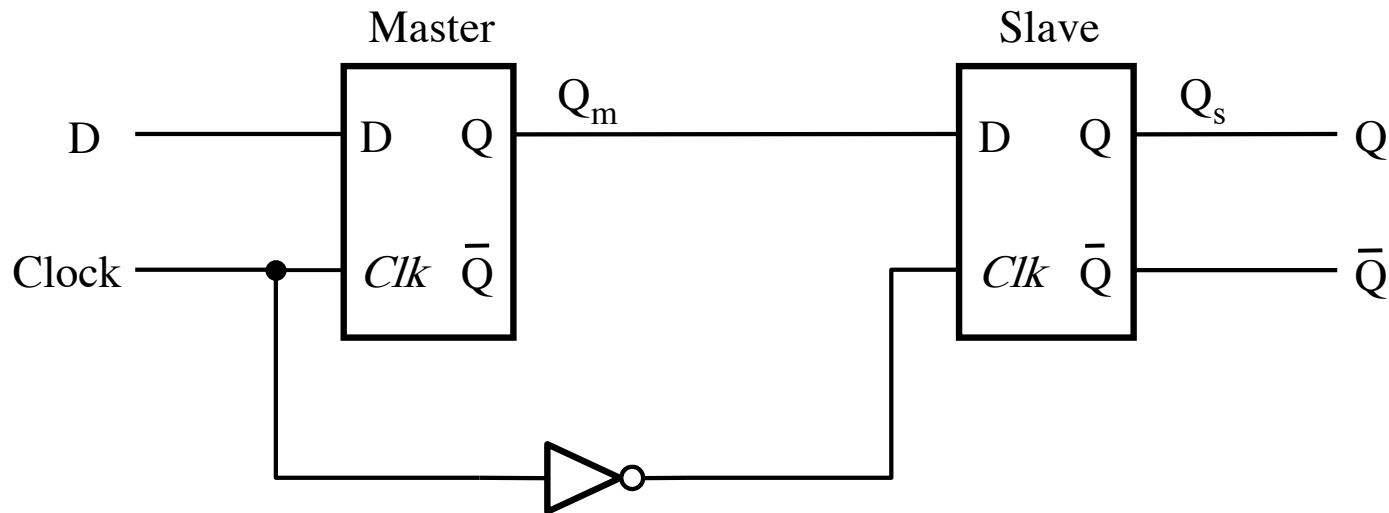

Positive-Edge-Triggered Master-Slave D Flip-Flop

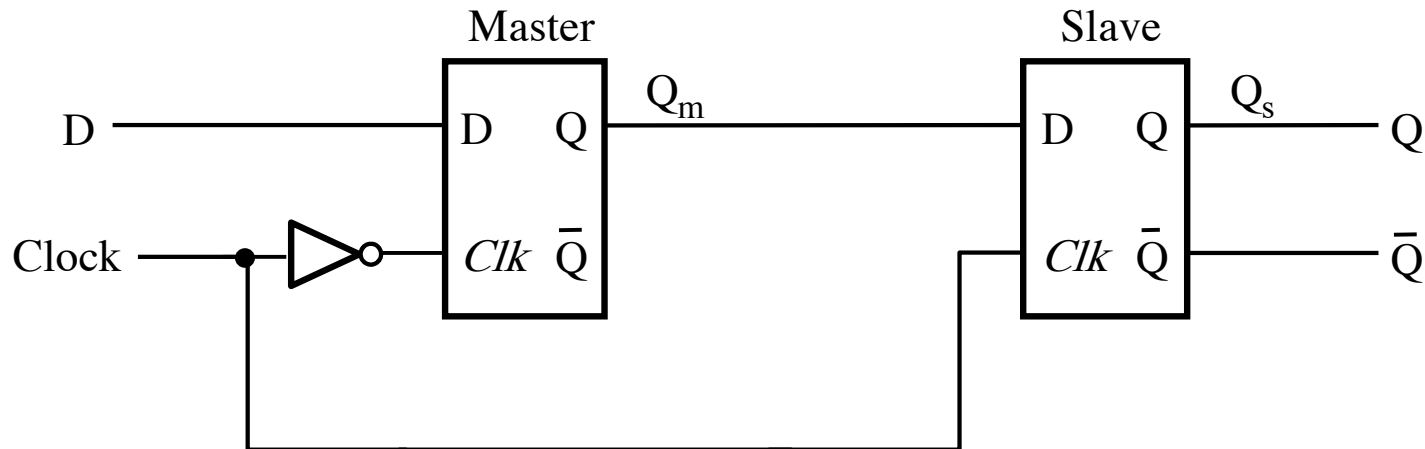

Negative-Edge-Triggered Master-Slave D Flip-Flop

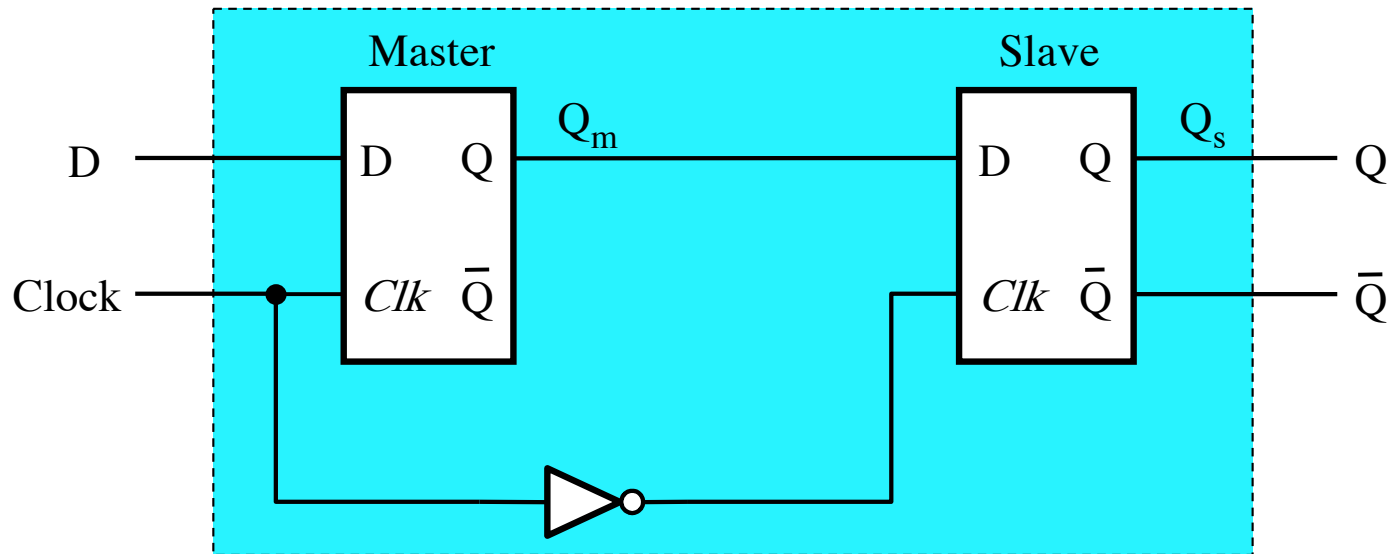

Positive-Edge-Triggered Master-Slave D Flip-Flop

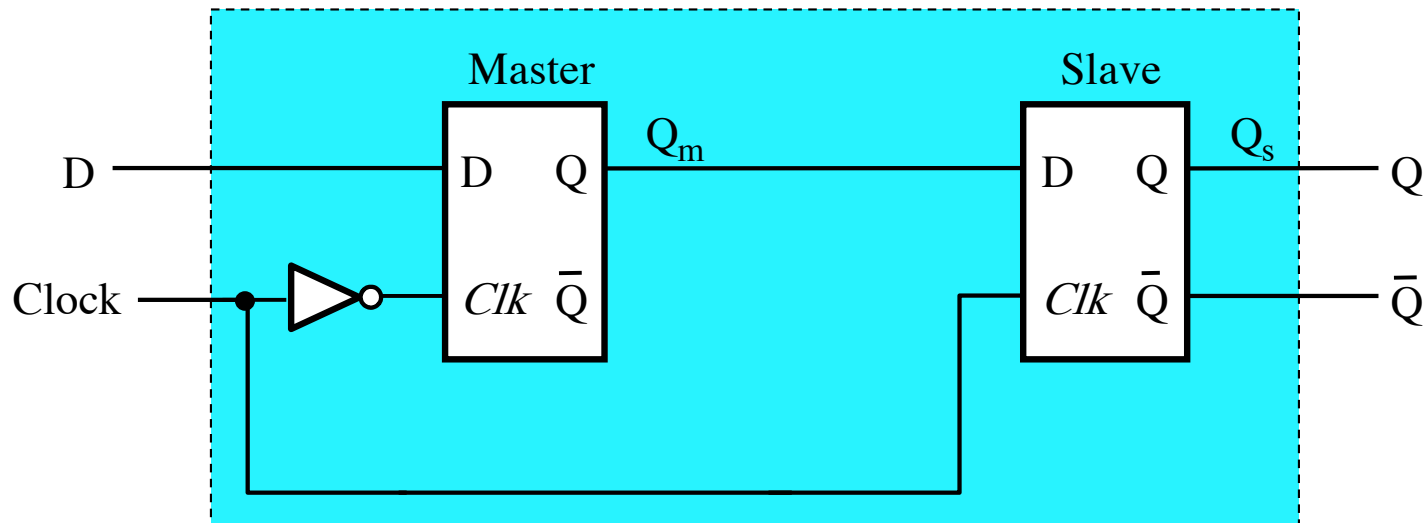

Negative-Edge-Triggered Master-Slave D Flip-Flop

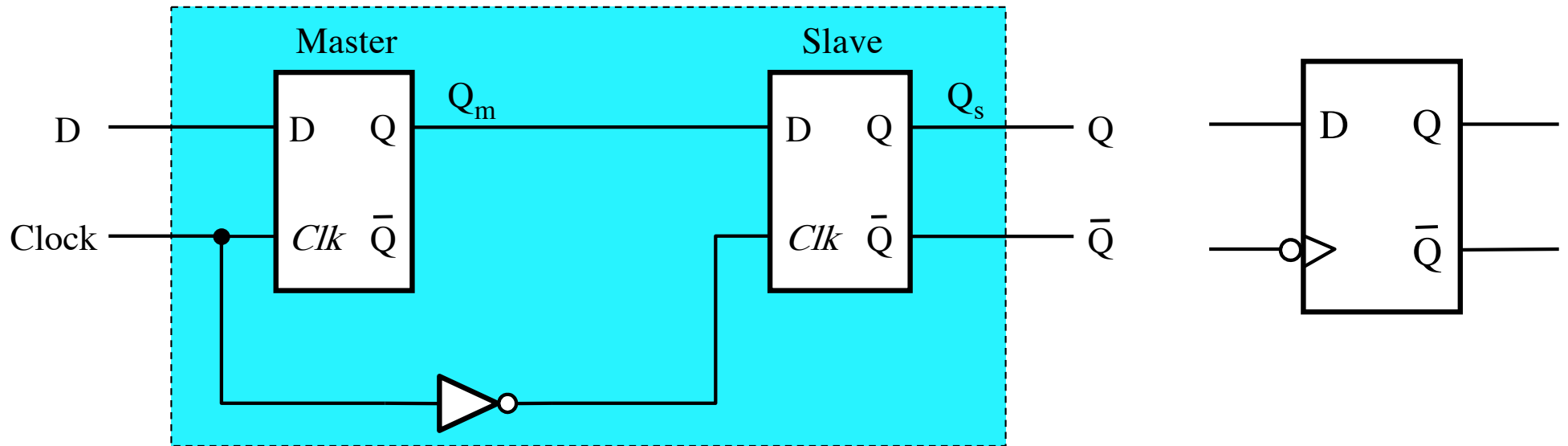

Positive-Edge-Triggered Master-Slave D Flip-Flop

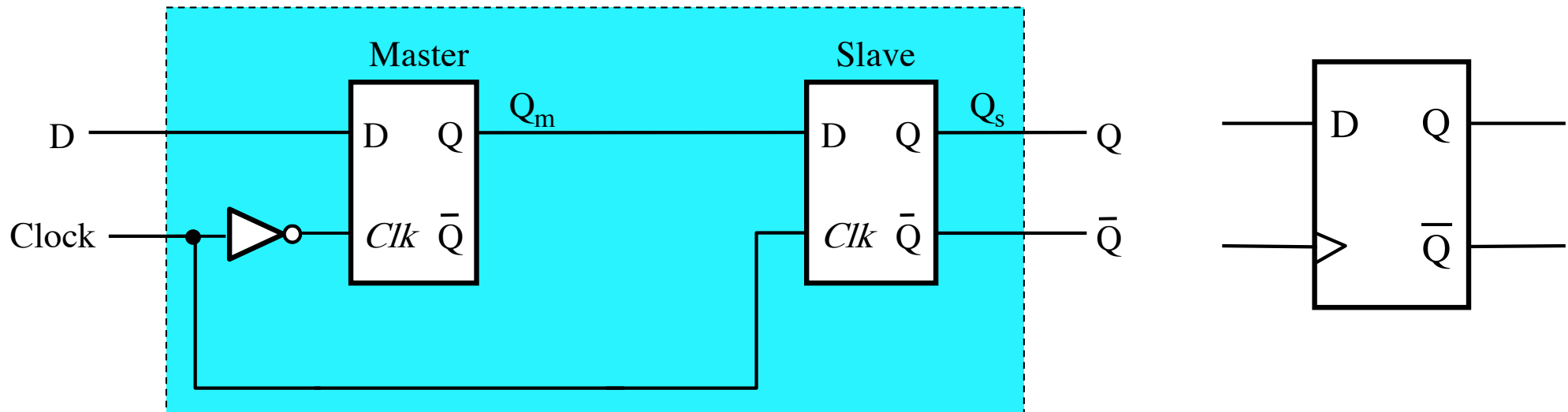

T Flip-Flop

T Flip-Flop

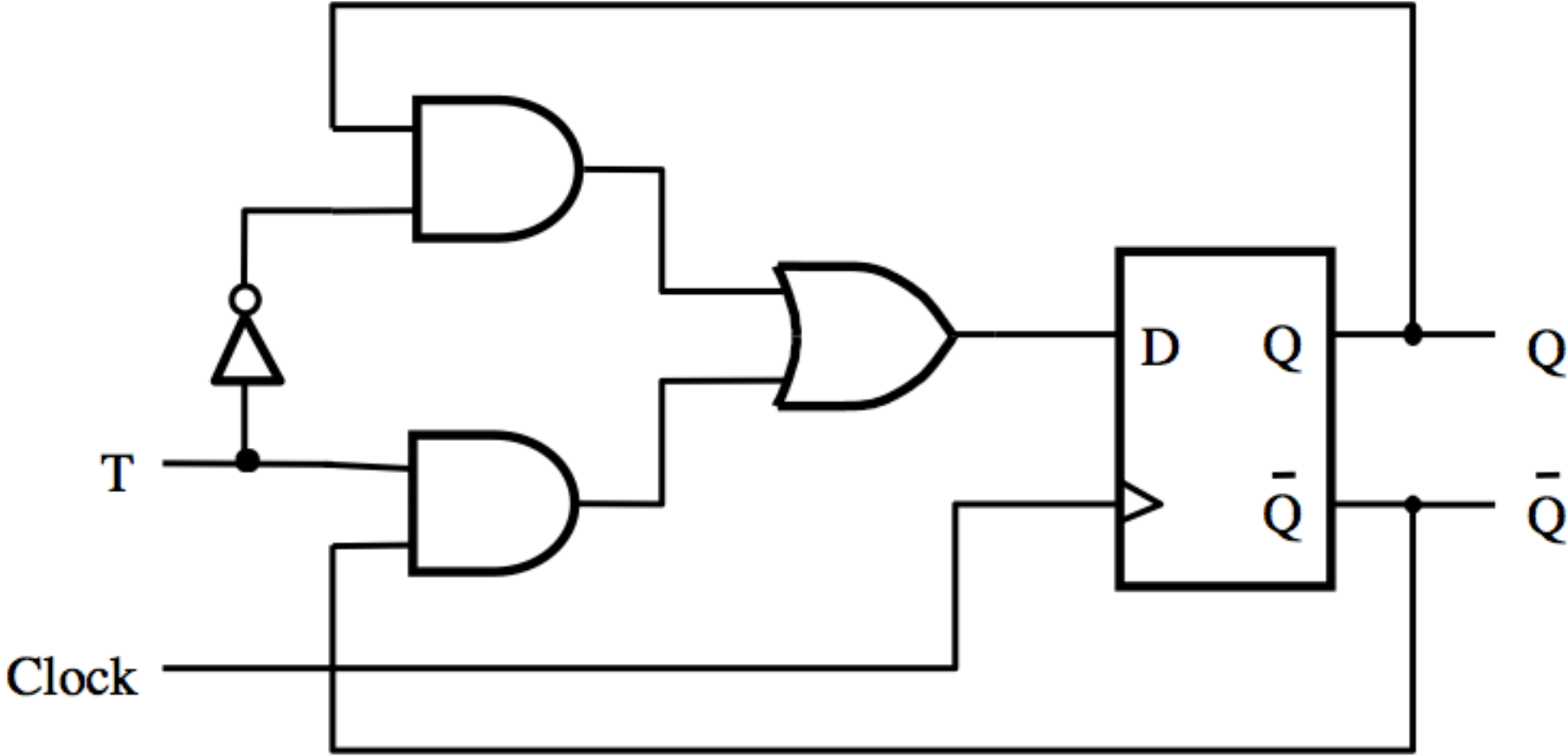

[Figure 5.15a from the textbook]

T Flip-Flop

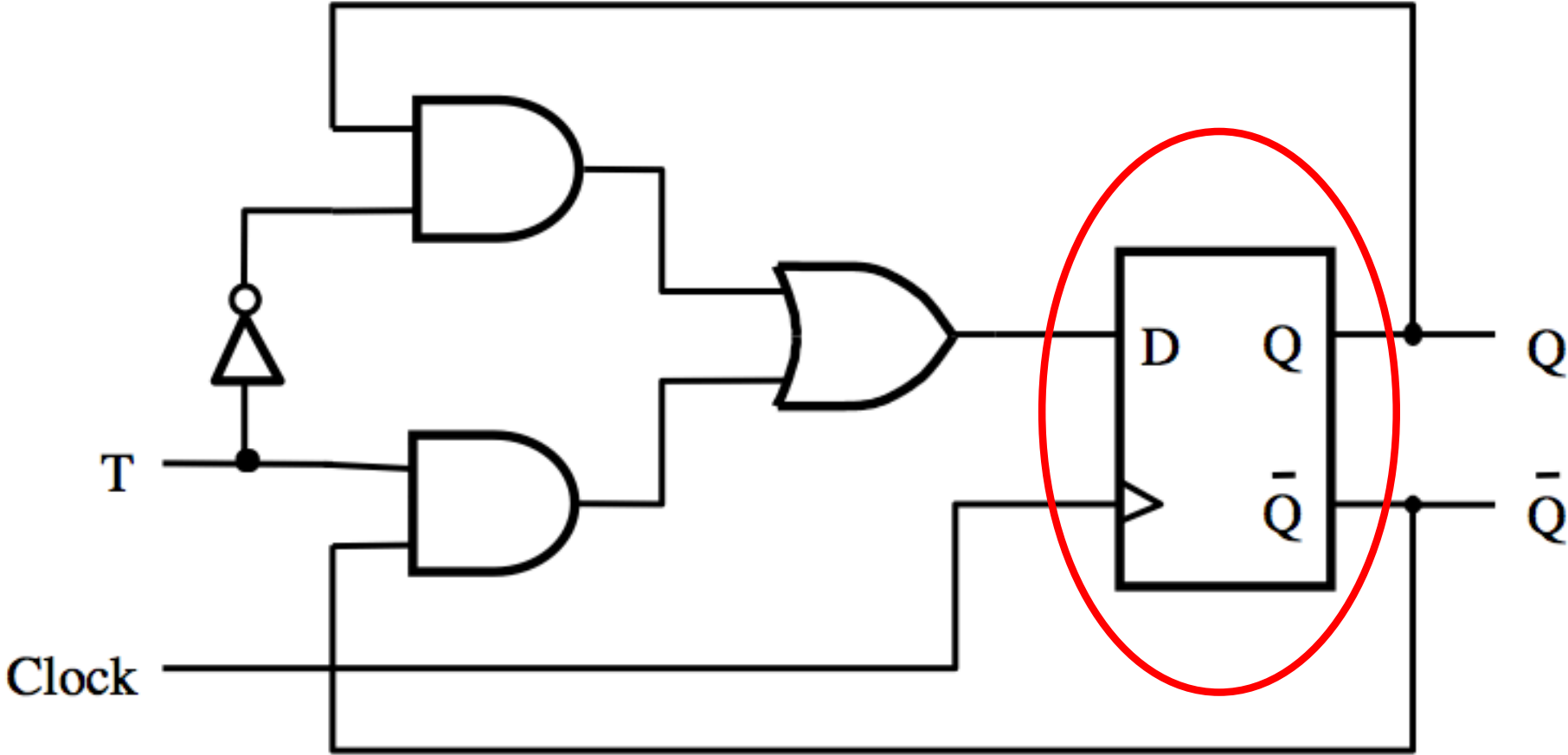

Positive-edge-triggered
D Flip-Flop

[Figure 5.15a from the textbook]

T Flip-Flop

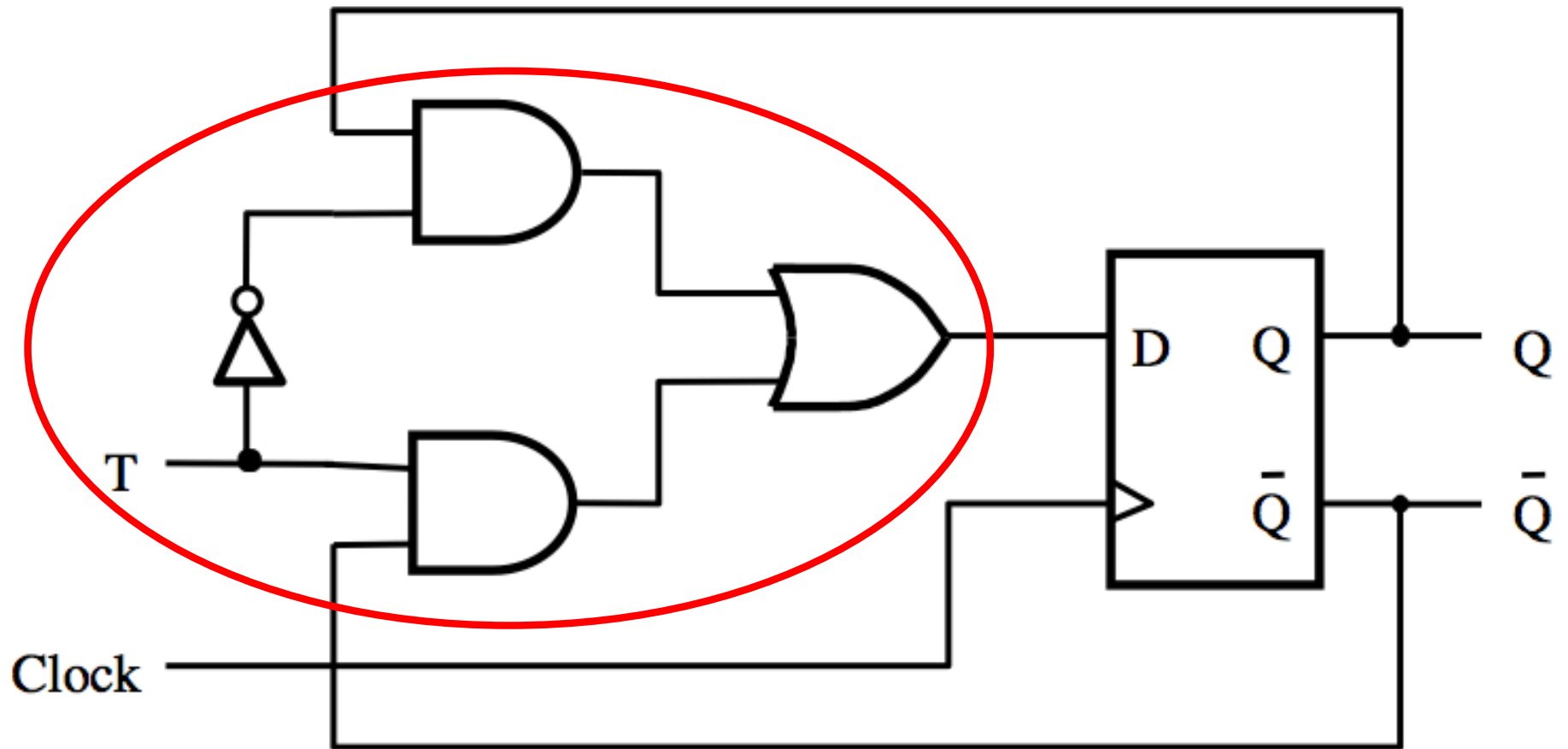

What is this?

What is this?

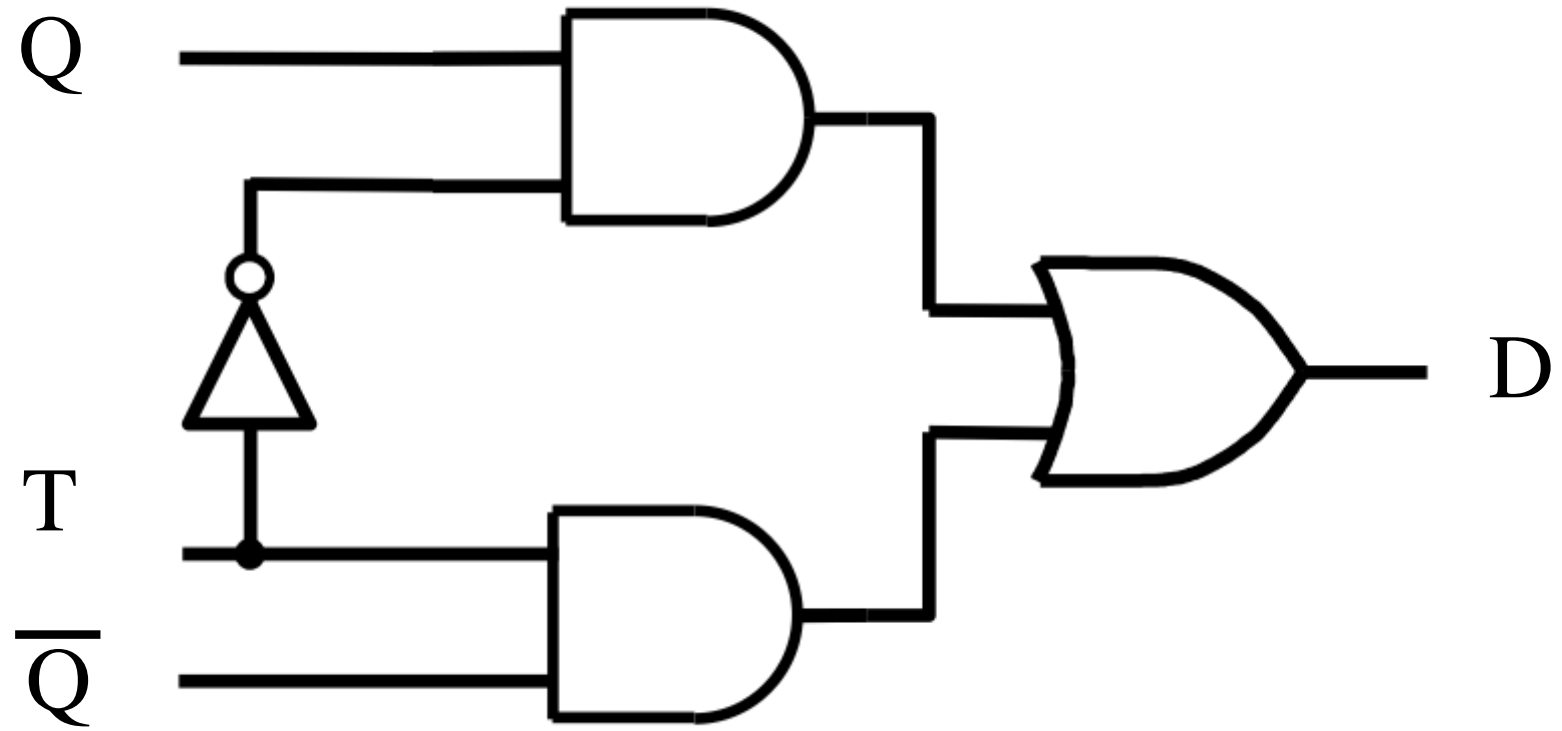

What is this?

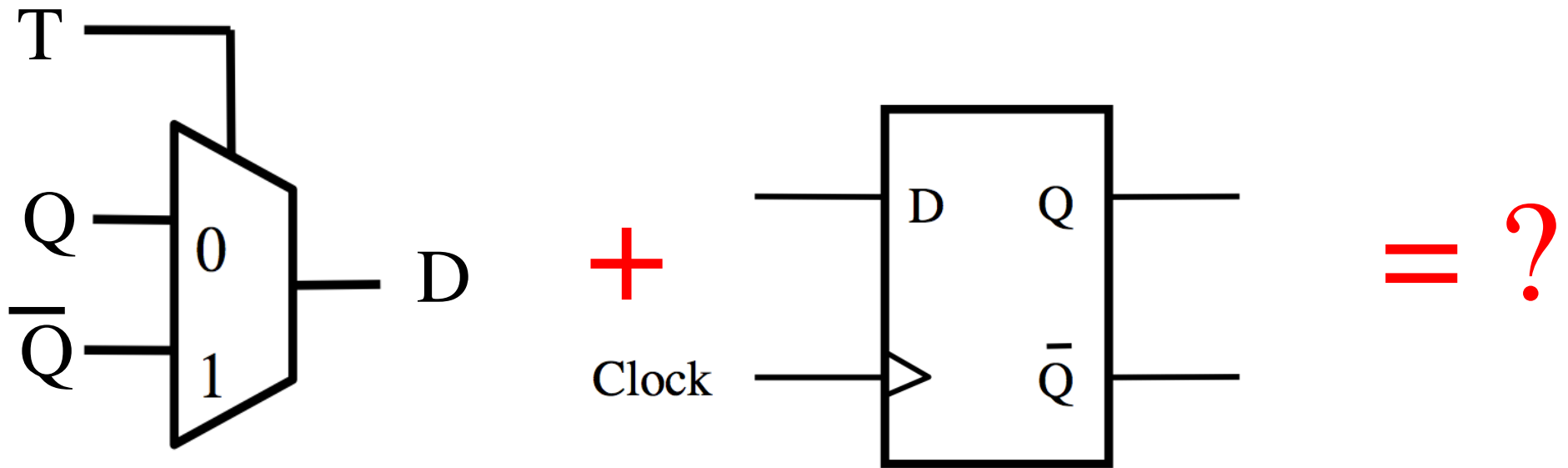

T Flip-Flop

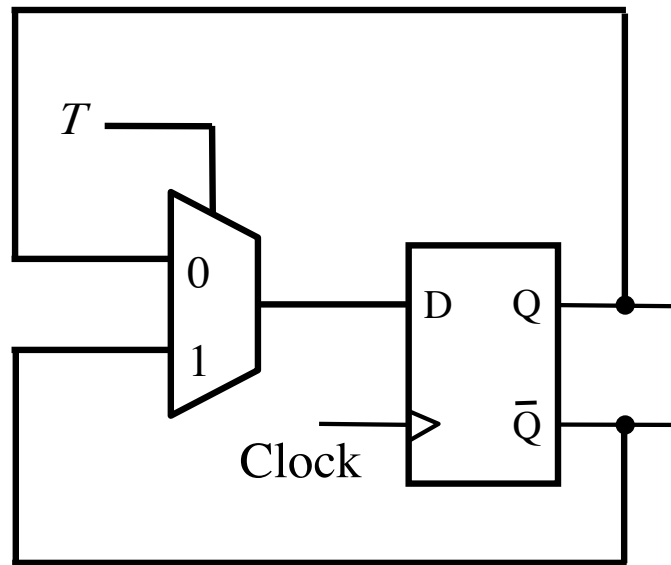

T Flip-Flop

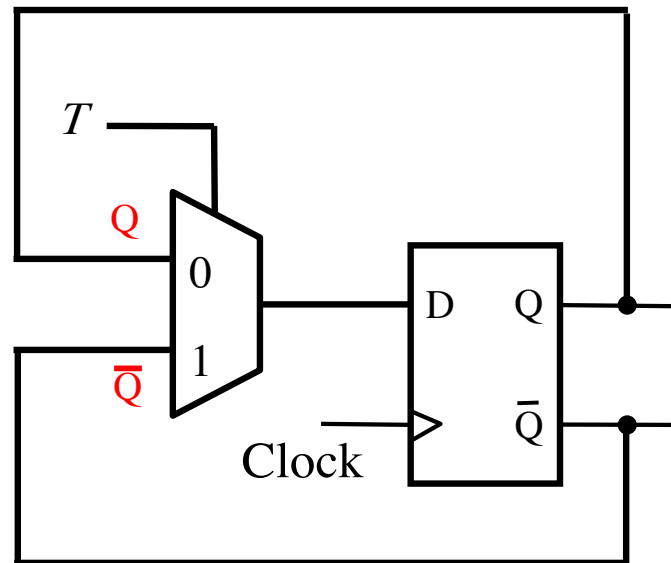

Note that the two inputs to the multiplexer are inverses of each other.

Another Way to Draw This

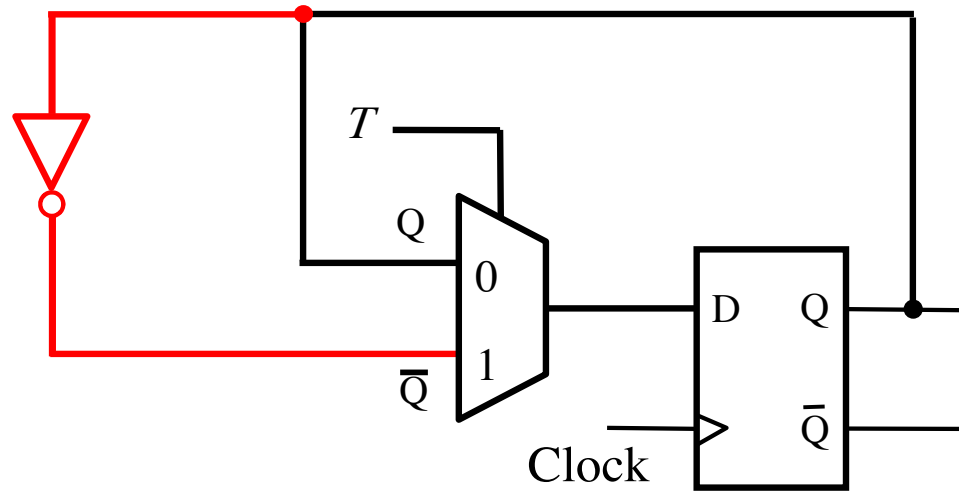

Another Way to Draw This

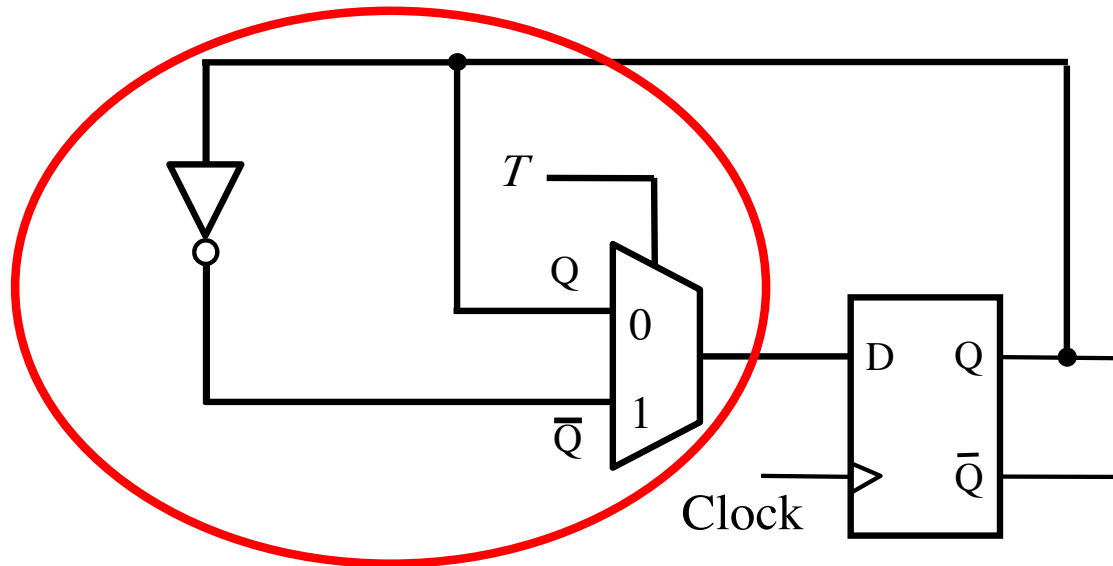

What is this?

What is this?

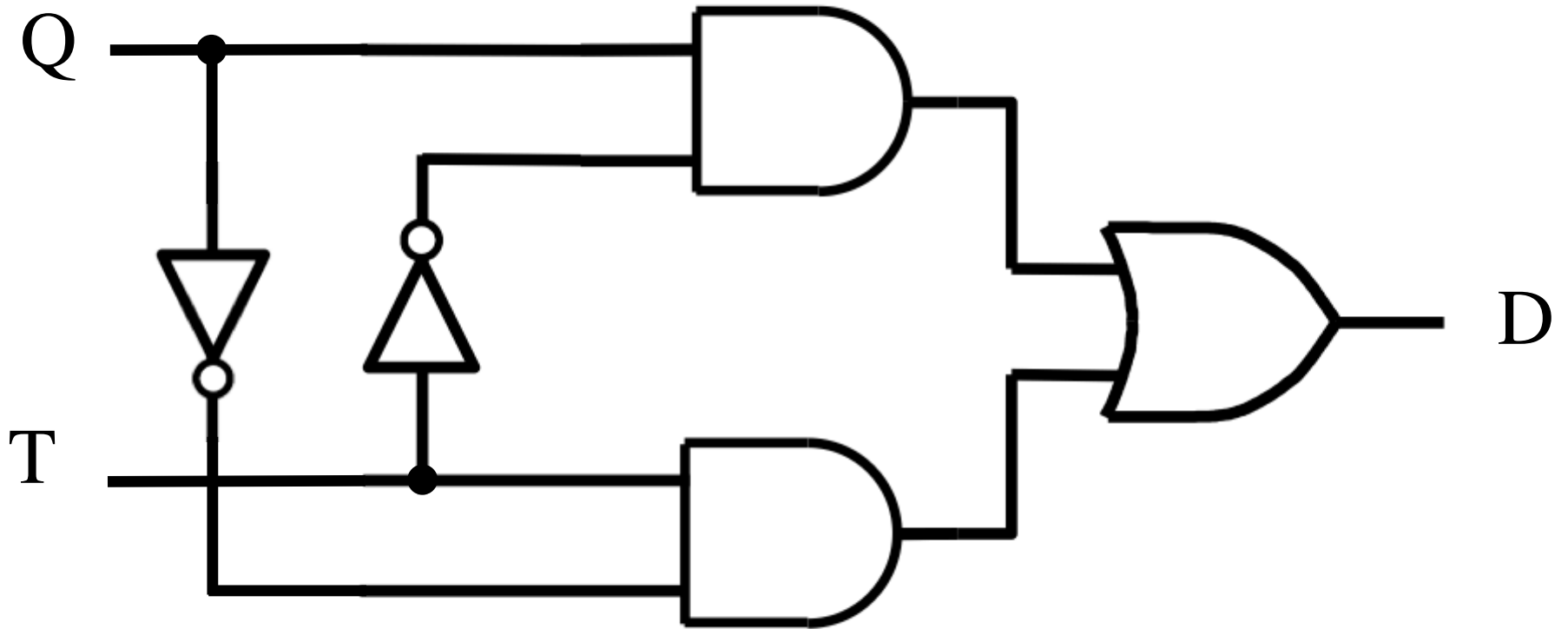

What is this?

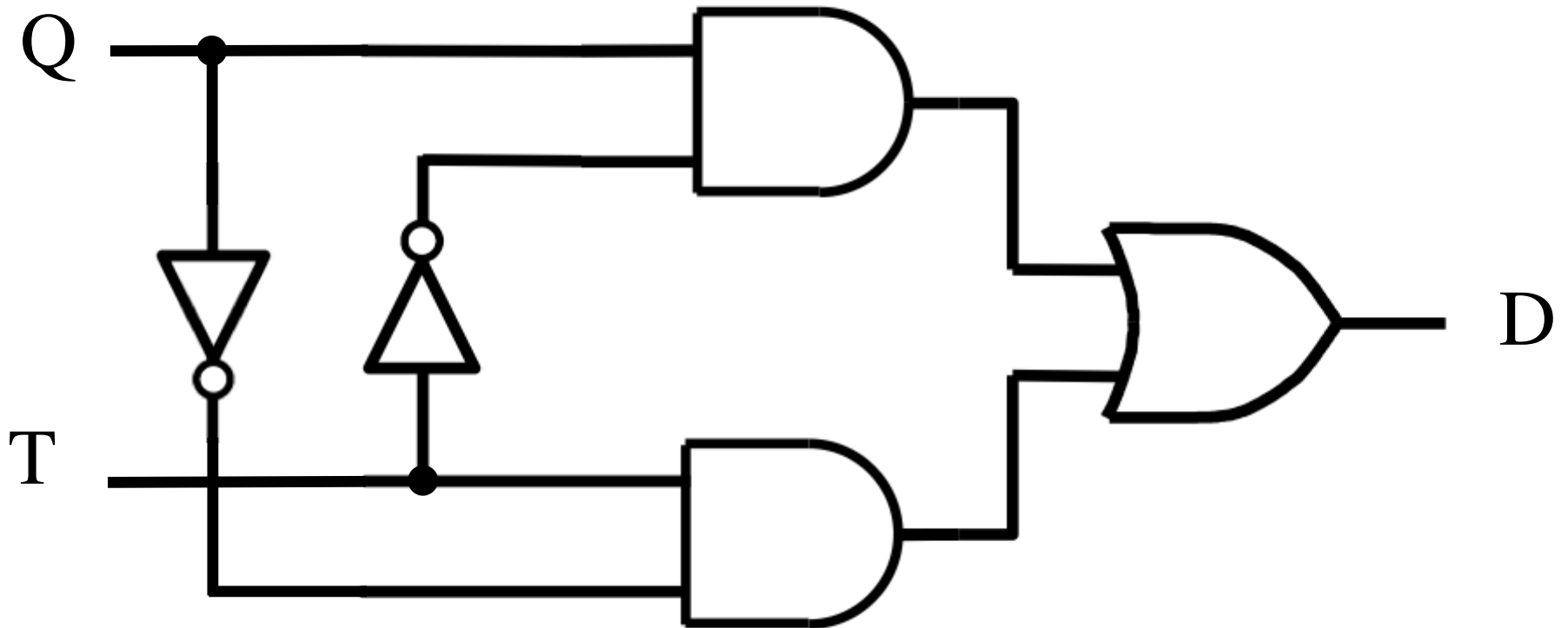

$$D = Q\bar{T} + \bar{Q}T$$

It is an XOR

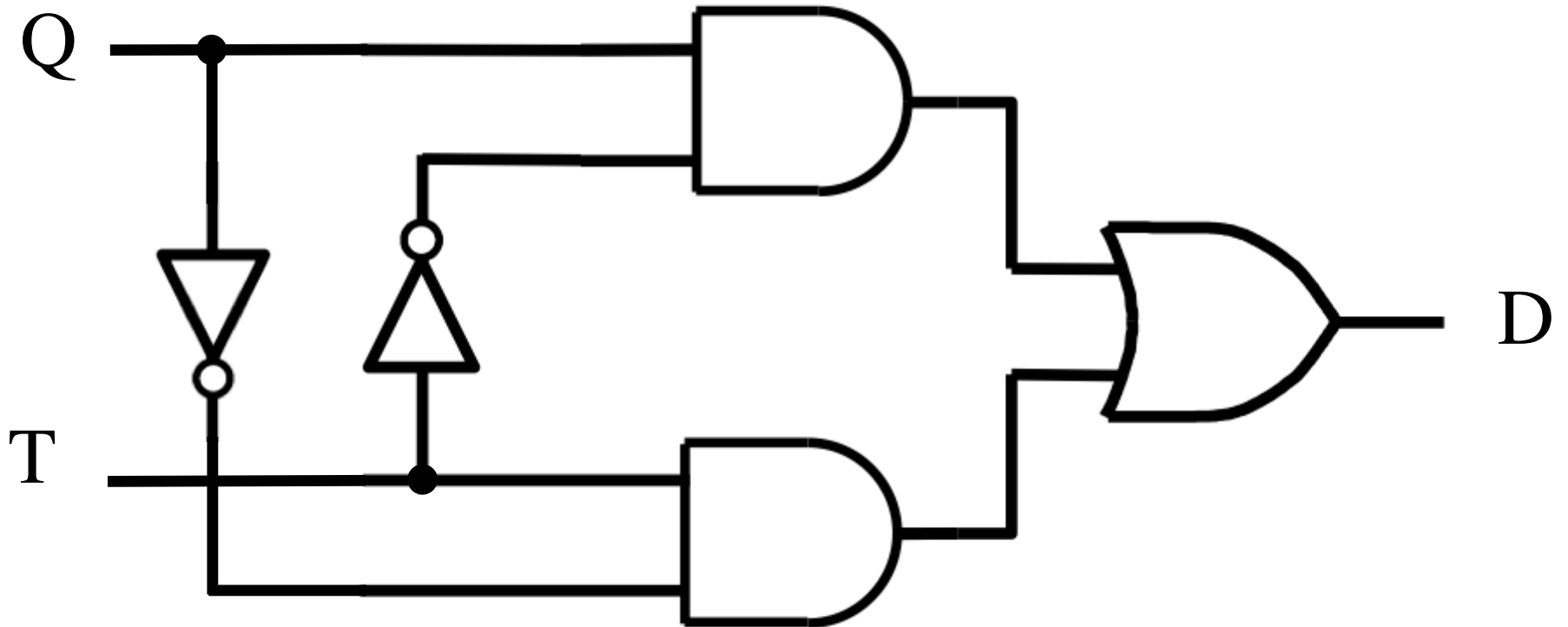

$$D = Q \oplus T$$

It is an XOR

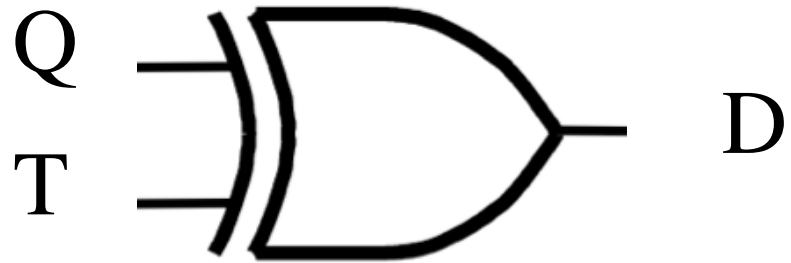

$$D = Q \oplus T$$

What is this?

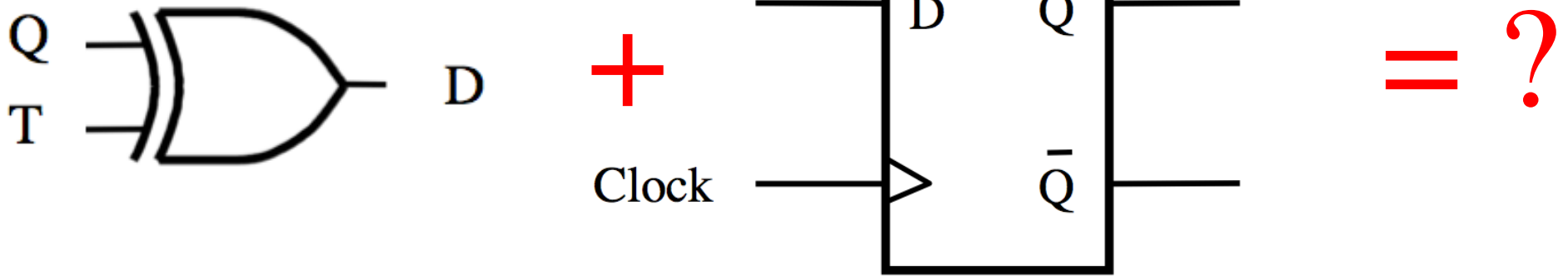

T Flip-Flop

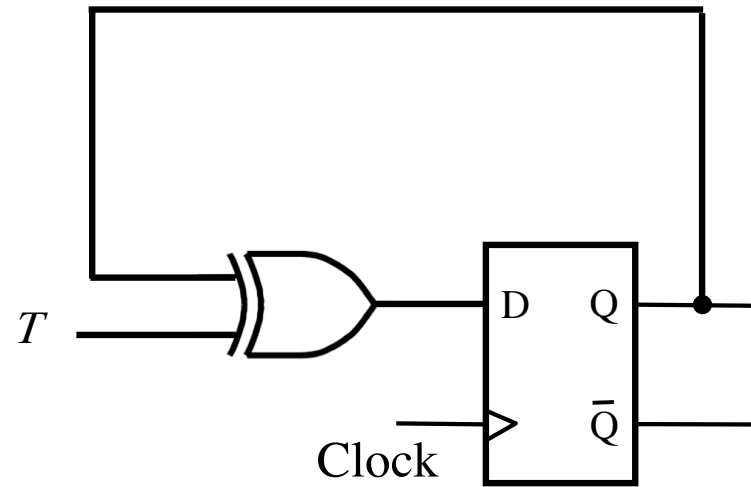

T Flip-Flop (circuit, truth table and graphical symbol)

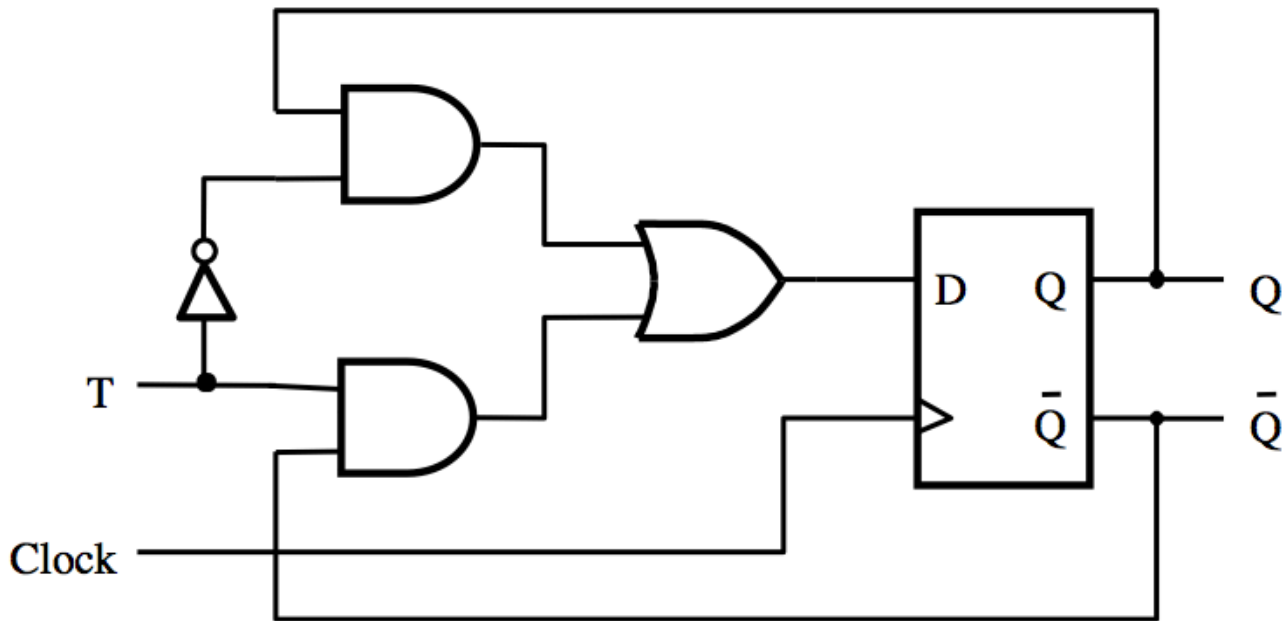

T	$Q(t+1)$
0	$Q(t)$
1	$\bar{Q}(t)$

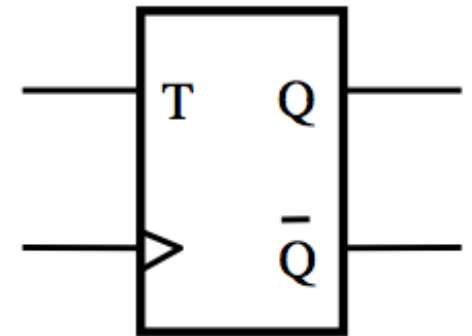

[Figure 5.15a-c from the textbook]

T Flip-Flop (How it Works)

If $T=0$ then it stays in its current state

If $T=1$ then it reverses its current state

In other words the circuit “toggles” its state when $T=1$. This is why it is called T flip-flop.

JK Flip-Flop

JK Flip-Flop

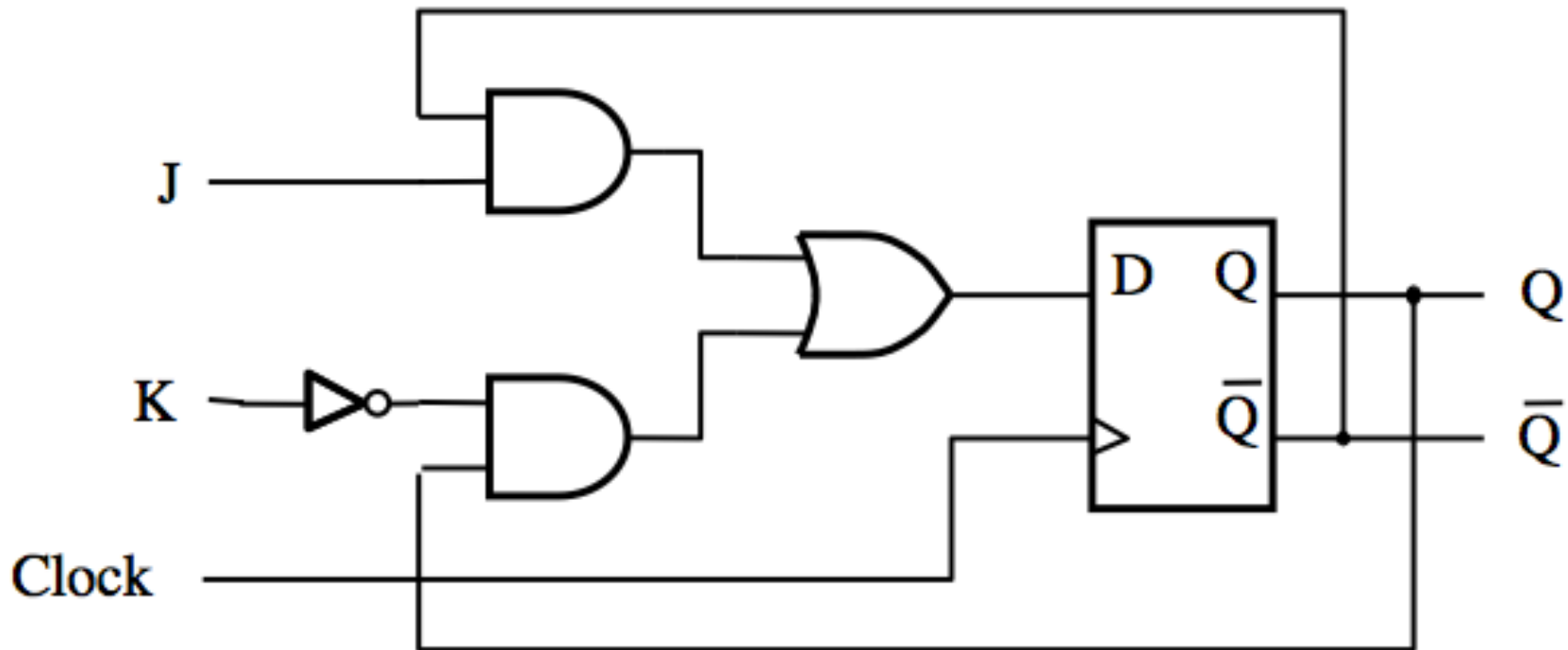

$$D = J\bar{Q} + \bar{K}Q$$

JK Flip-Flop

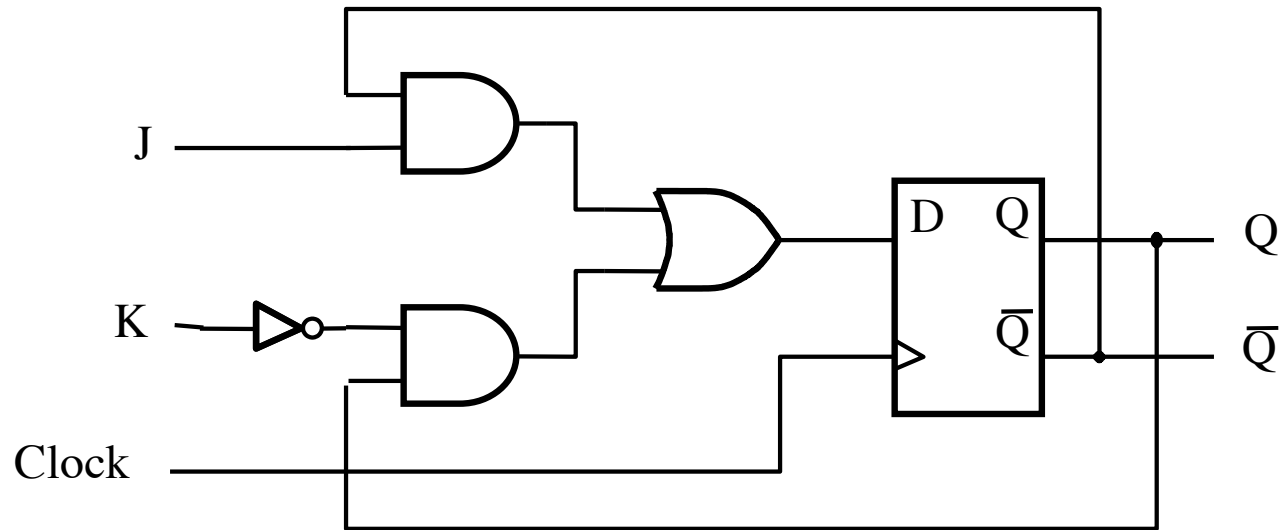

(a) Circuit

J	K	$Q(t+1)$
0	0	$Q(t)$
0	1	0
1	0	1
1	1	$\bar{Q}(t)$

(b) Truth table

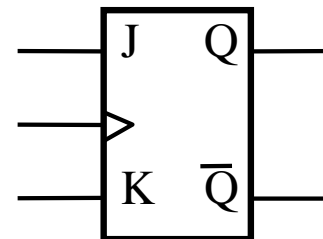

(c) Graphical symbol

JK Flip-Flop (How it Works)

**A versatile circuit that can be used both as a
SR flip-flop and as a T flip flop**

If $J=0$ and $S =0$ it stays in the same state

Just like SR It can be set and reset

$J=S$ and $K=R$

If $J=K=1$ then it behaves as a T flip-flop

Complete Wiring Diagrams

Positive-Edge-Triggered D Flip-Flop

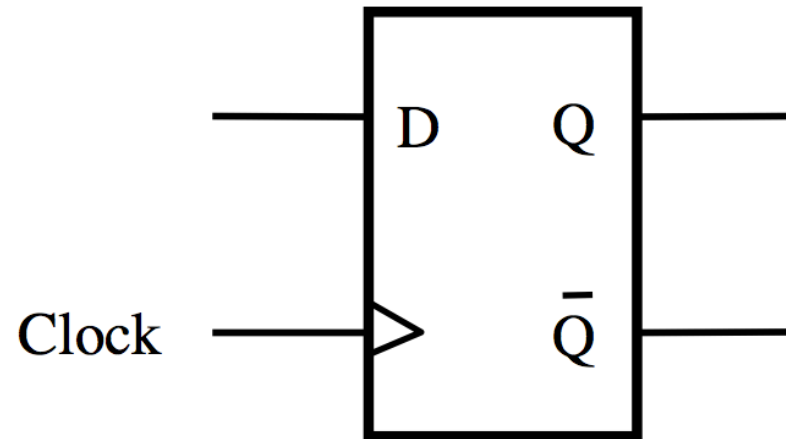

Negative-Edge-Triggered D Flip-Flop

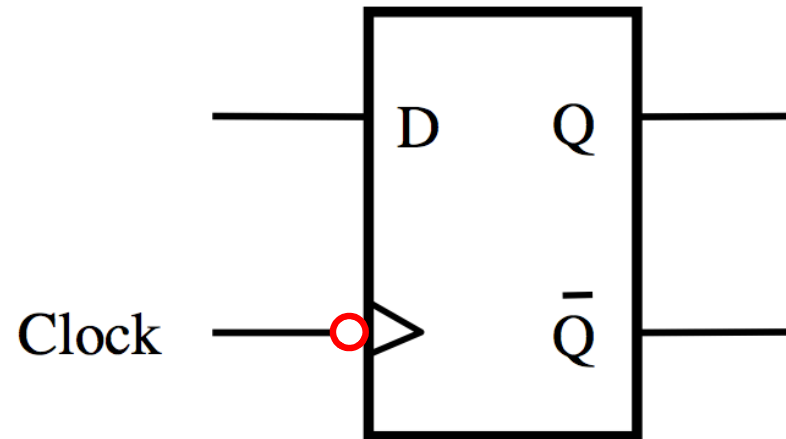

The Complete Wiring Diagram for a Positive-Edge-Triggered D Flip-Flop

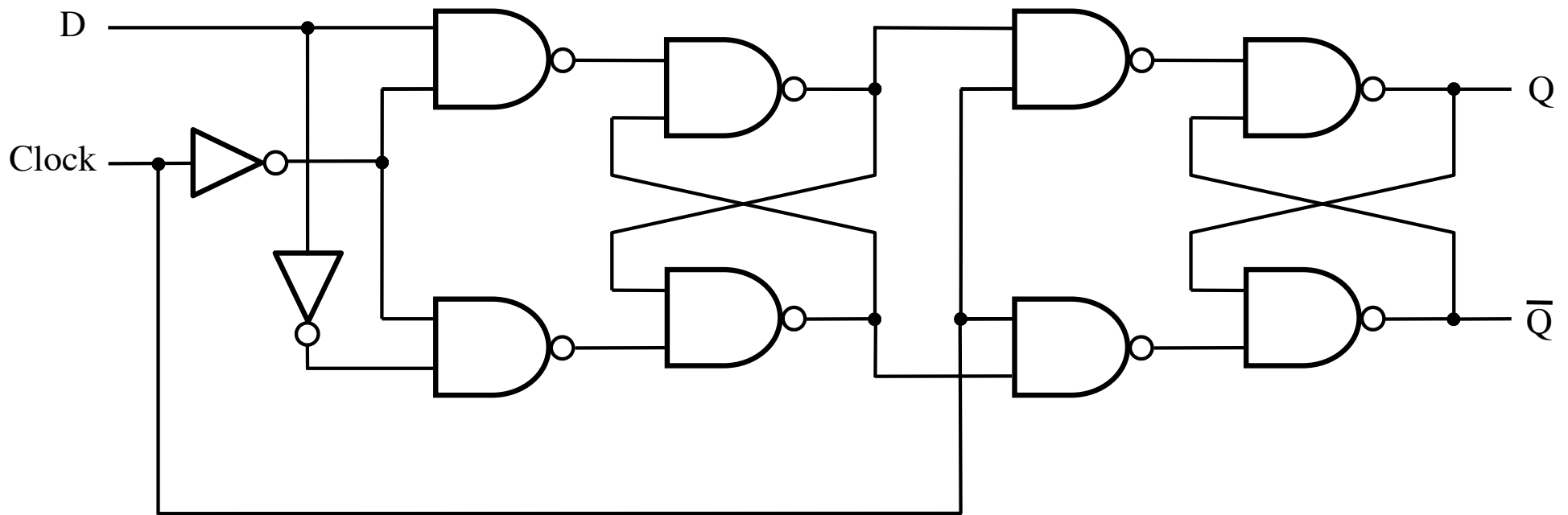

The Complete Wiring Diagram for a **Negative**-Edge-Triggered D Flip-Flop

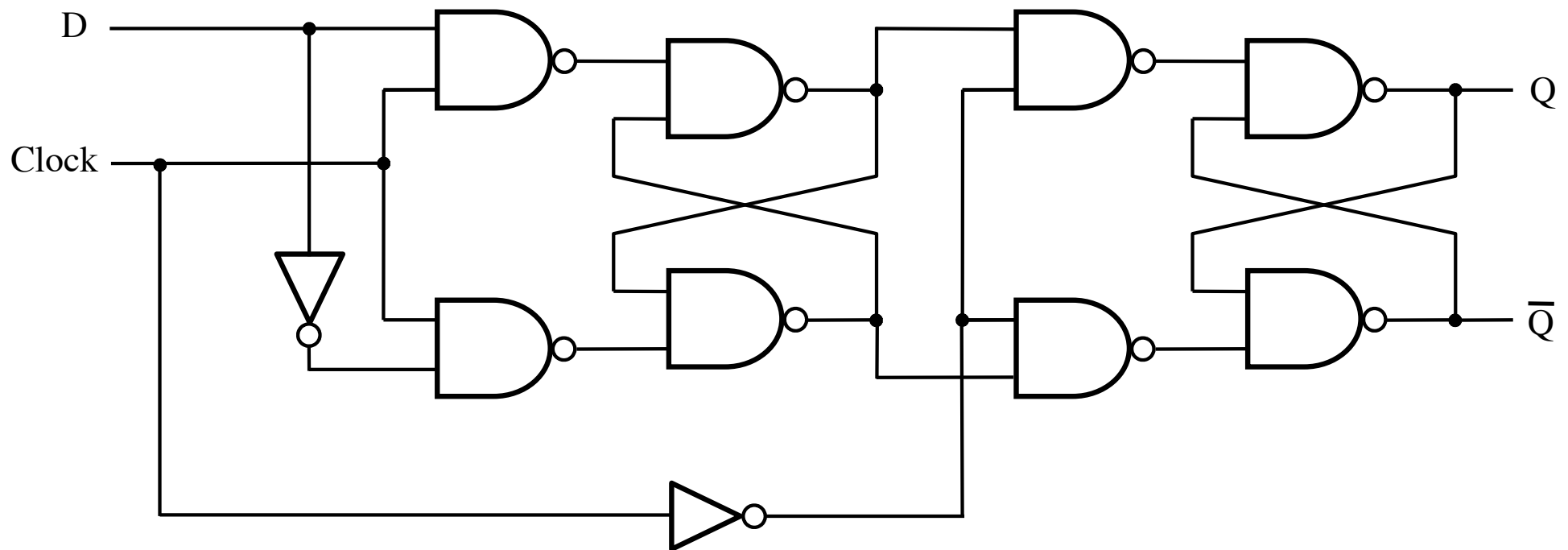

The Complete Wiring Diagram for a **Negative**-Edge-Triggered D Flip-Flop

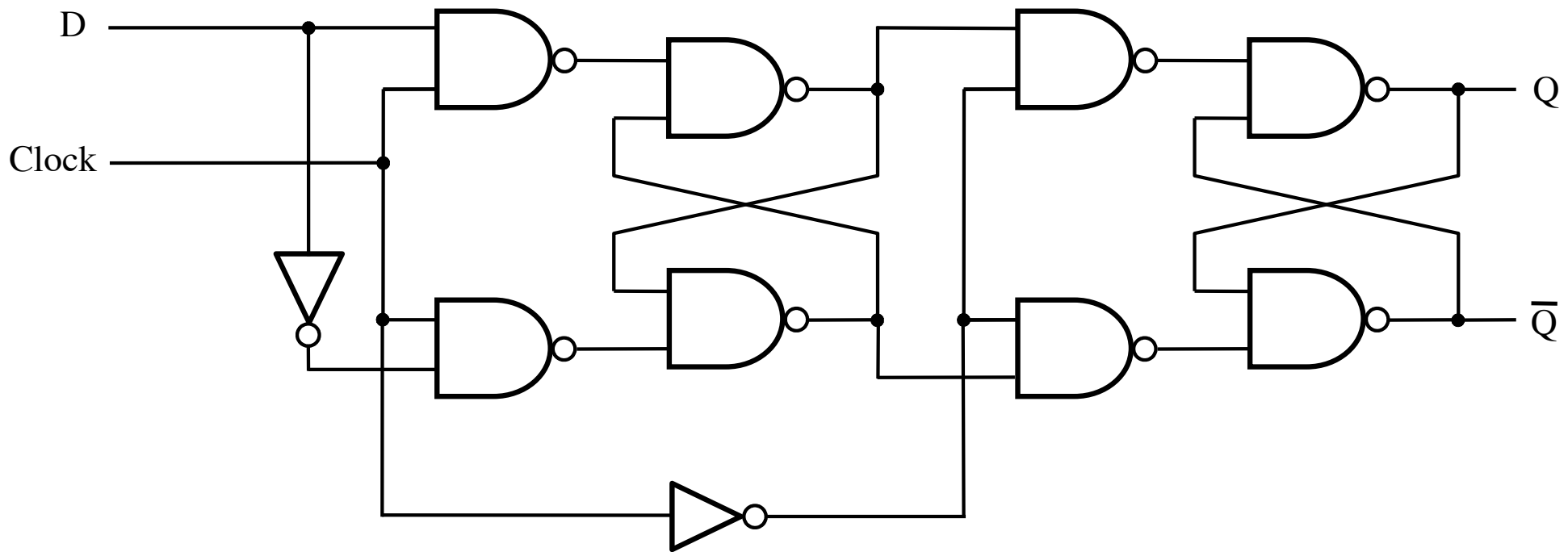

Positive-Edge-Triggered T Flip-Flop

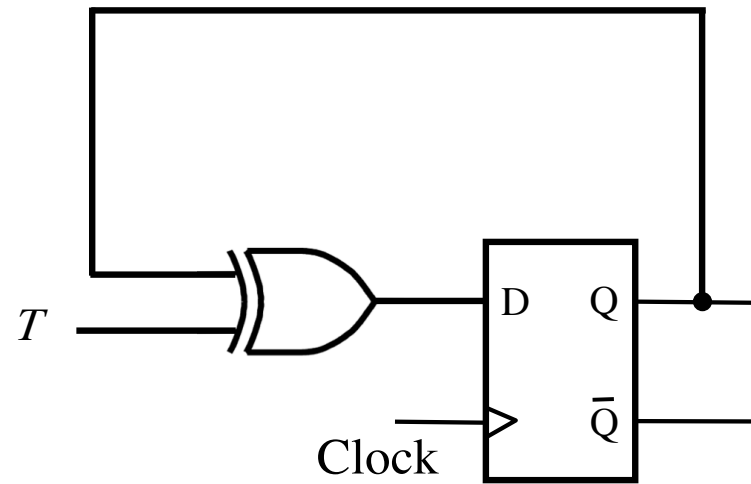

Negative-Edge-Triggered T Flip-Flop

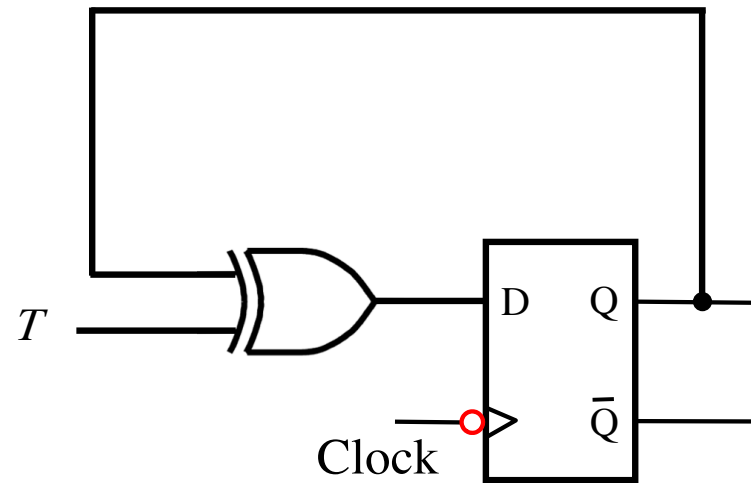

The Complete Wiring Diagram for a Positive-Edge-Triggered D Flip-Flop

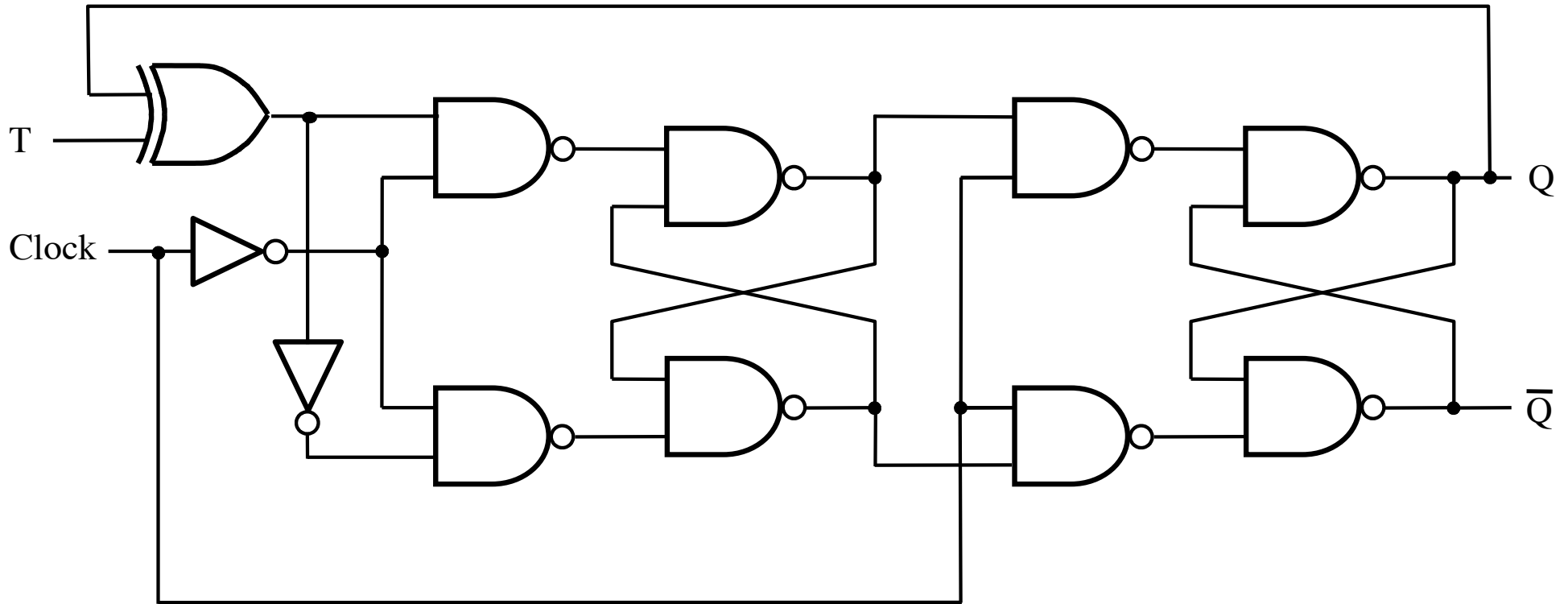

Positive-Edge-Triggered JK Flip-Flop

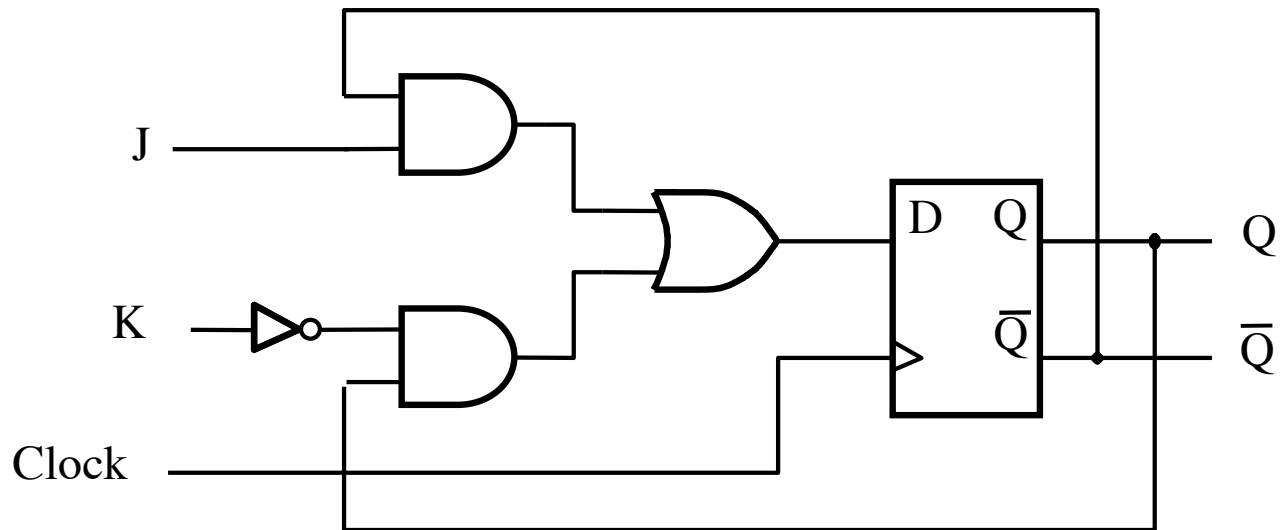

Negative-Edge-Triggered JK Flip-Flop

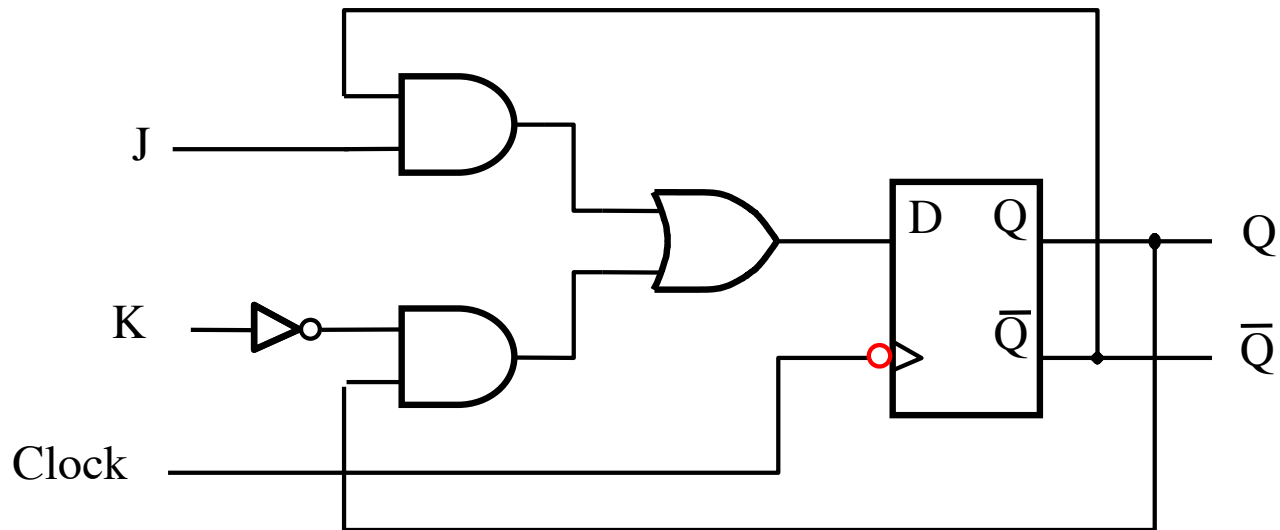

The Complete Wiring Diagram for a Positive-Edge-Triggered JK Flip-Flop

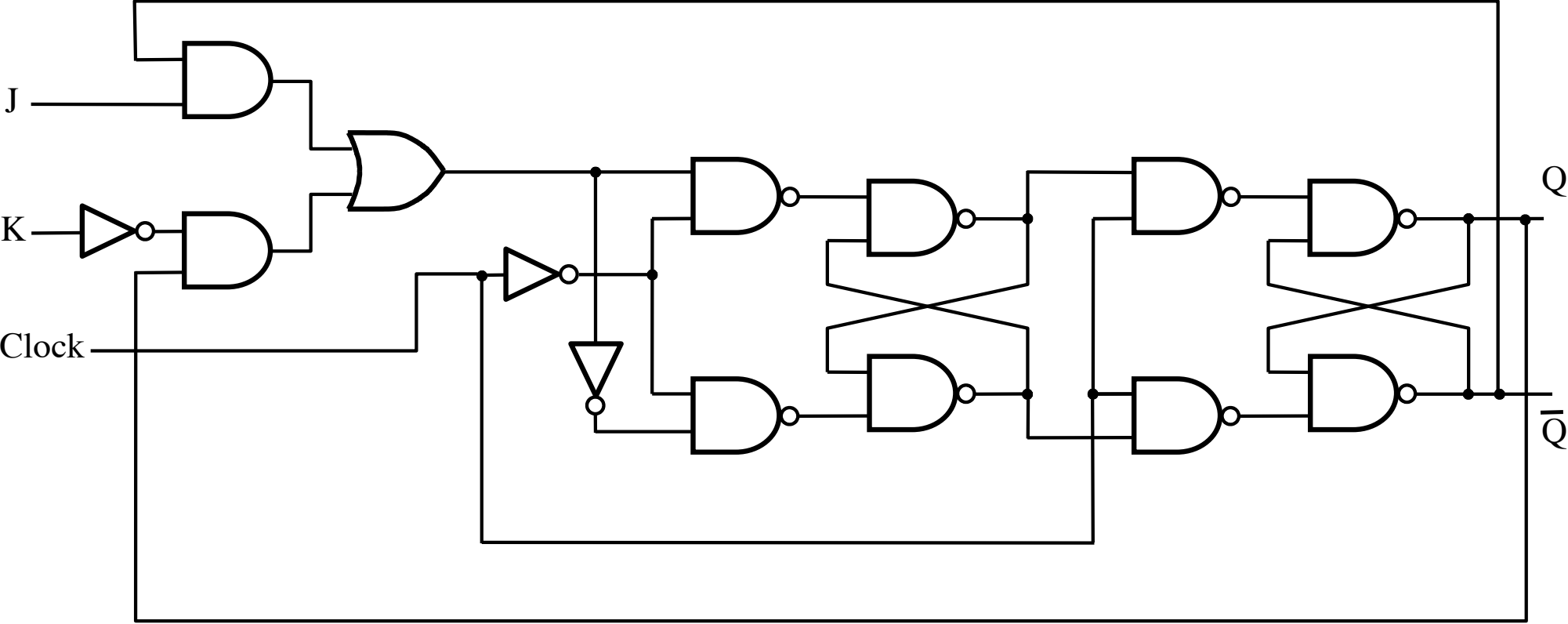

The Complete Wiring Diagram for a **Negative**-Edge-Triggered JK Flip-Flop

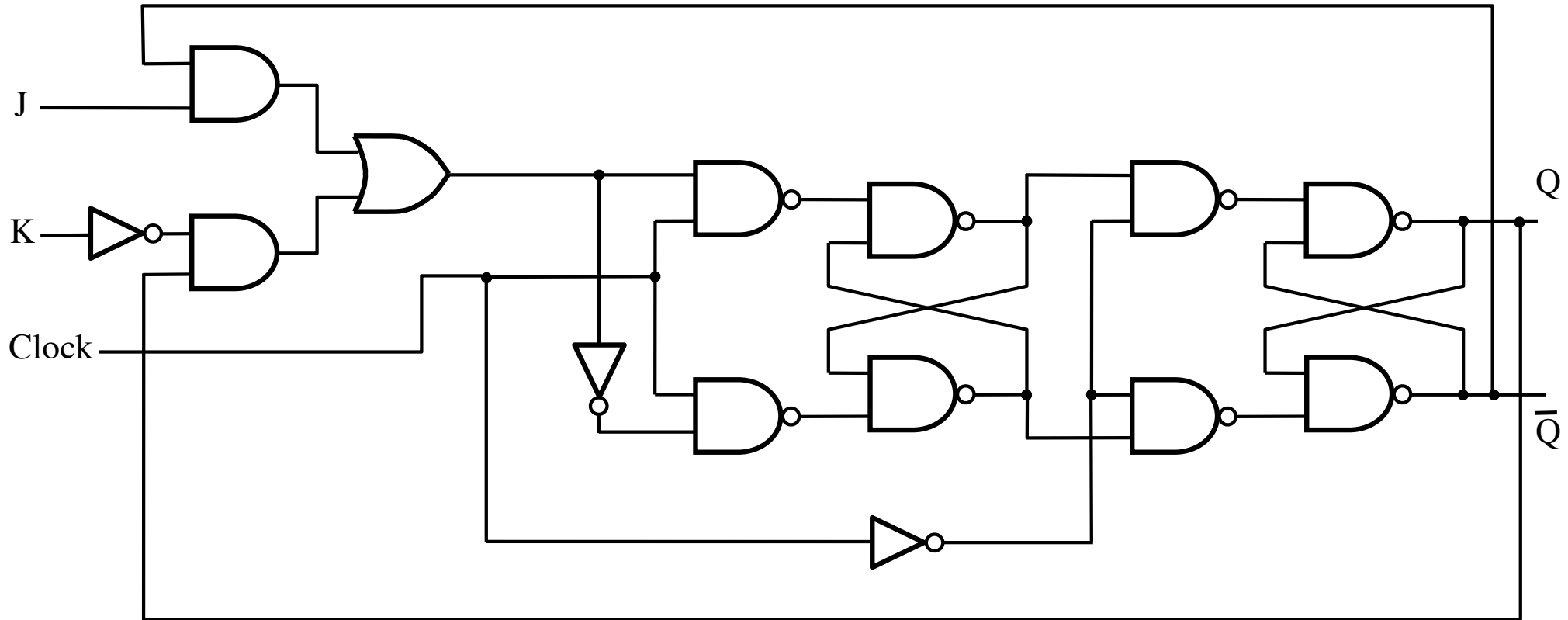

Registers

Register (Definition)

An n-bit structure consisting of flip-flops.

Parallel-Access Register

1-Bit Parallel-Access Register

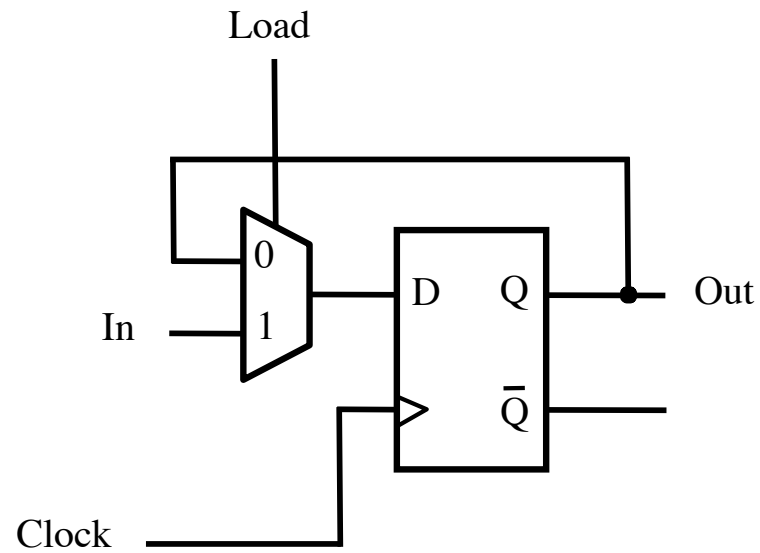

1-Bit Parallel-Access Register

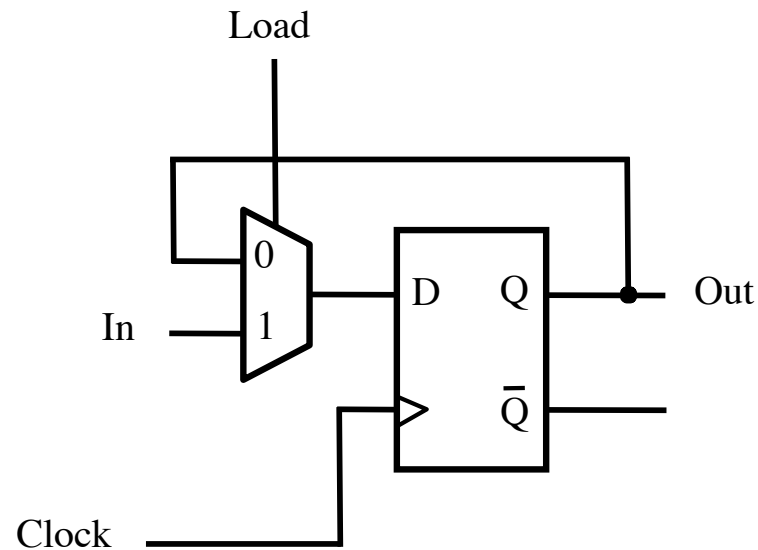

The 2-to-1 multiplexer is used to select whether to load a new value into the D flip-flop or to retain the old value.

The output of this circuit is the Q output of the flip-flop.

1-Bit Parallel-Access Register

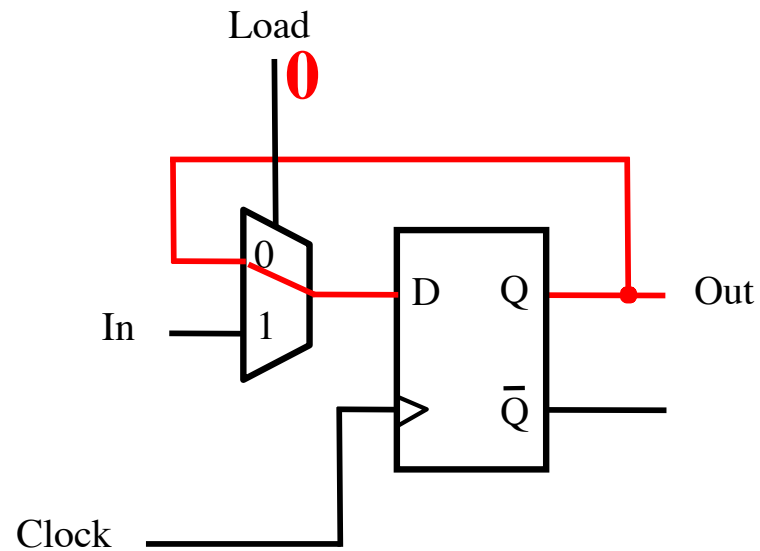

If Load = 0, then retain the old value.

1-Bit Parallel-Access Register

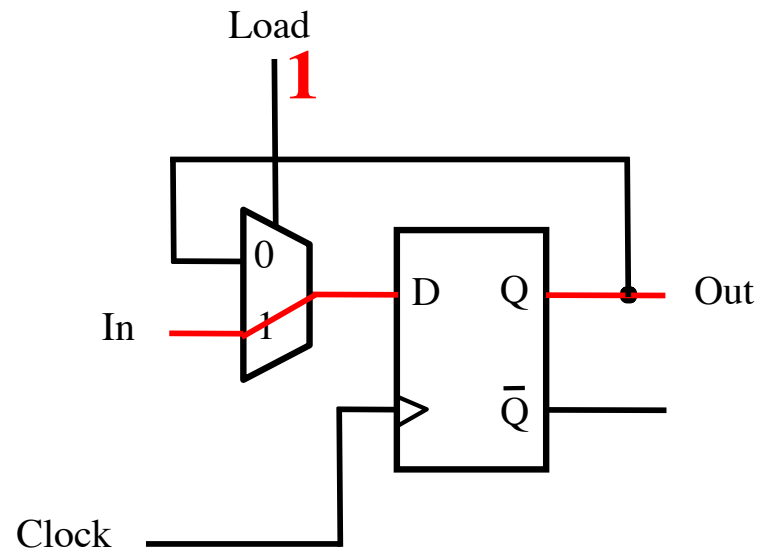

If Load = 1, then load the new value from In.

1-Bit Parallel-Access Register

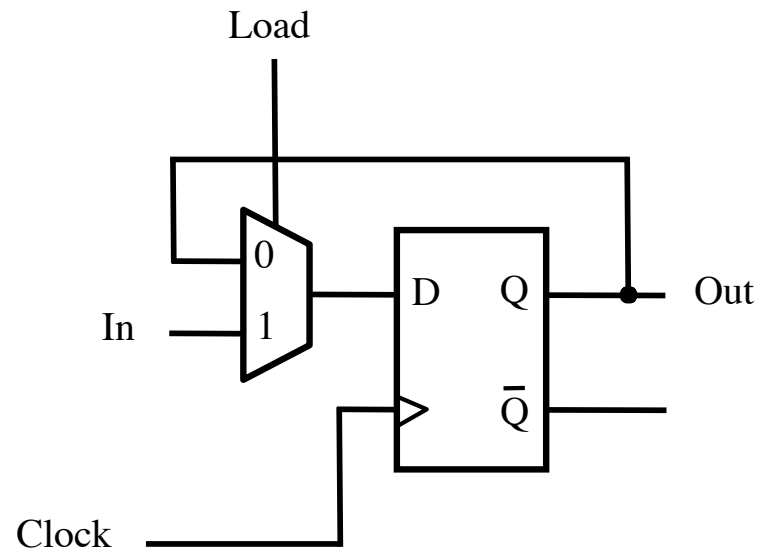

If Load = 0, then retain the old value.

If Load = 1, then load the new value from In.

2-Bit Parallel-Access Register

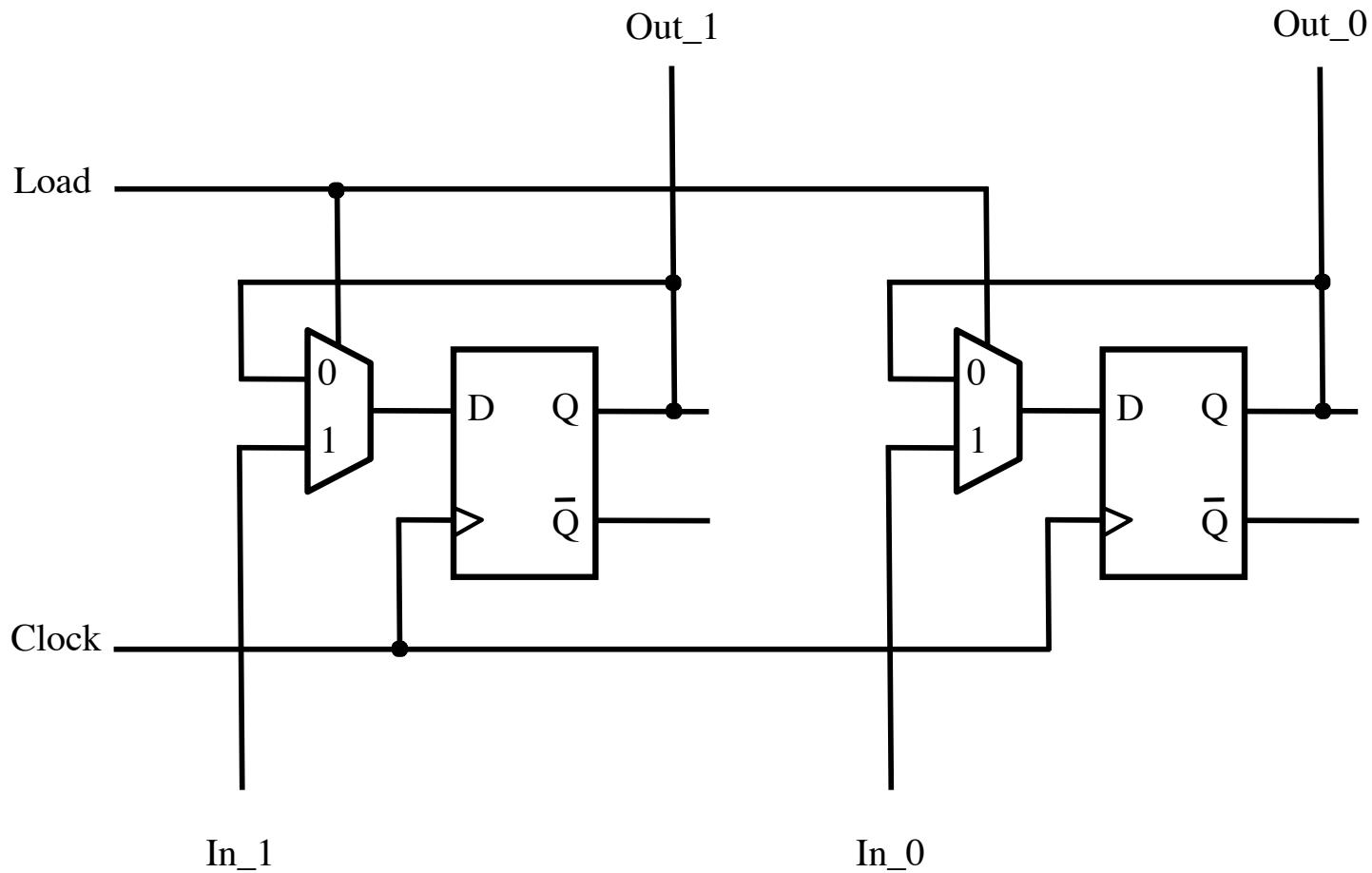

2-Bit Parallel-Access Register

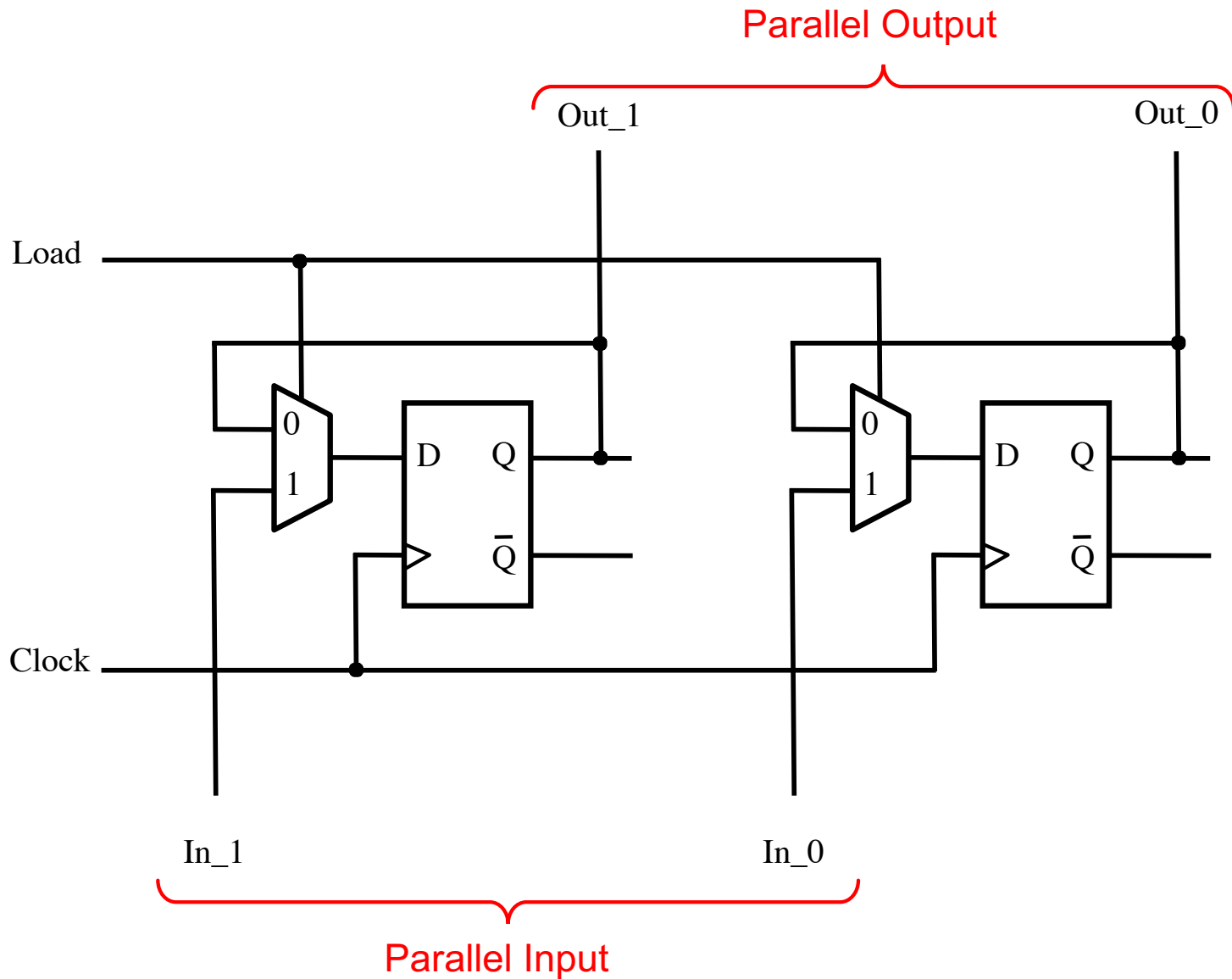

3-Bit Parallel-Access Register

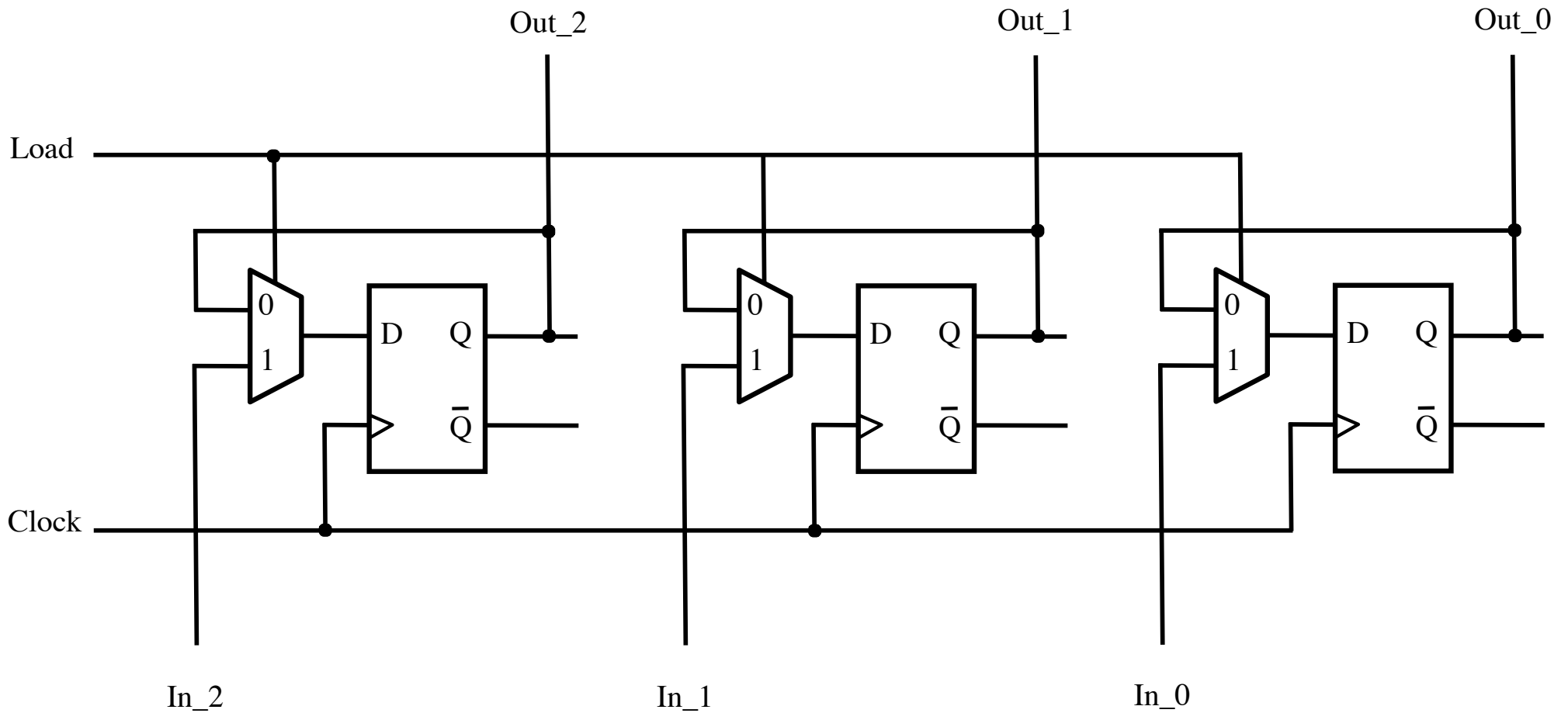

Notice that all flip-flops are on the same clock cycle.

3-Bit Parallel-Access Register

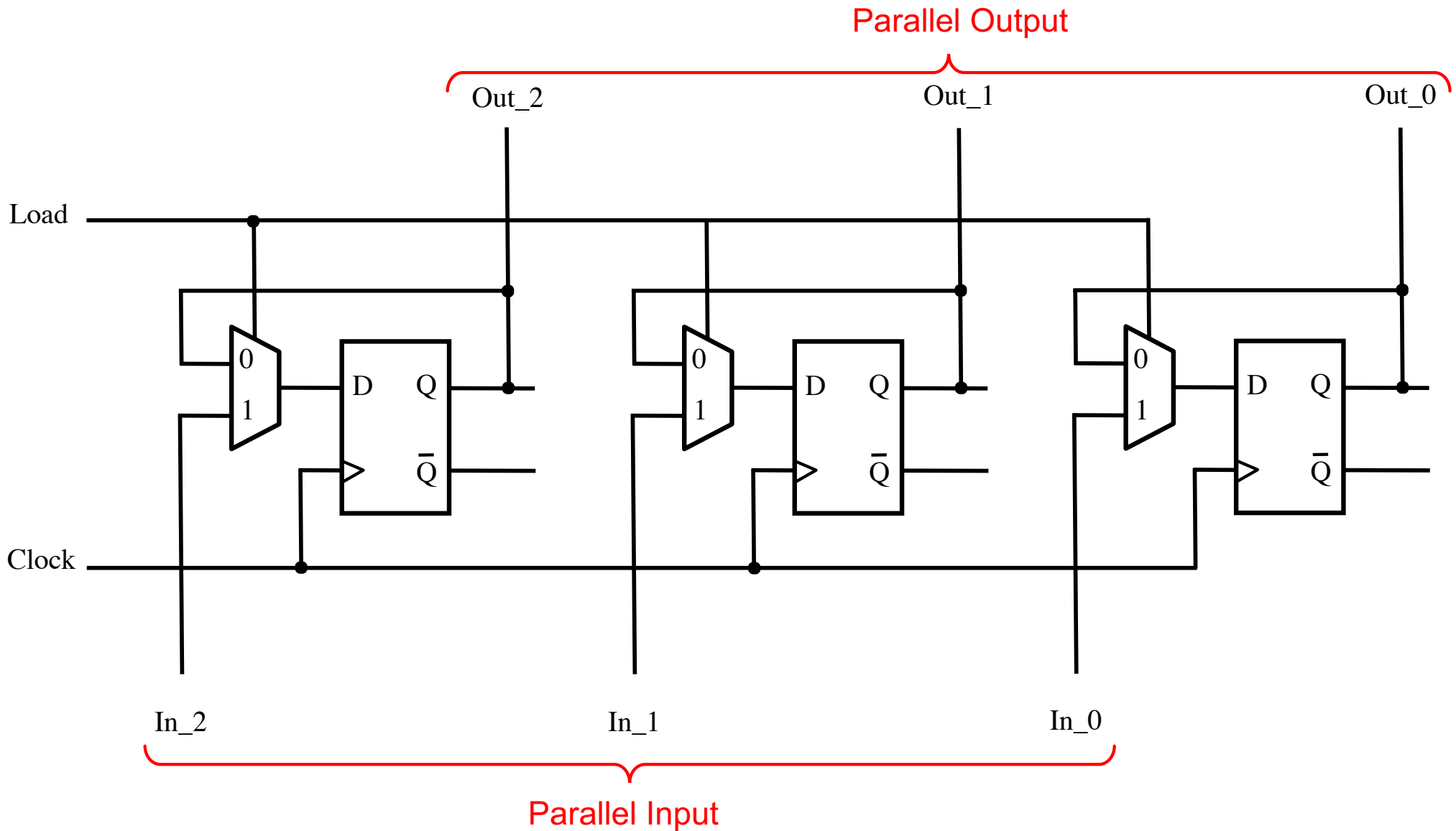

4-Bit Parallel-Access Register

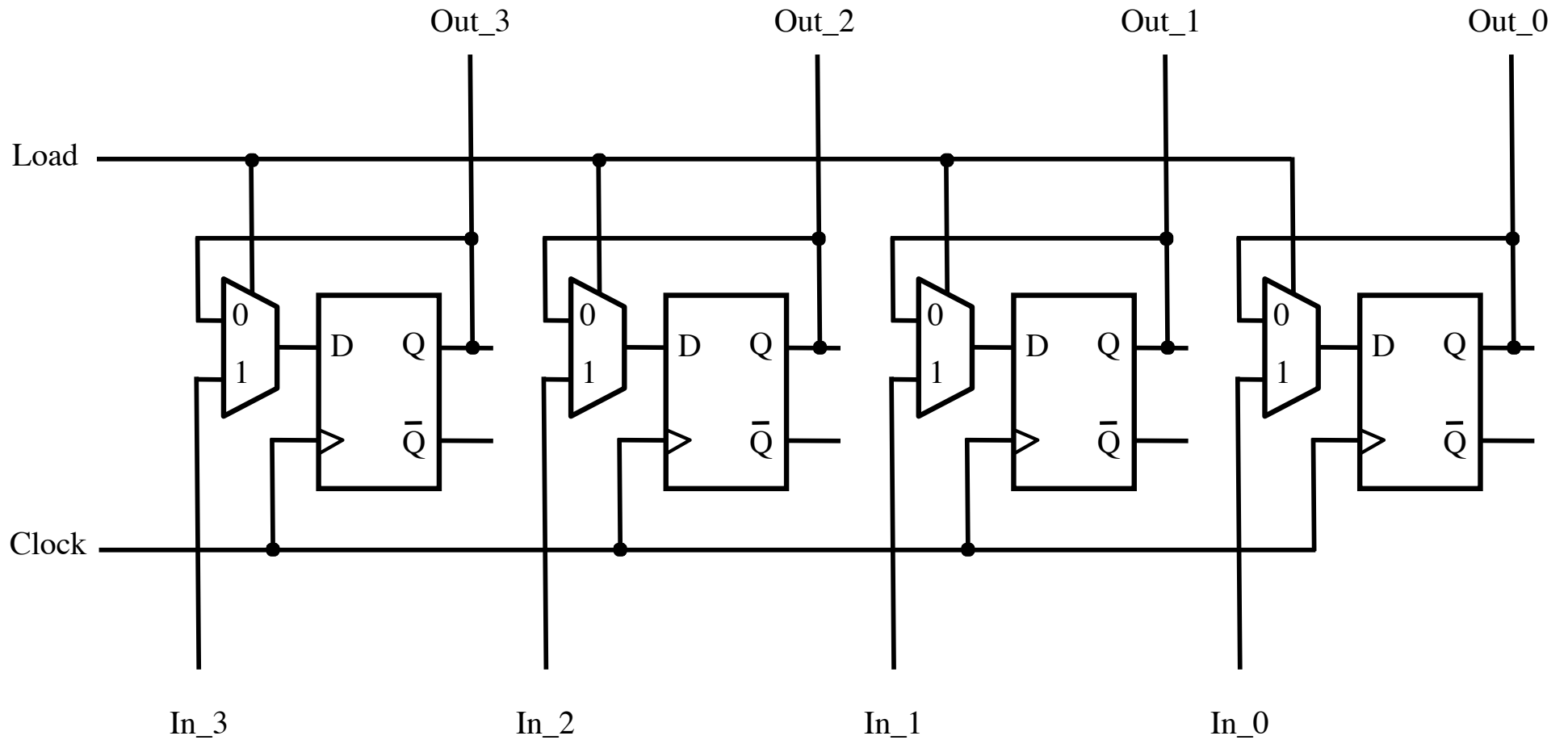

4-Bit Parallel-Access Register

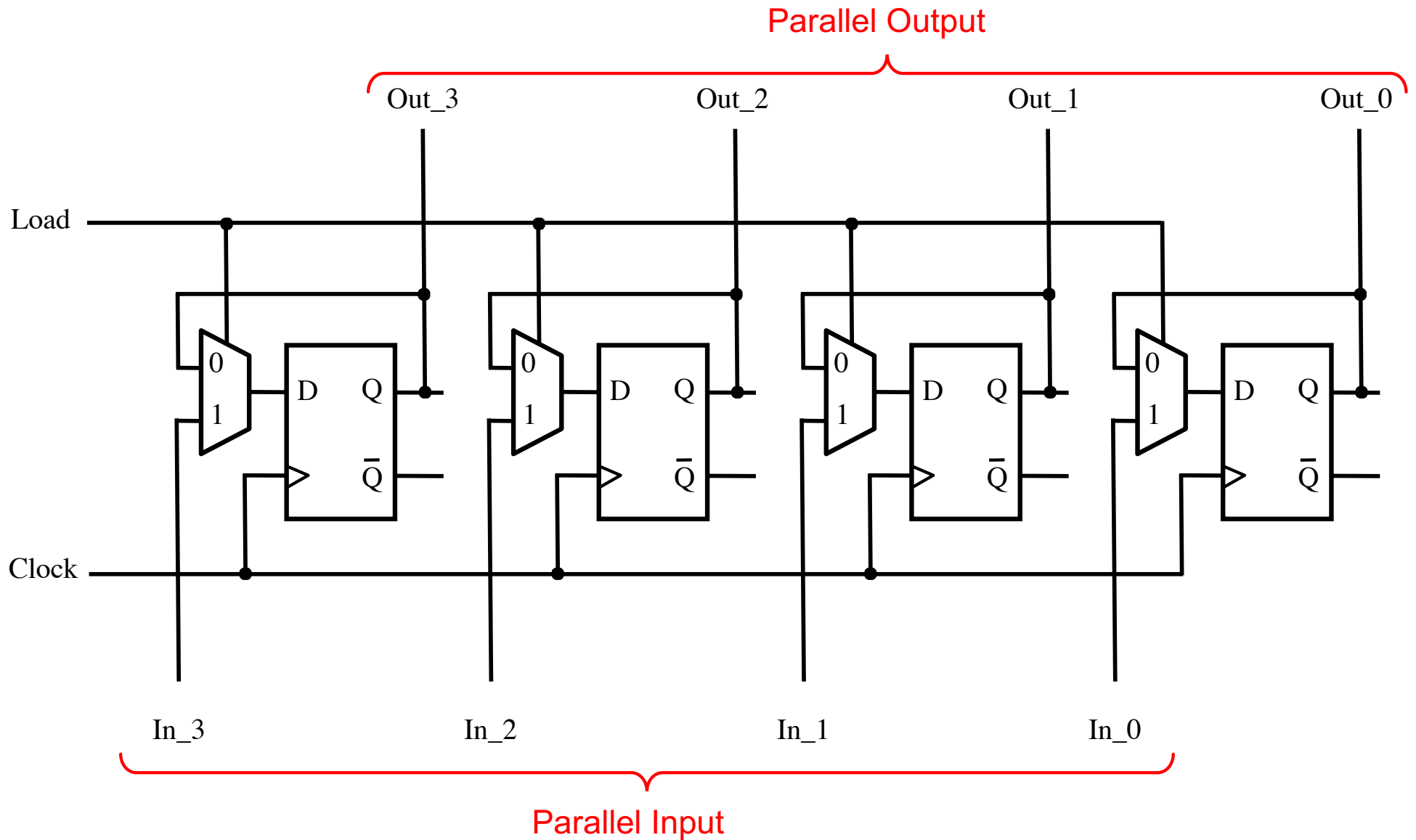

4-Bit Parallel-Access Register

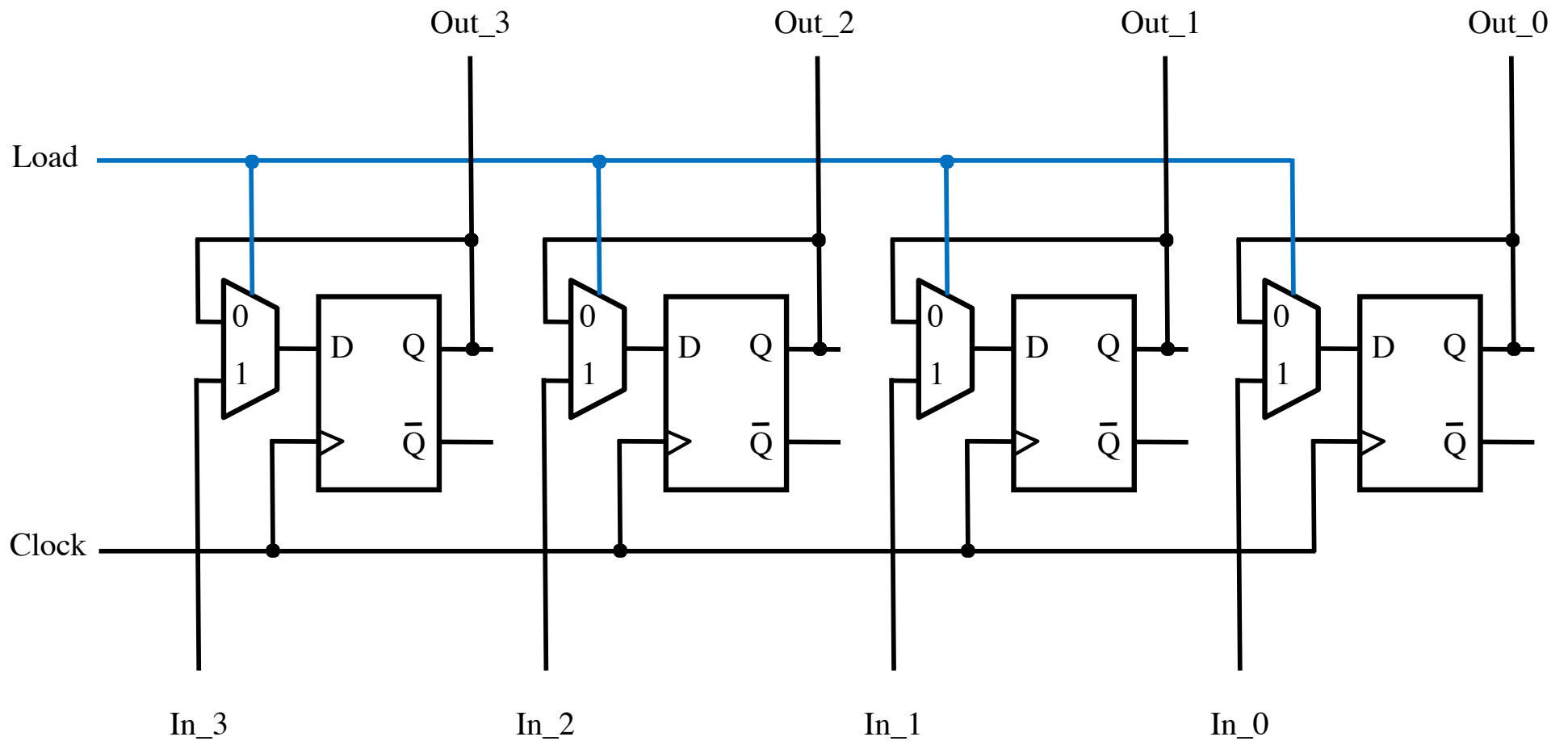

4-Bit Parallel-Access Register

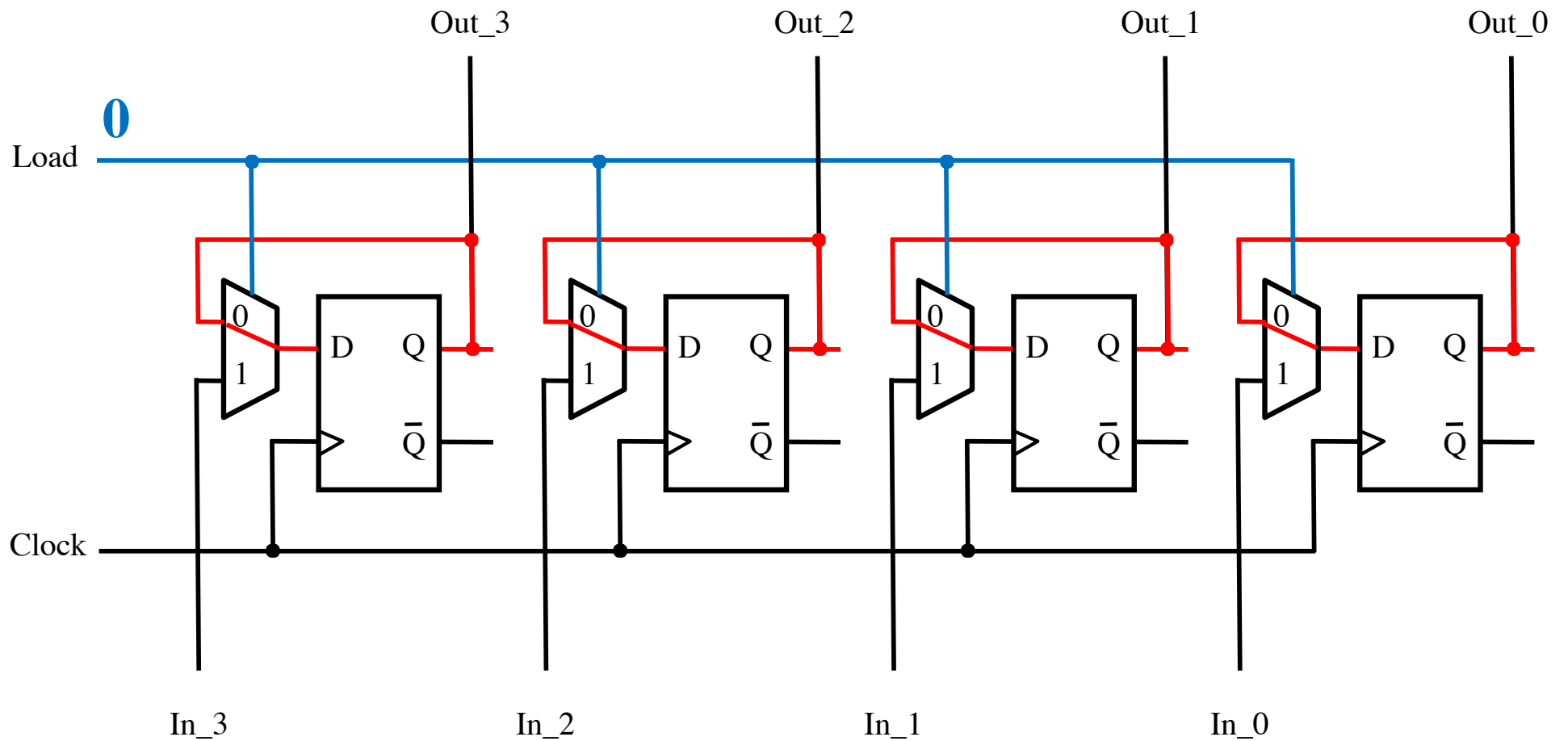

4-Bit Parallel-Access Register

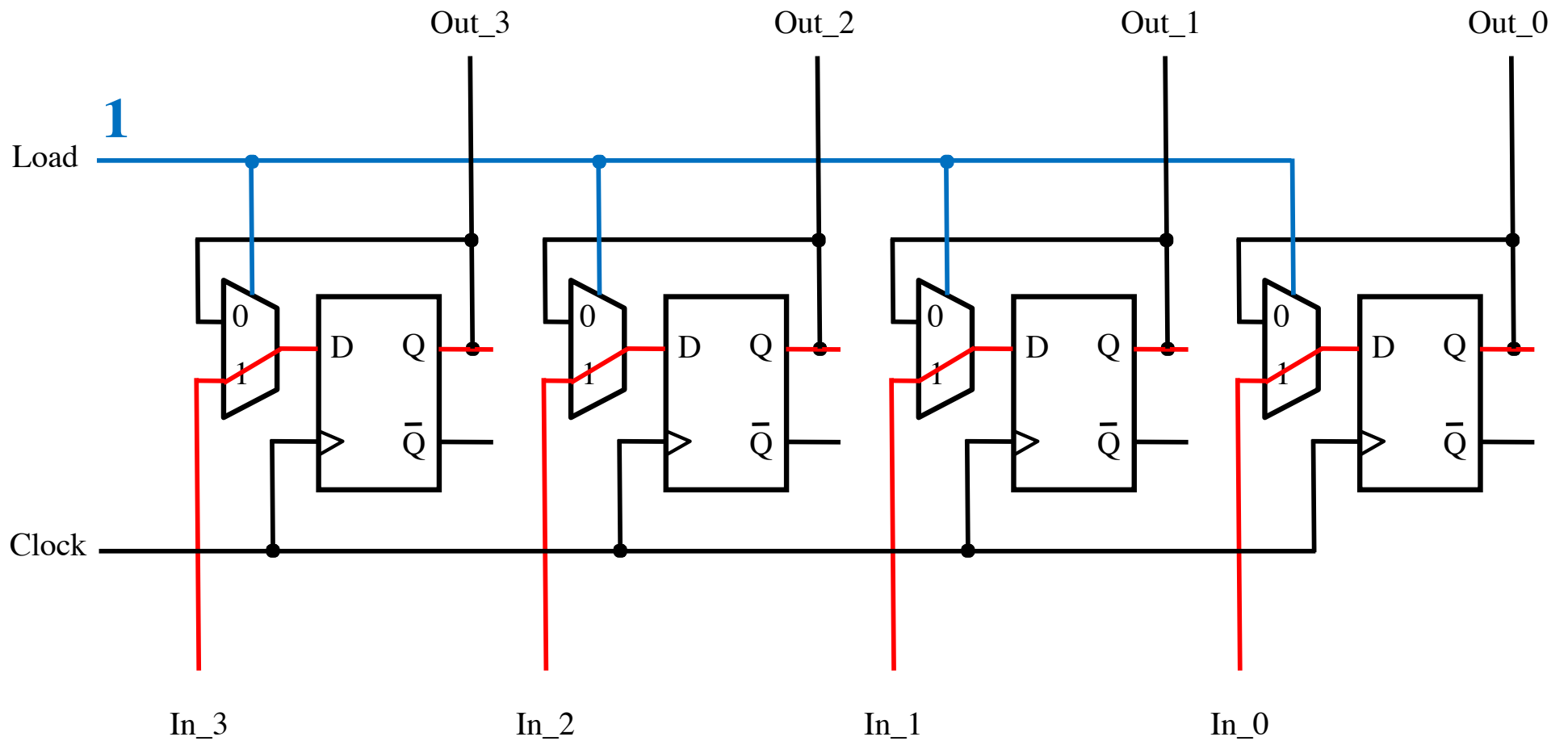

Shift Register

A simple shift register

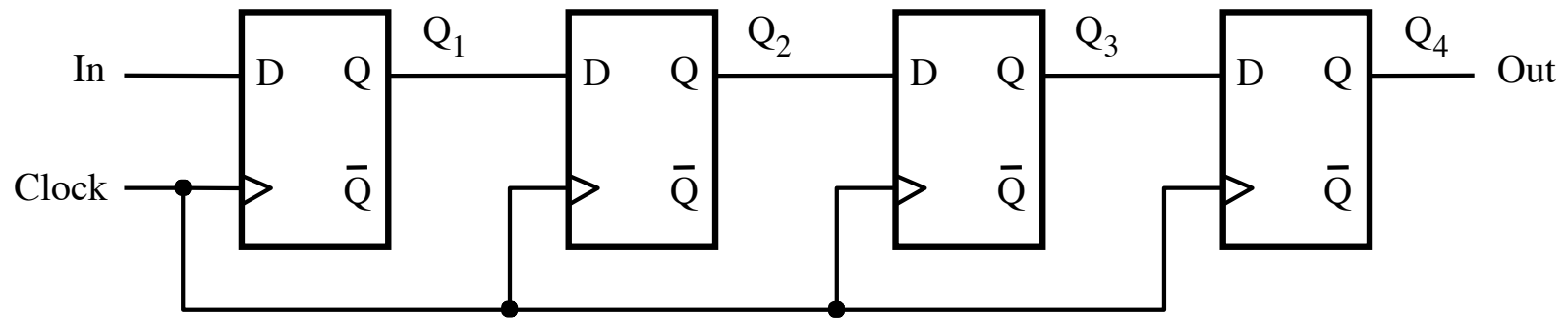

A simple shift register

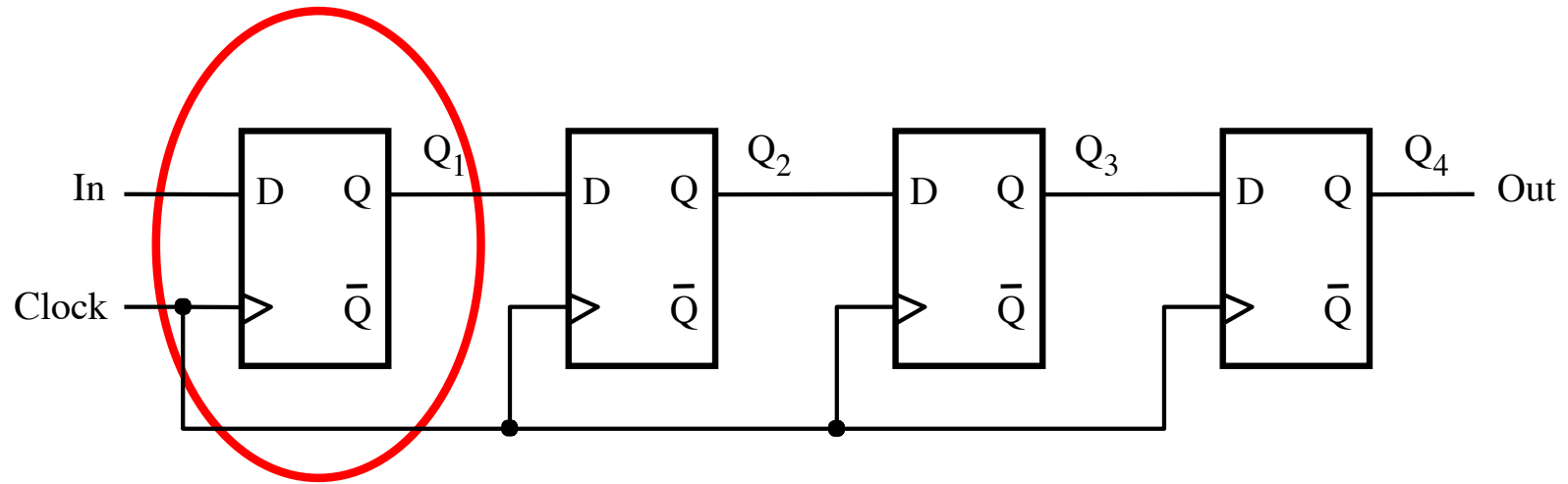

Positive-edge-triggered
D Flip-Flop

A simple shift register

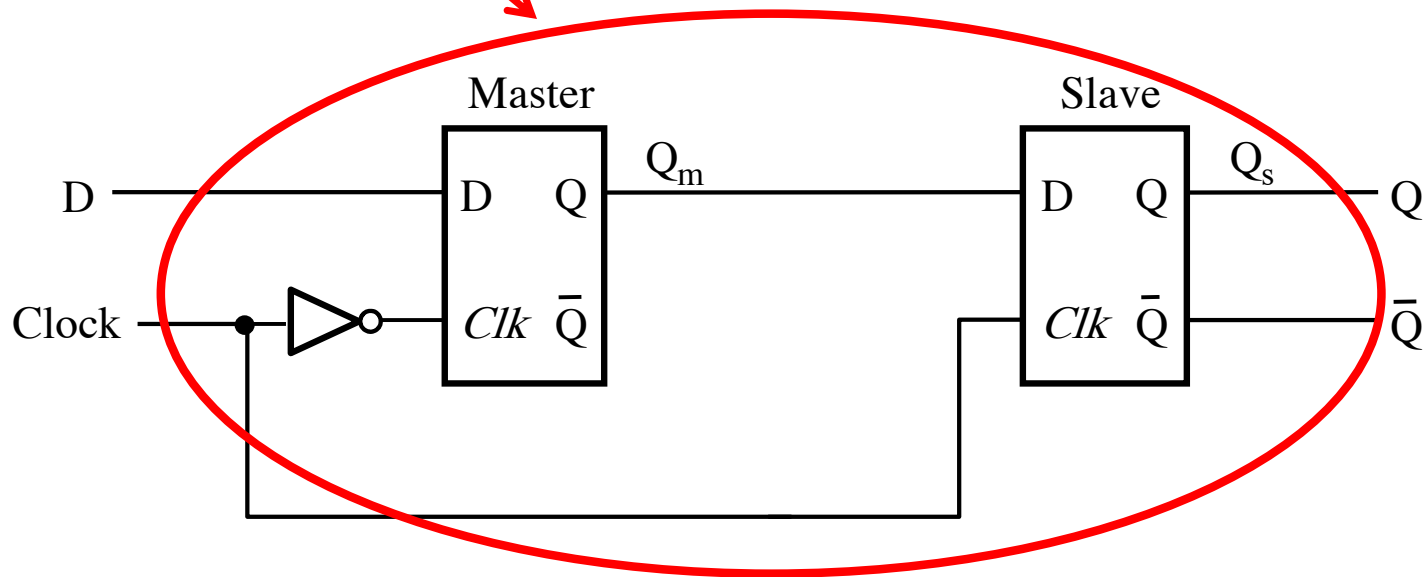
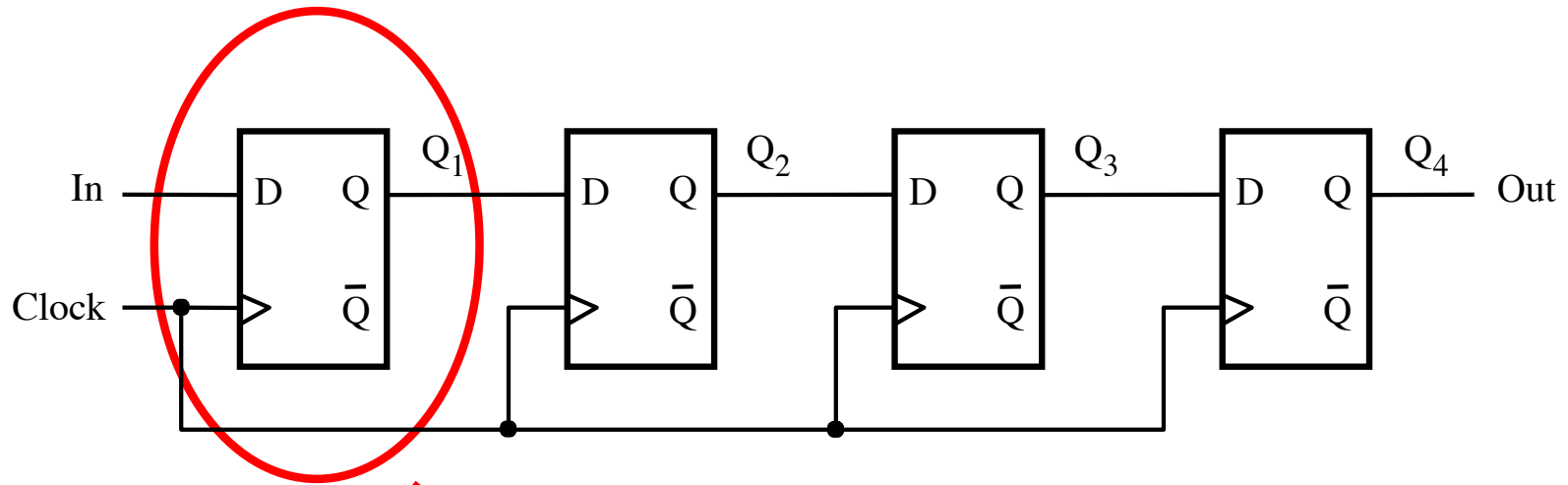

A simple shift register

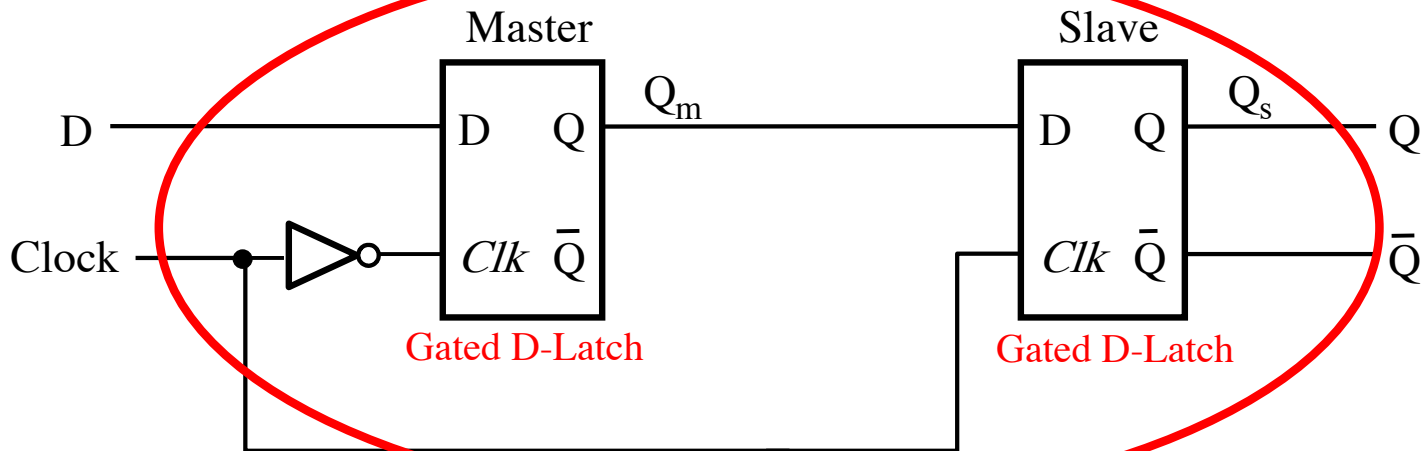
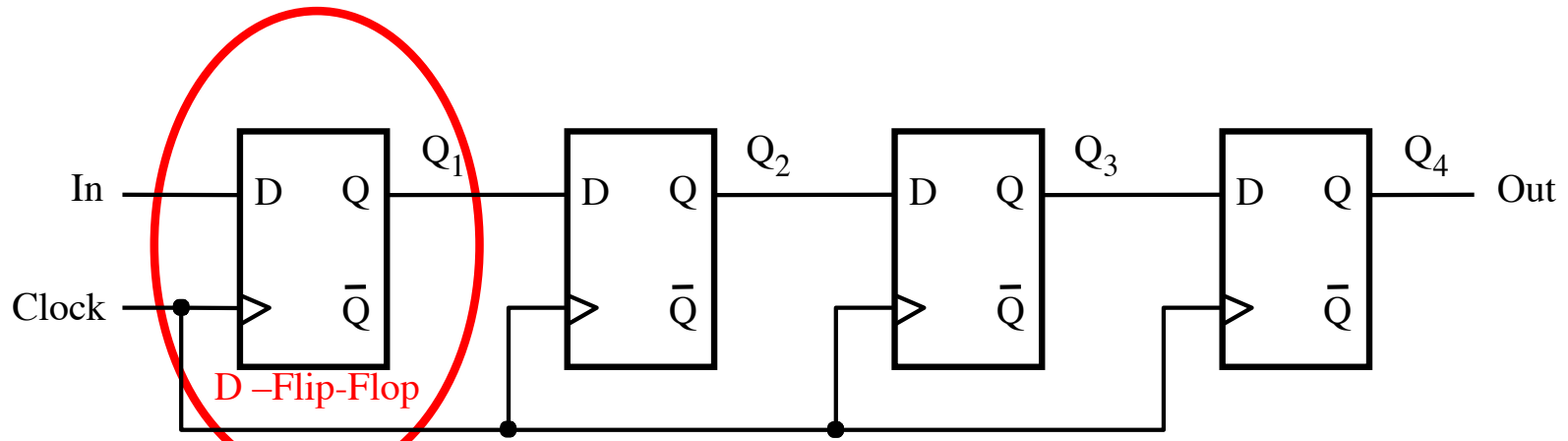

A simple shift register

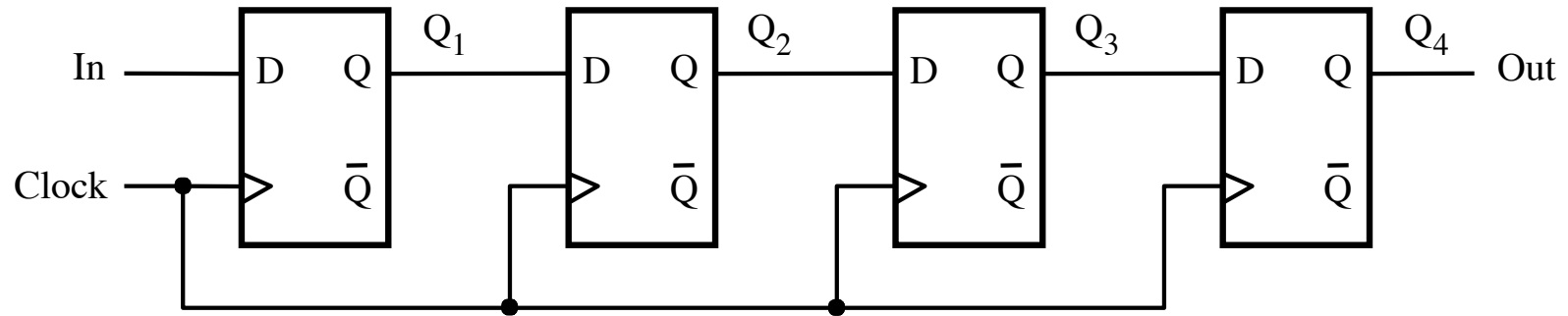

A simple shift register

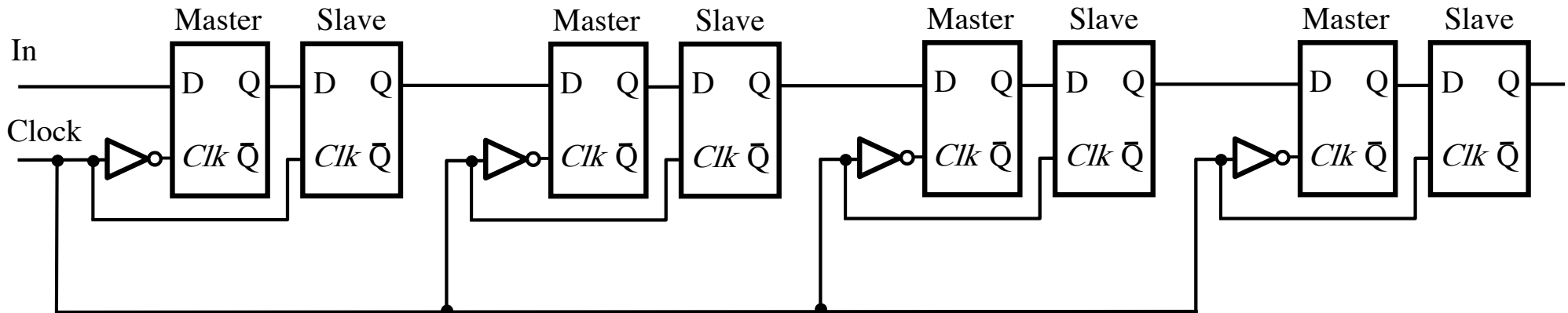
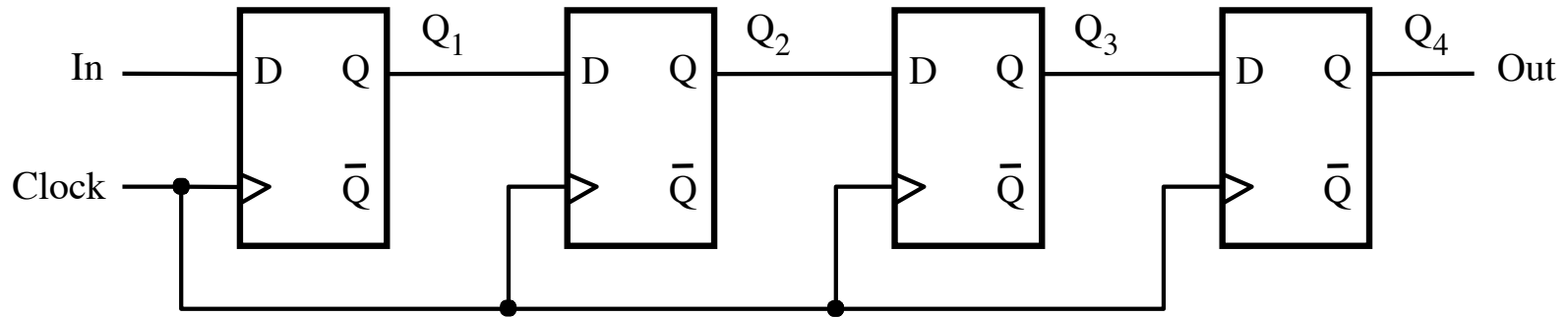

A simple shift register

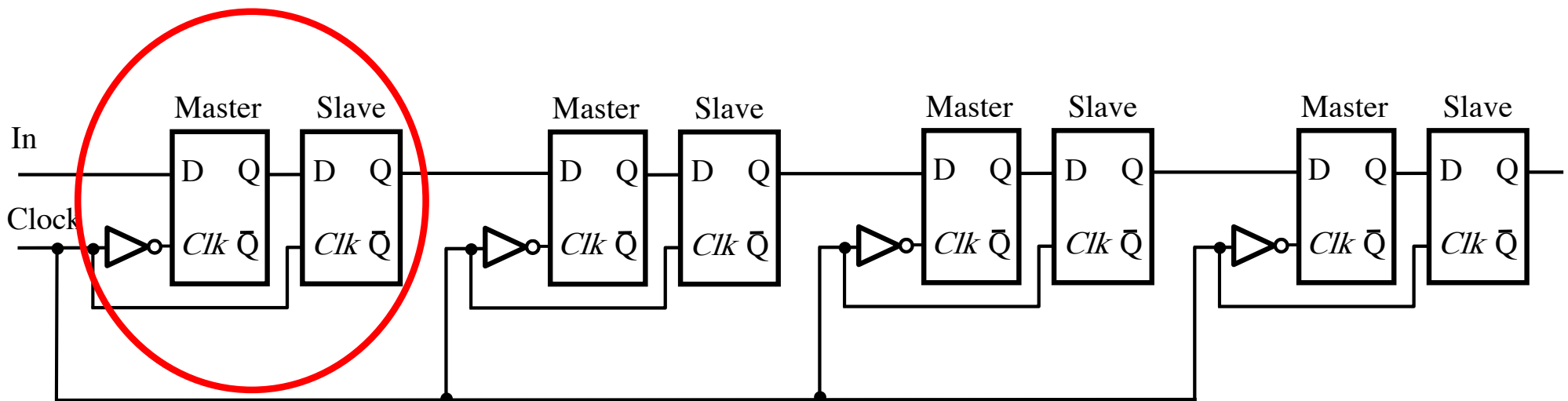
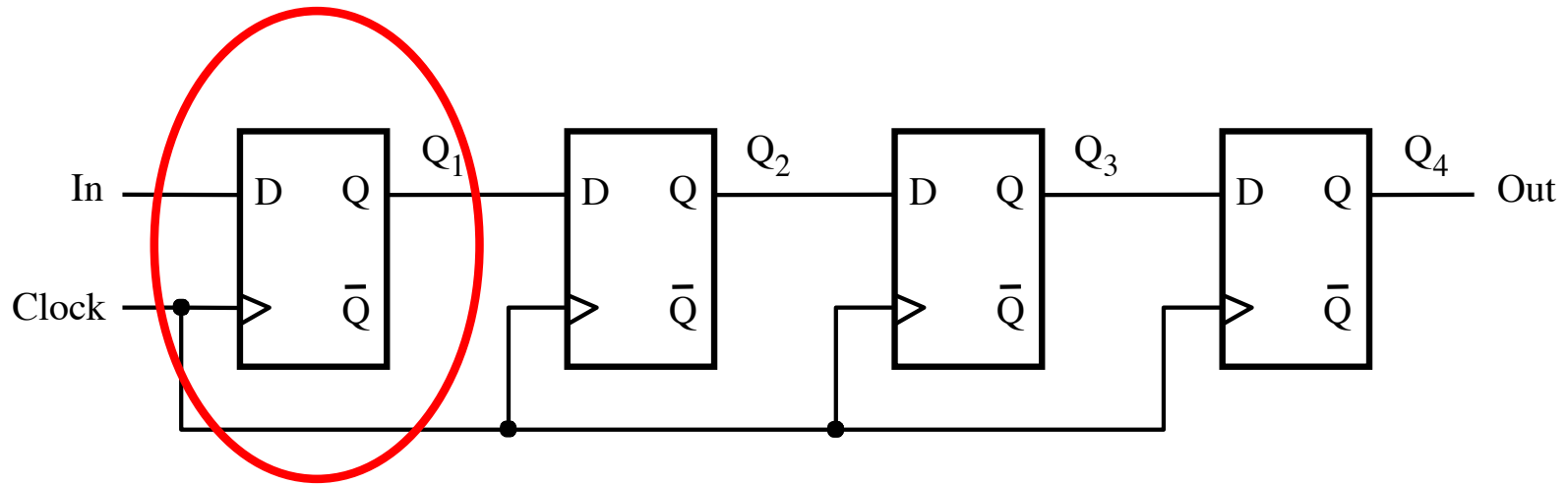

A simple shift register

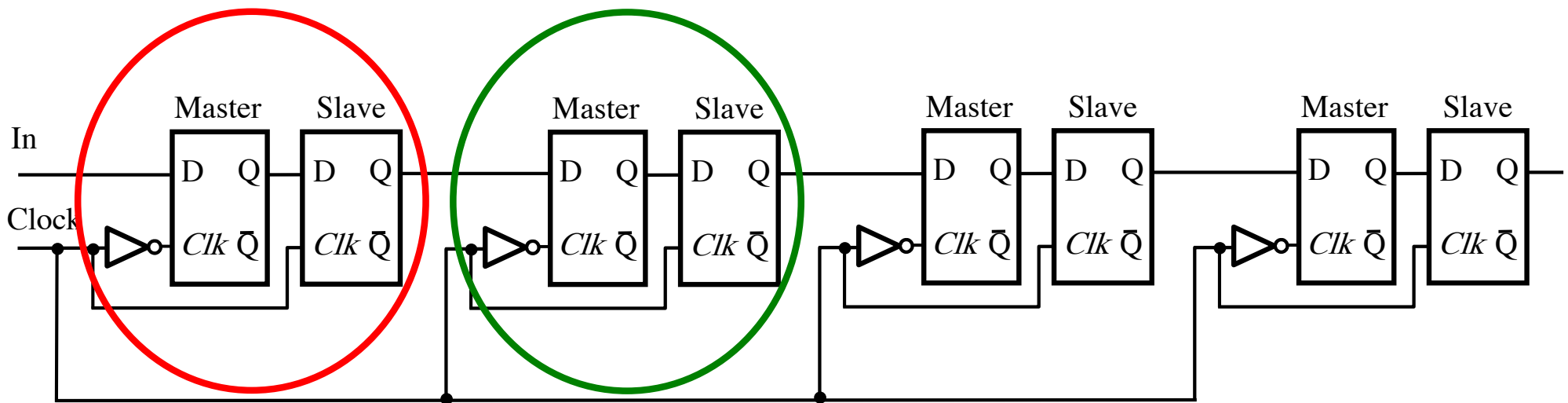
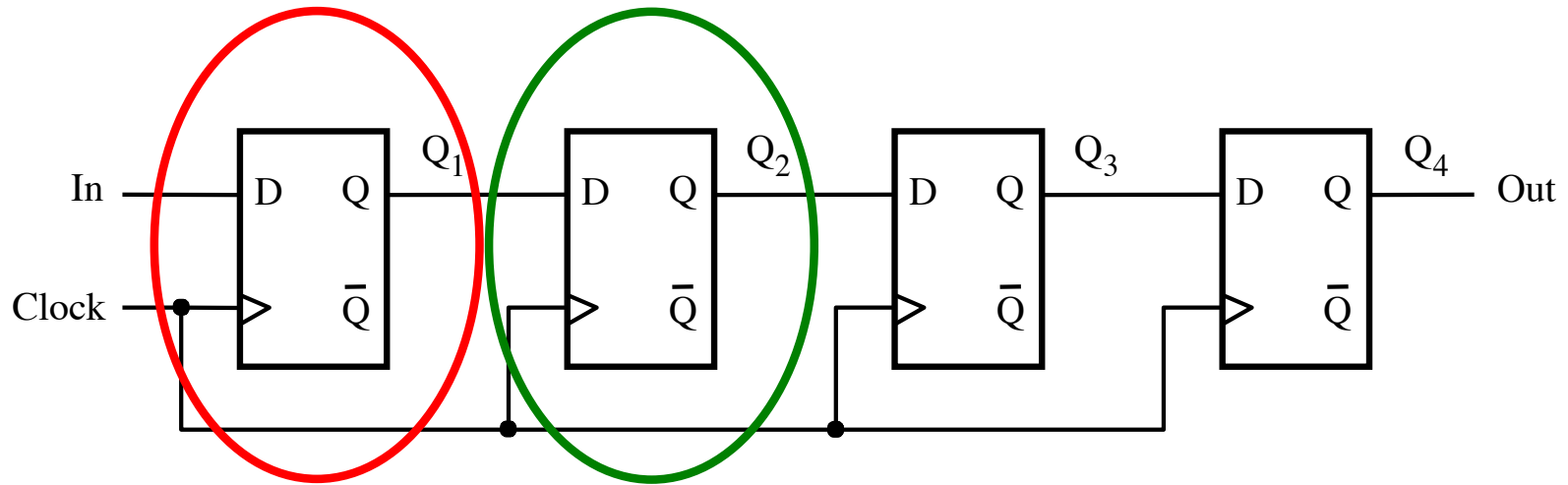

A simple shift register

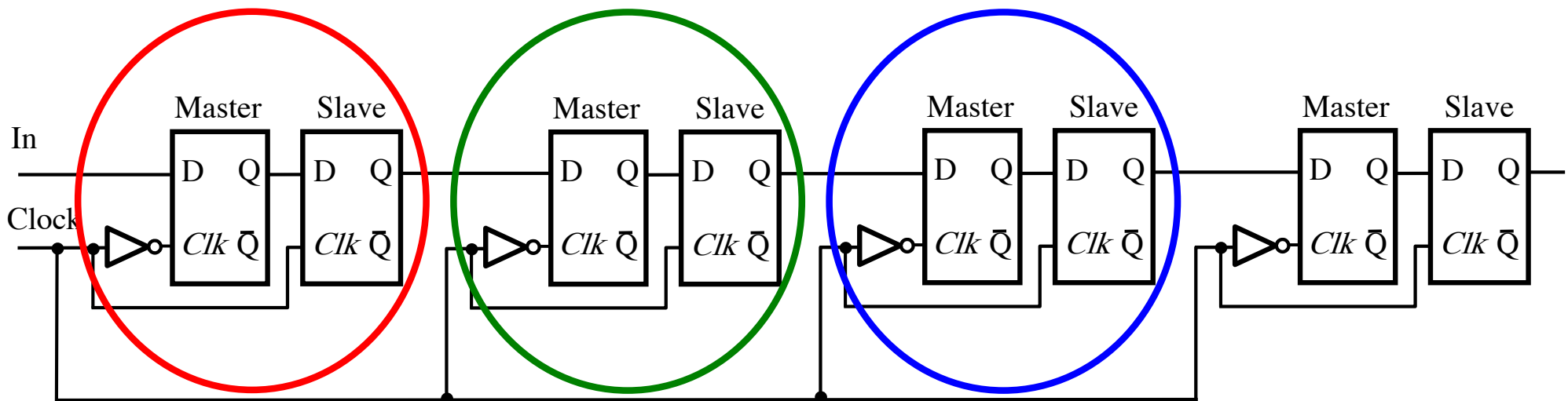
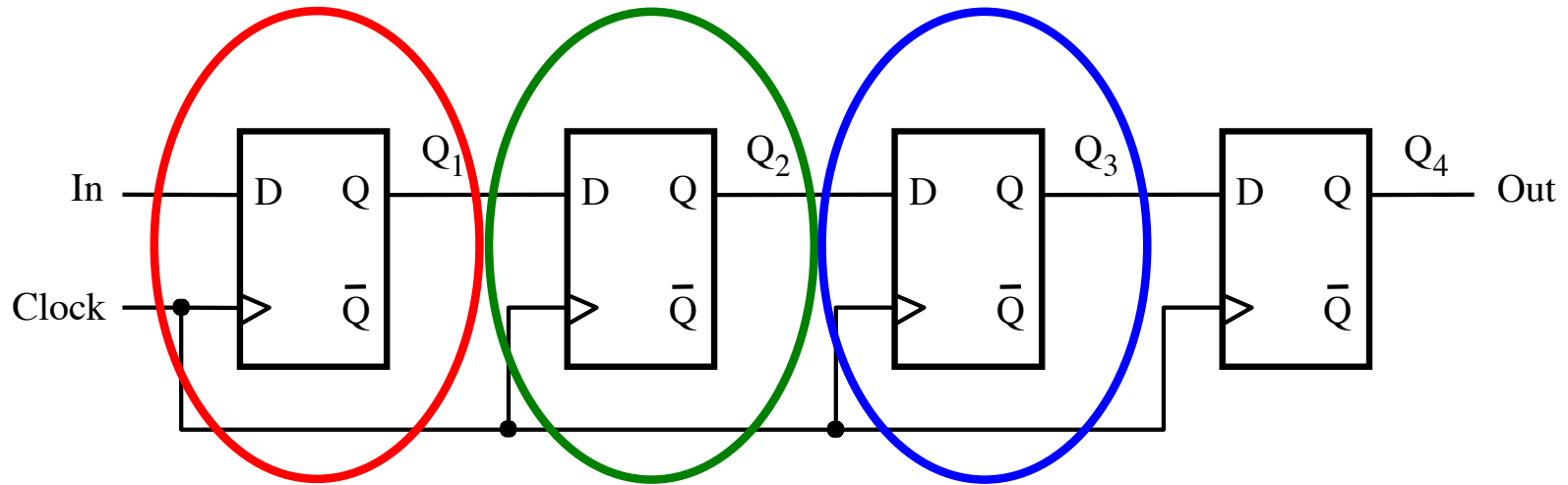

A simple shift register

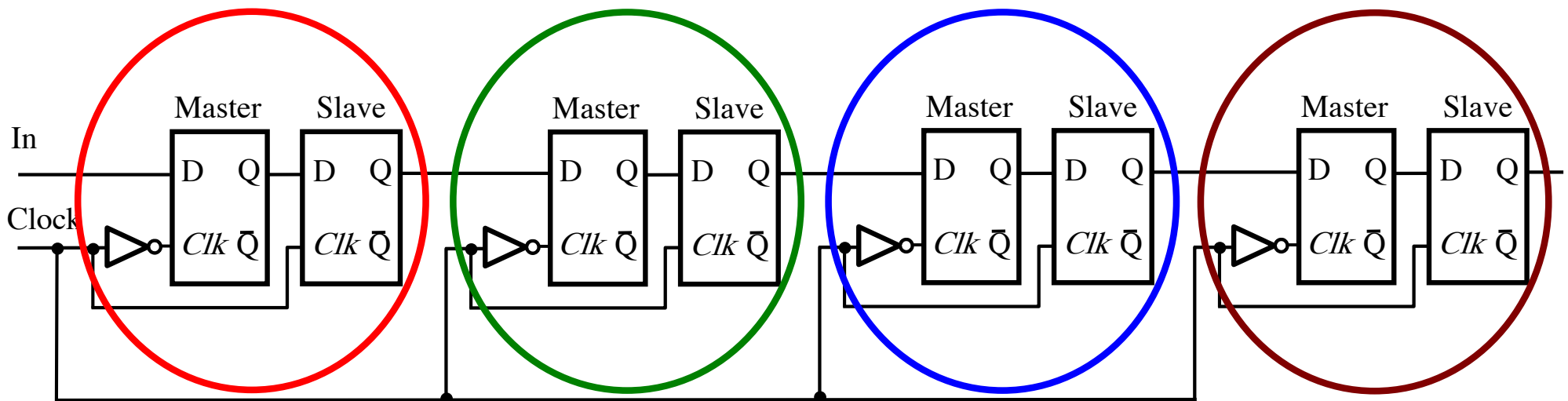
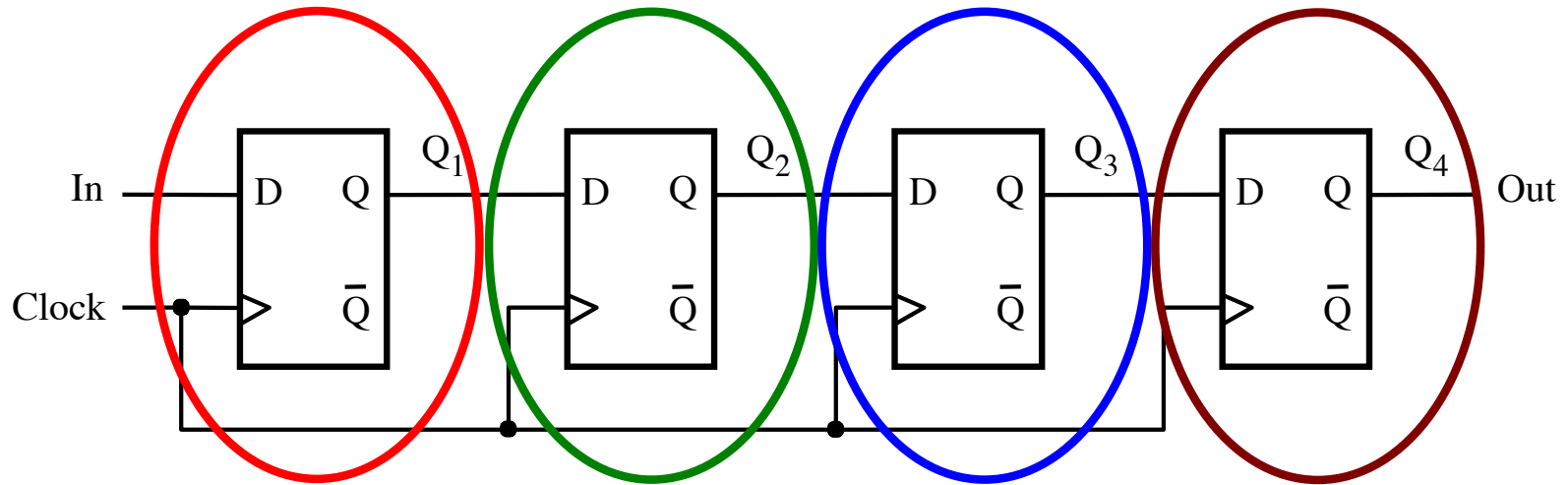

A simple shift register

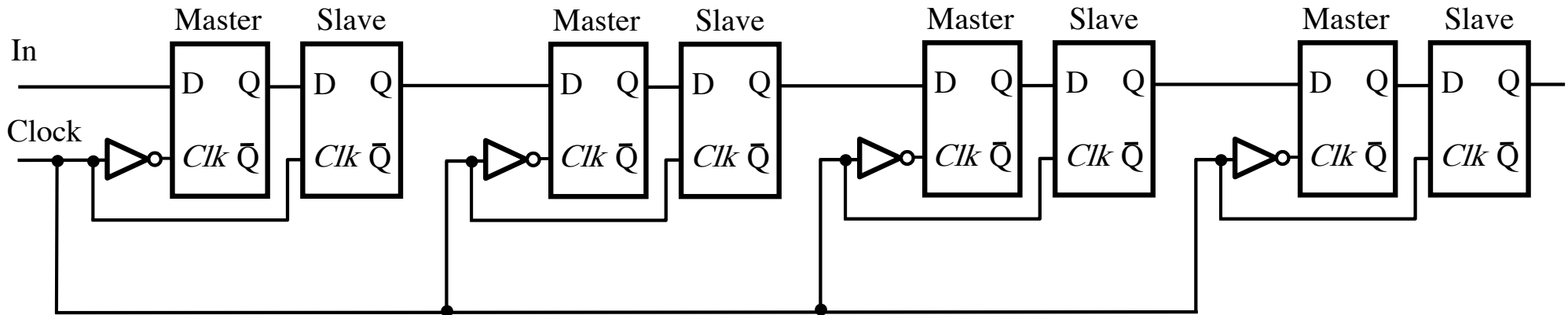

A simple shift register

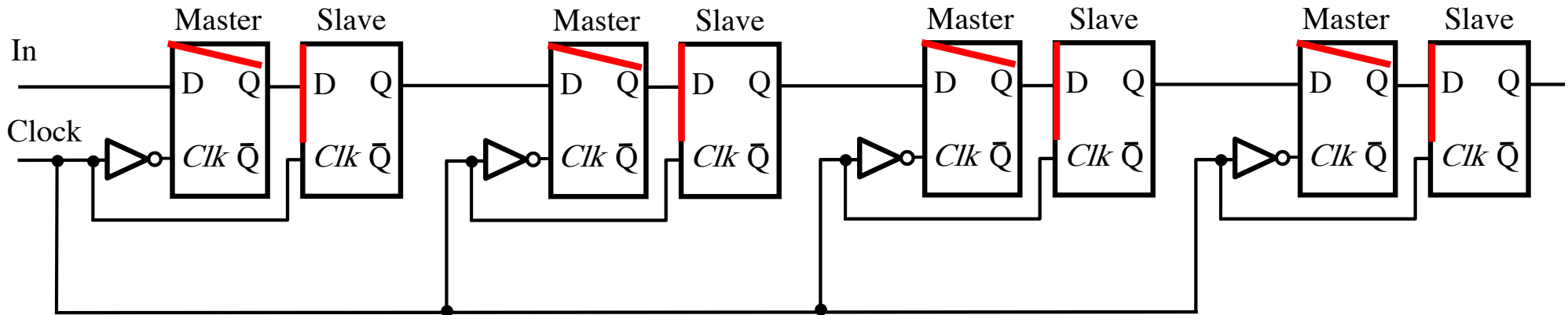

A simple shift register

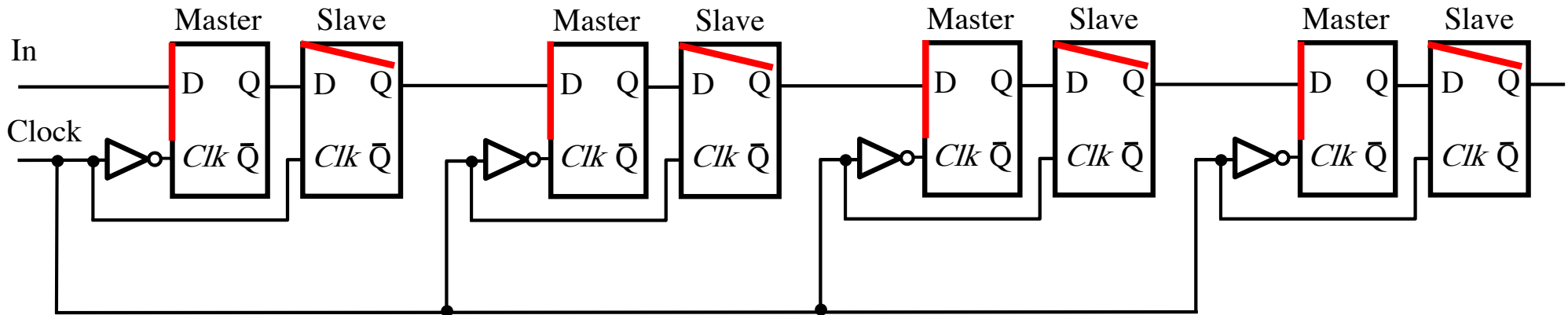

A simple shift register

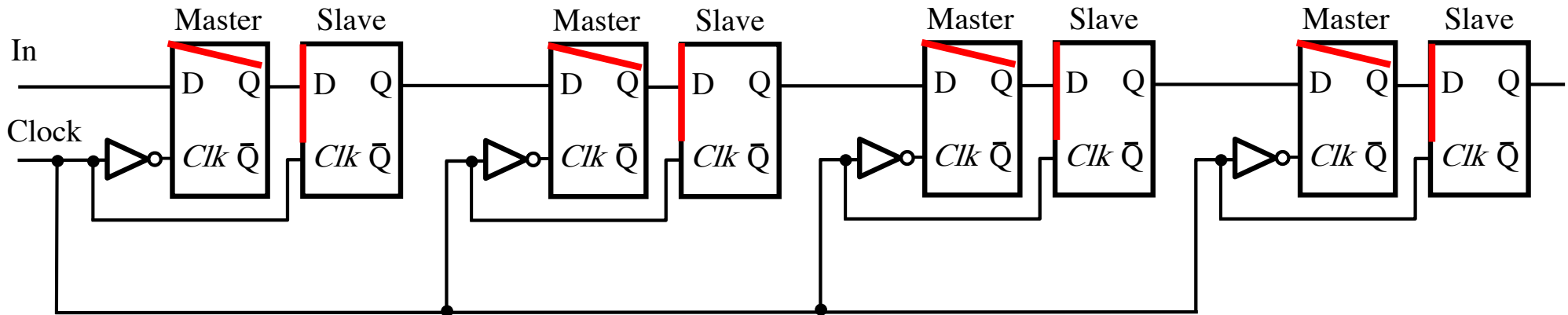

Clock



A simple shift register

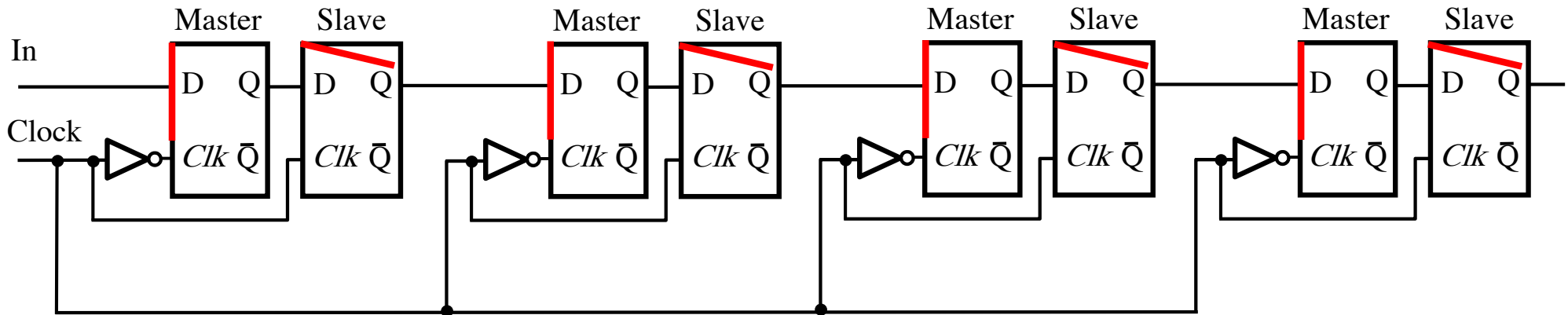

A simple shift register

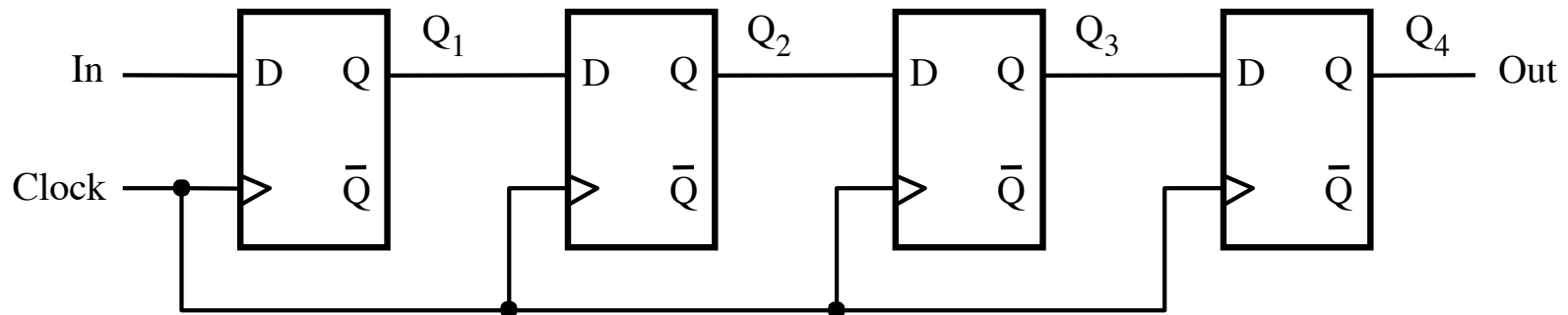

(a) Circuit

	In	Q_1	Q_2	Q_3	$Q_4 = \text{Out}$
t_0	1	0	0	0	0
t_1	0	1	0	0	0
t_2	1	0	1	0	0
t_3	1	1	0	1	0
t_4	1	1	1	0	1
t_5	0	1	1	1	0
t_6	0	0	1	1	1
t_7	0	0	0	1	1

(b) A sample sequence

Parallel-Access Shift Register

Parallel-access shift register

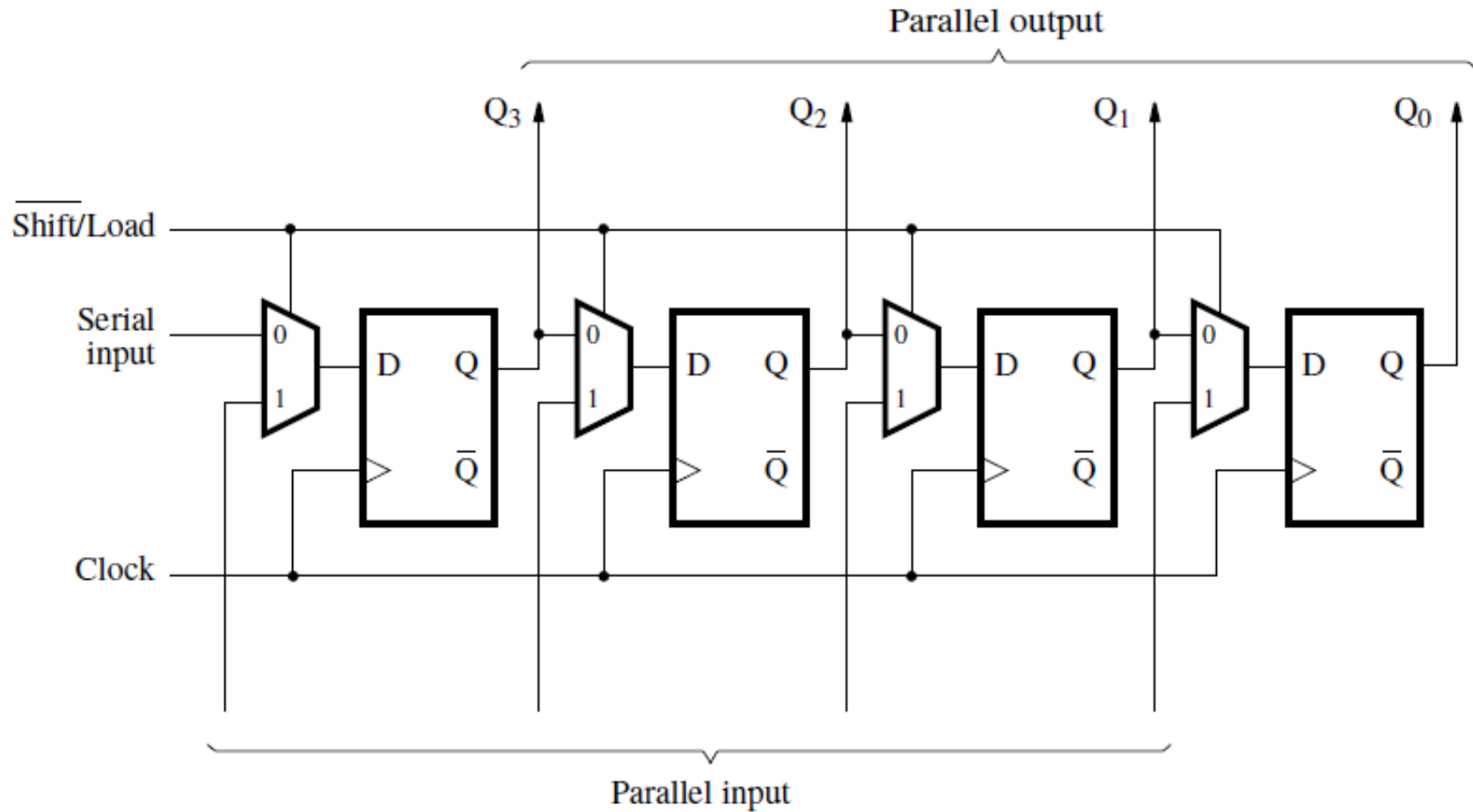

Parallel-access shift register

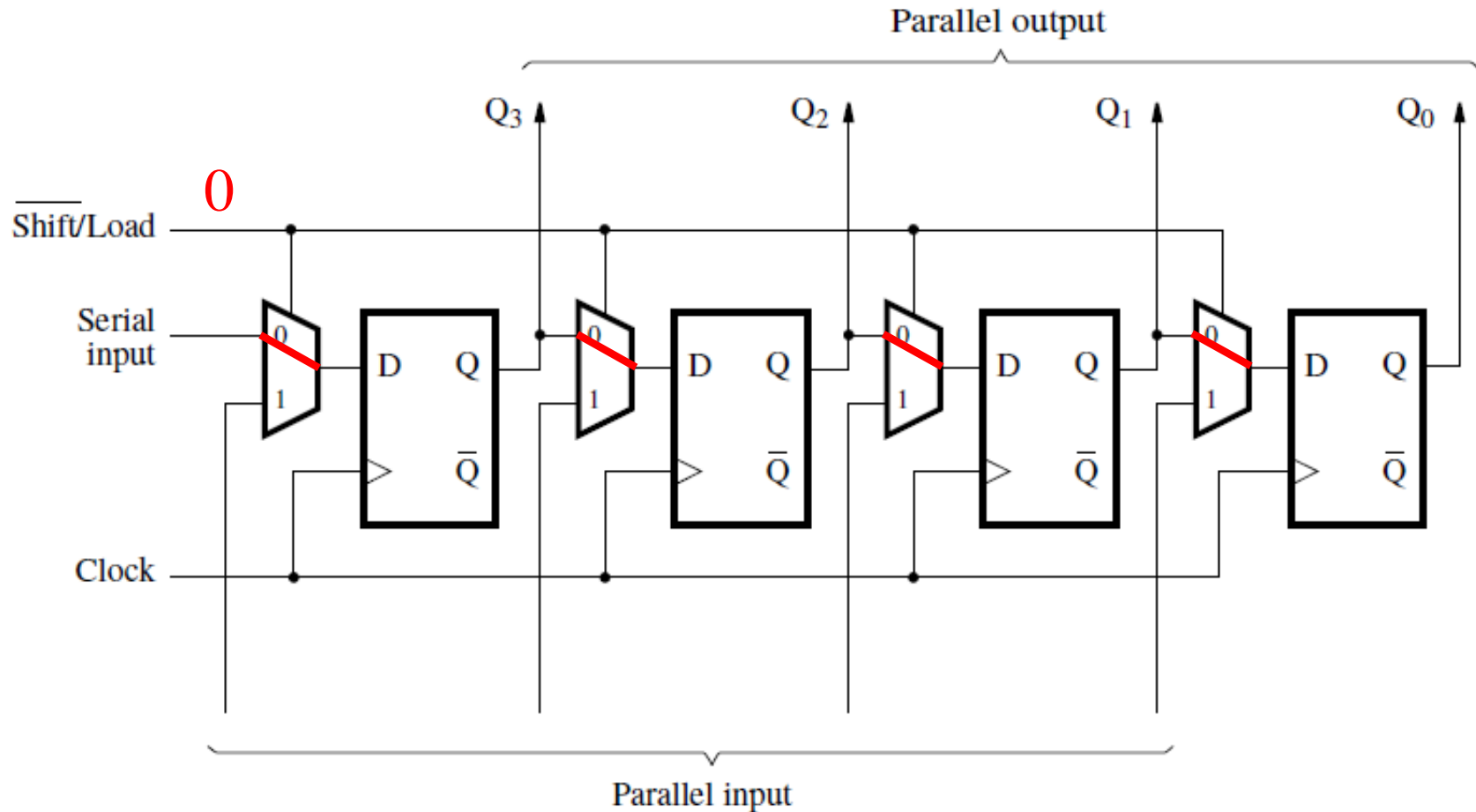

When Load=0, this behaves like a shift register.

Parallel-access shift register

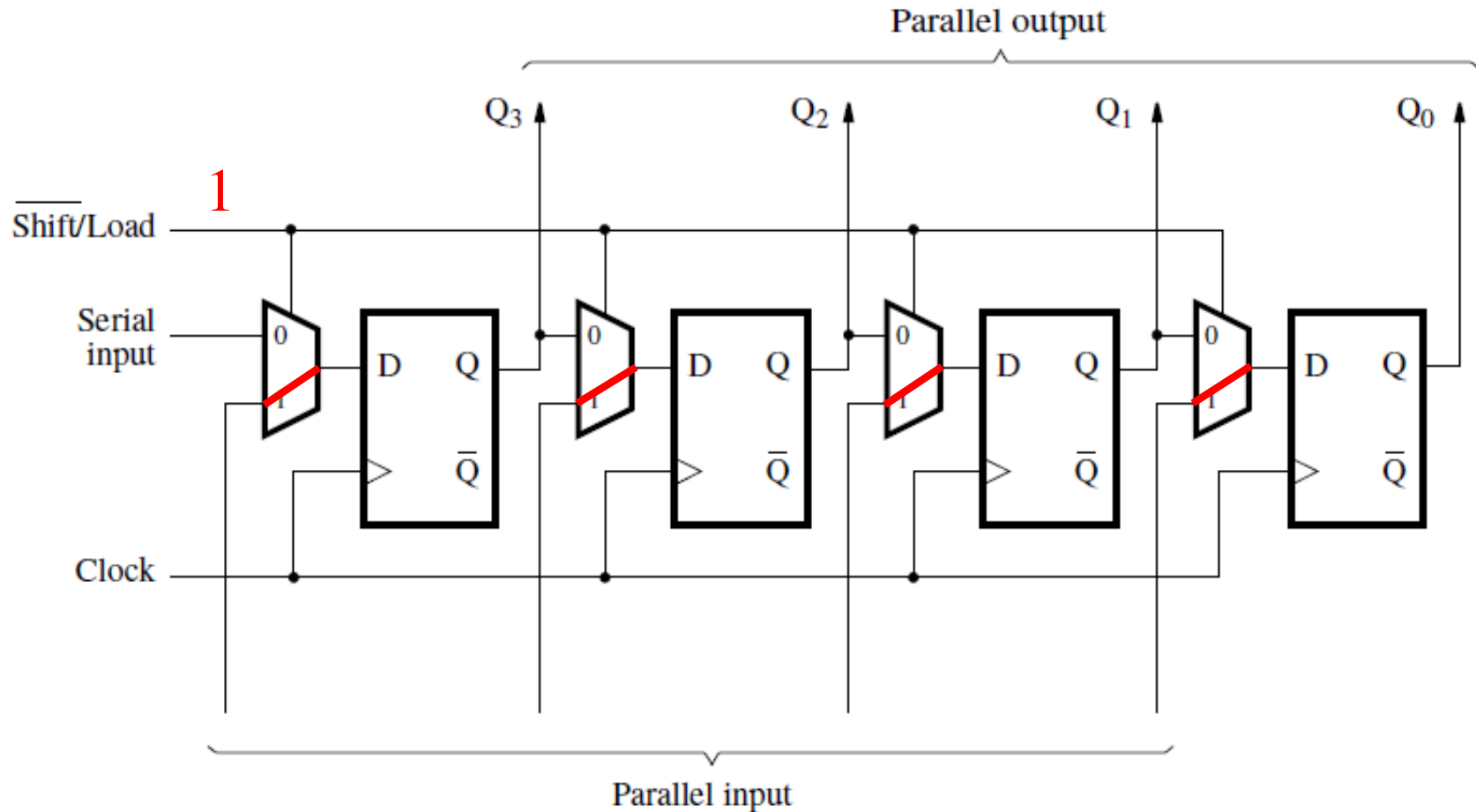

When Load=1, this behaves like a parallel-access register.

Shift Register With Parallel Load and Enable

A shift register with parallel load and enable control inputs

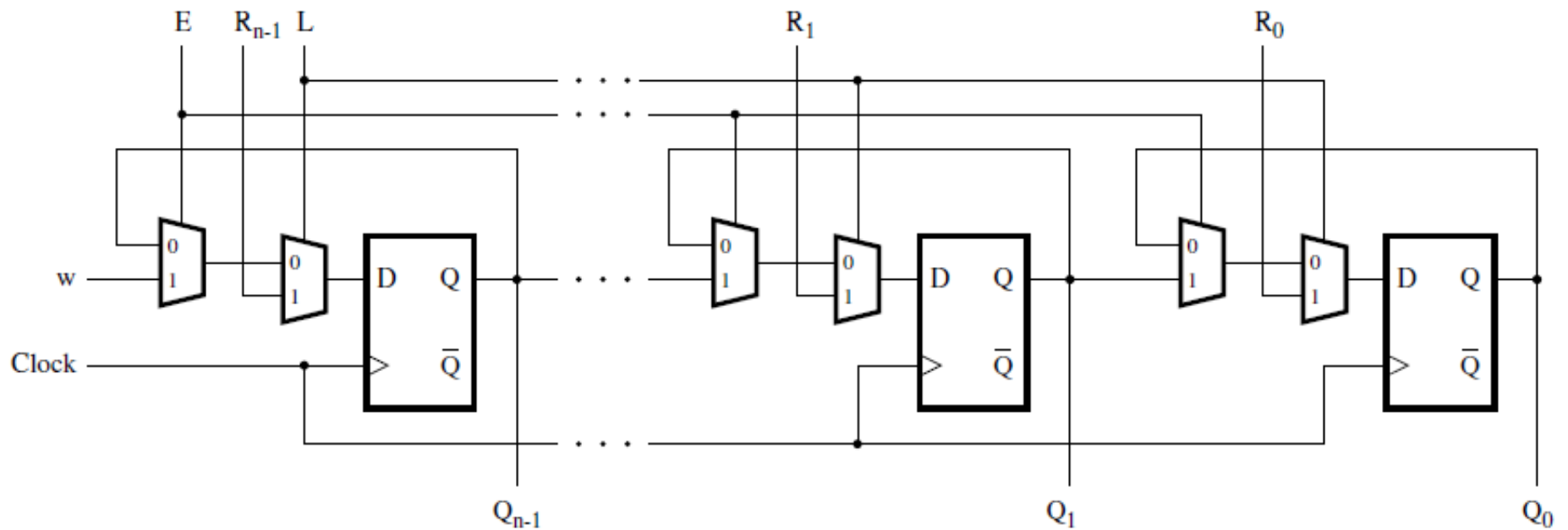

A shift register with parallel load and enable control inputs

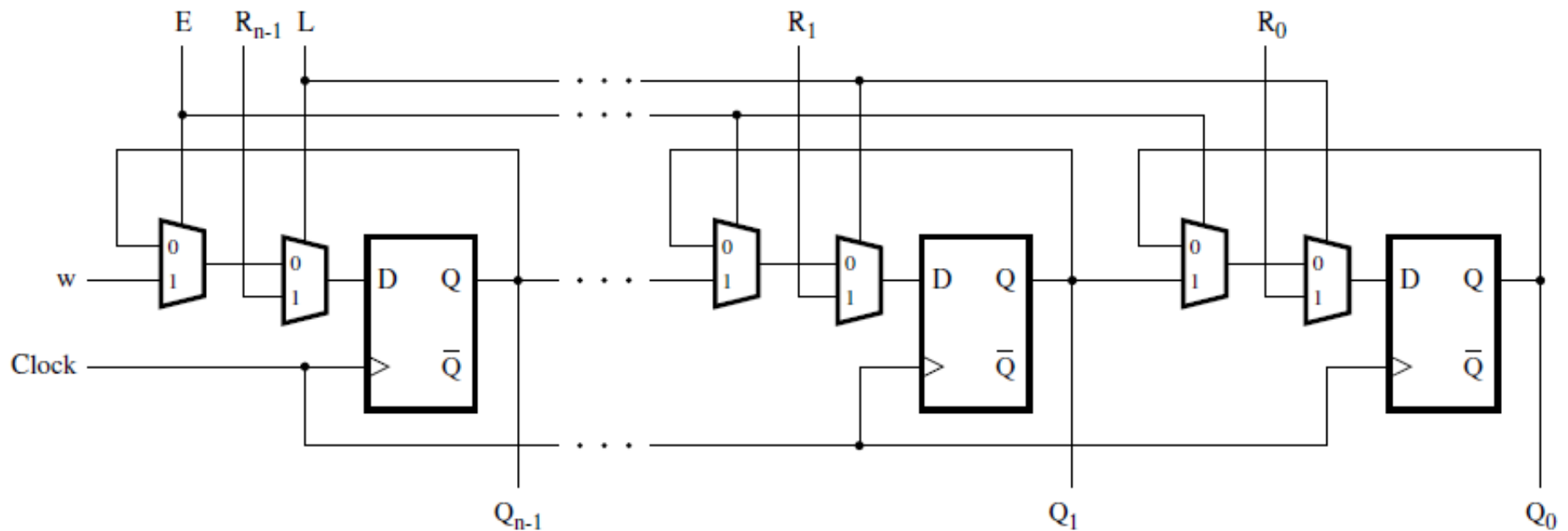

The directions of the input and output lines are switched relative to the previous slides.

A shift register with parallel load and enable control inputs

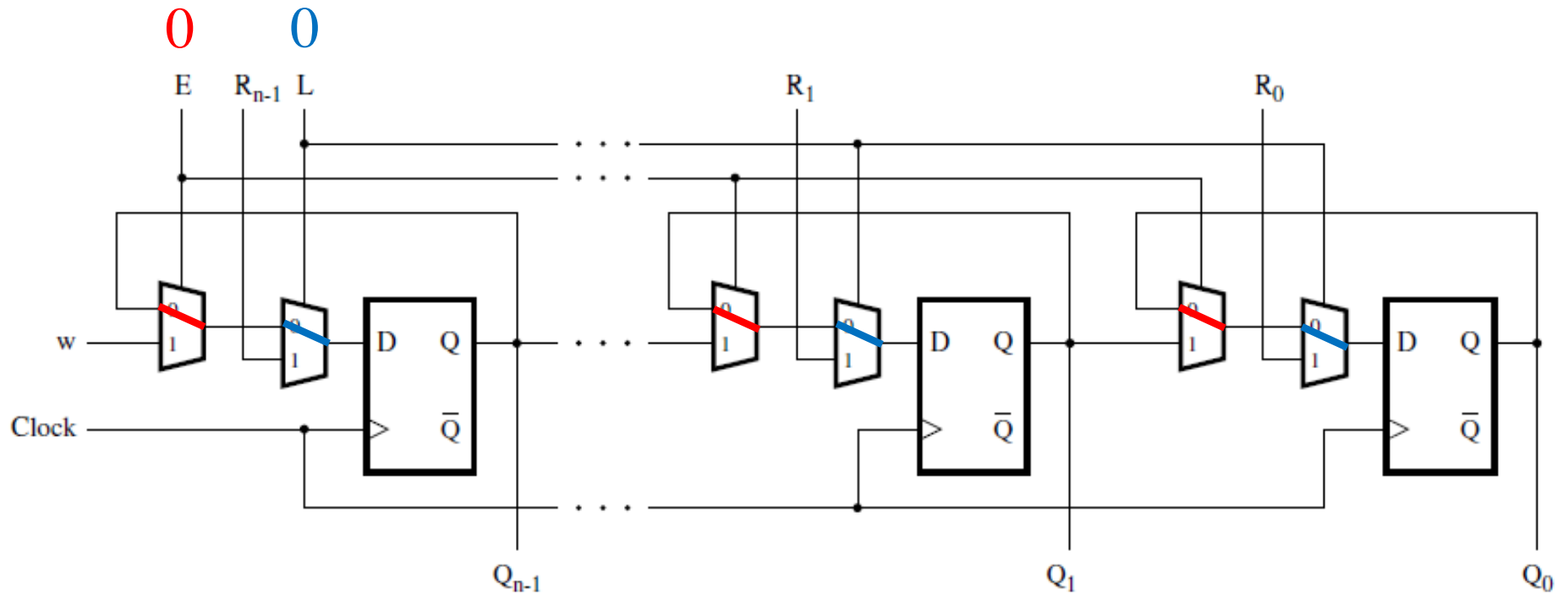

[Figure 5.59 from the textbook]

A shift register with parallel load and enable control inputs

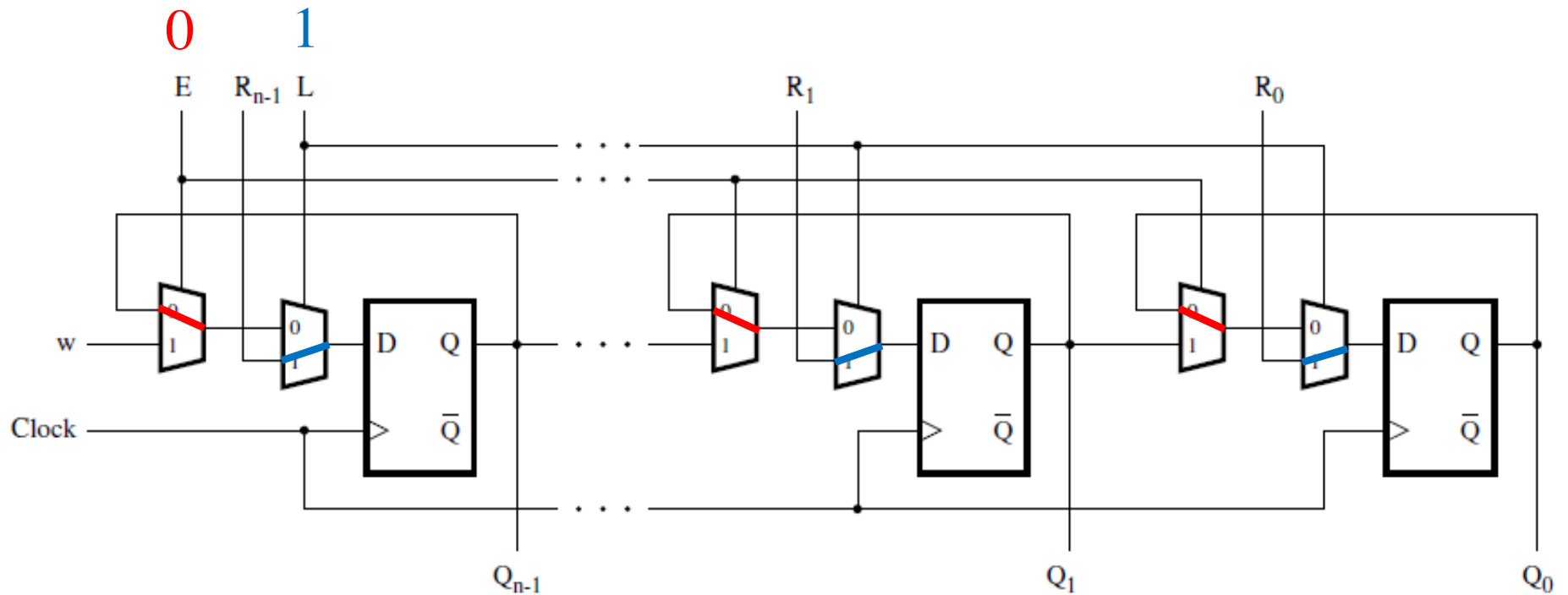

[Figure 5.59 from the textbook]

A shift register with parallel load and enable control inputs

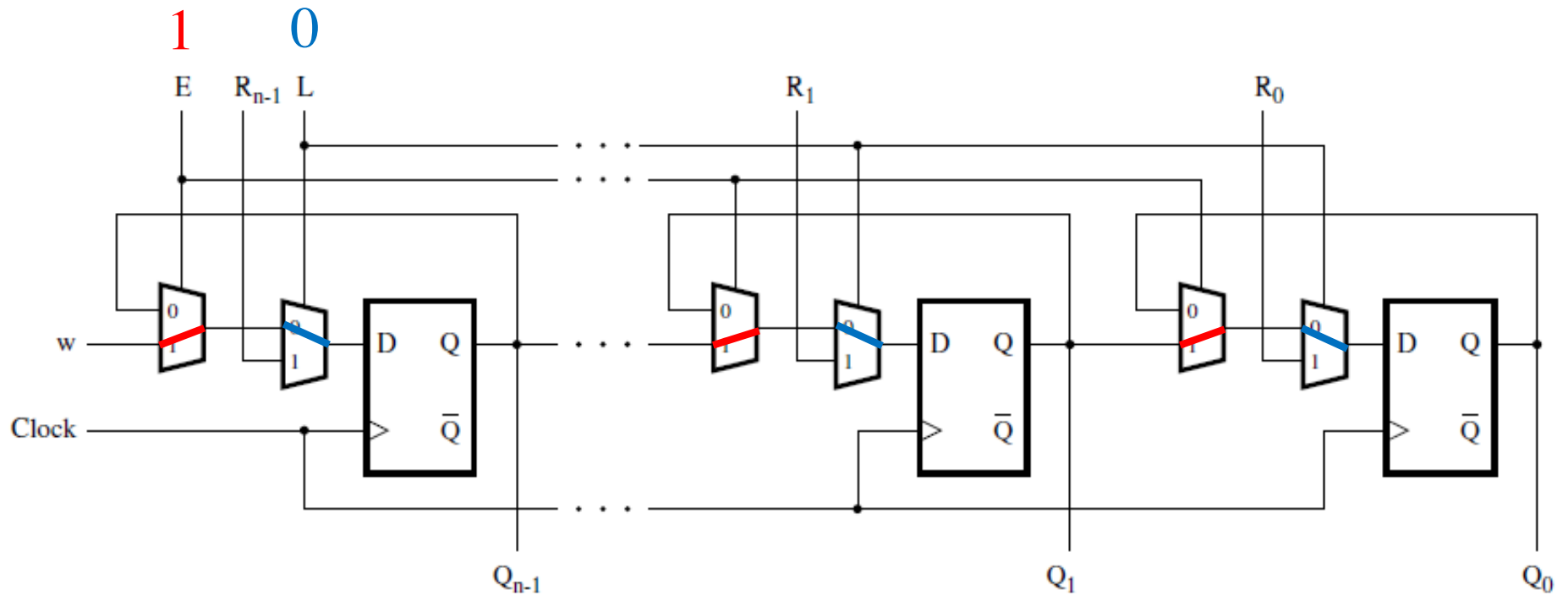

[Figure 5.59 from the textbook]

A shift register with parallel load and enable control inputs

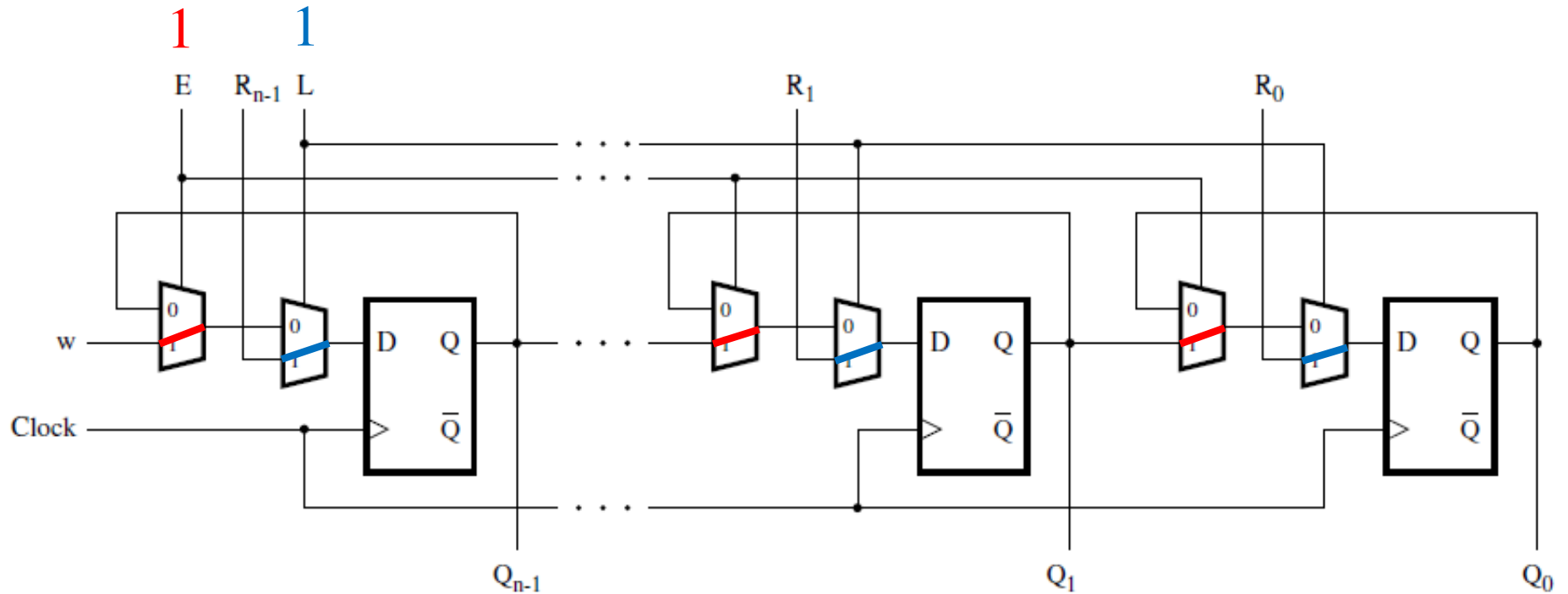

[Figure 5.59 from the textbook]

Parallel-access shift left / right register

Parallel-access shift left/right register

Complete the following circuit diagram to implement a 4-bit register that has both parallel load and shift left/right functionality. The register has two control inputs (C1 and C0), four parallel input lines (I3, I2, I1, and I0), and four output lines (Q3, Q2, Q1, and Q0). Depending on the values of C1 and C0, the register performs one of the following four operations:

C ₁	C ₀	Operation
0	0	Hold the current value (i.e., Q ₃ Q ₂ Q ₁ Q ₀ are not changed)
0	1	Shift left (i.e., new Q ₃ =Q ₂ , new Q ₂ =Q ₁ , new Q ₁ =Q ₀ , new Q ₀ =I ₀)
1	0	Shift right (i.e., new Q ₃ =I ₃ , new Q ₂ =Q ₃ , new Q ₁ =Q ₂ , new Q ₀ =Q ₁)
1	1	Load new data (i.e., new Q ₃ =I ₃ , new Q ₂ =I ₂ , new Q ₁ =I ₁ , new Q ₀ =I ₀)

Parallel-access shift left/right register

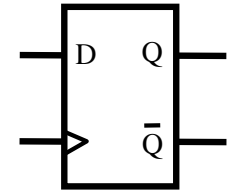
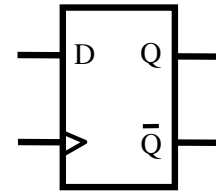
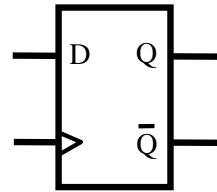
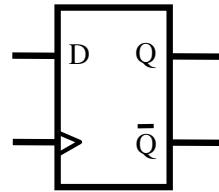

Parallel-access shift left/right register

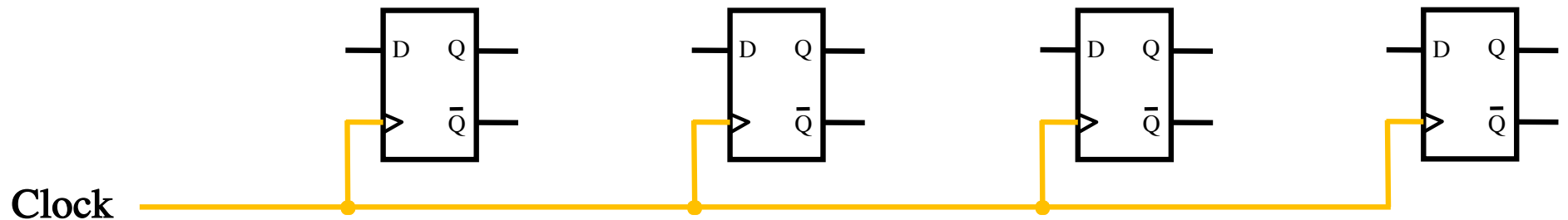

Parallel-access shift left/right register

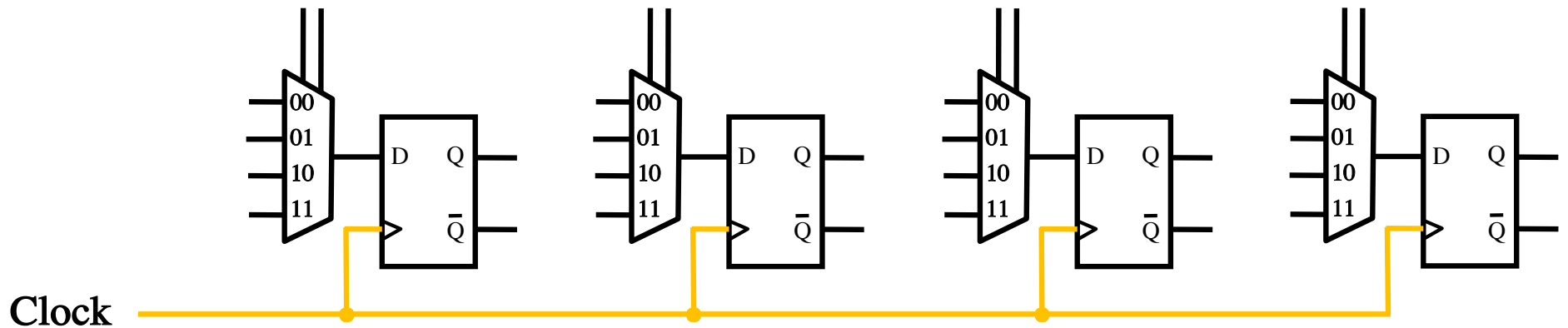

Parallel-access shift left/right register

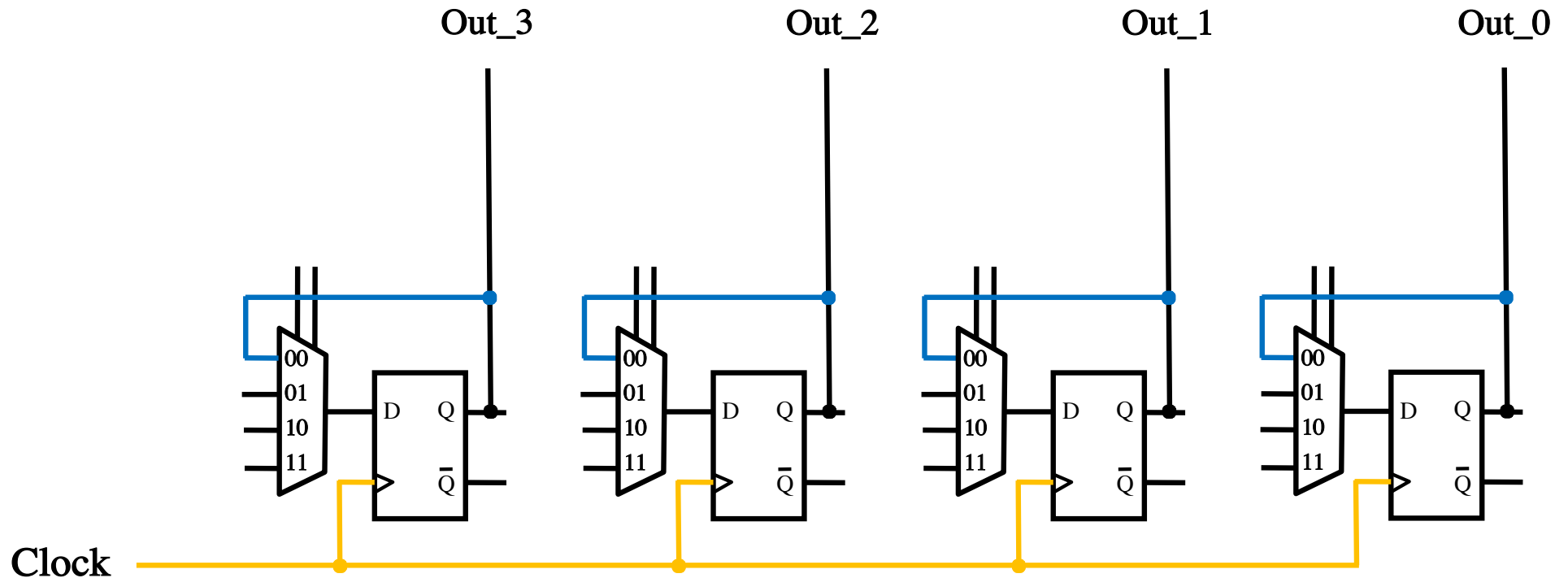

Parallel-access shift left/right register

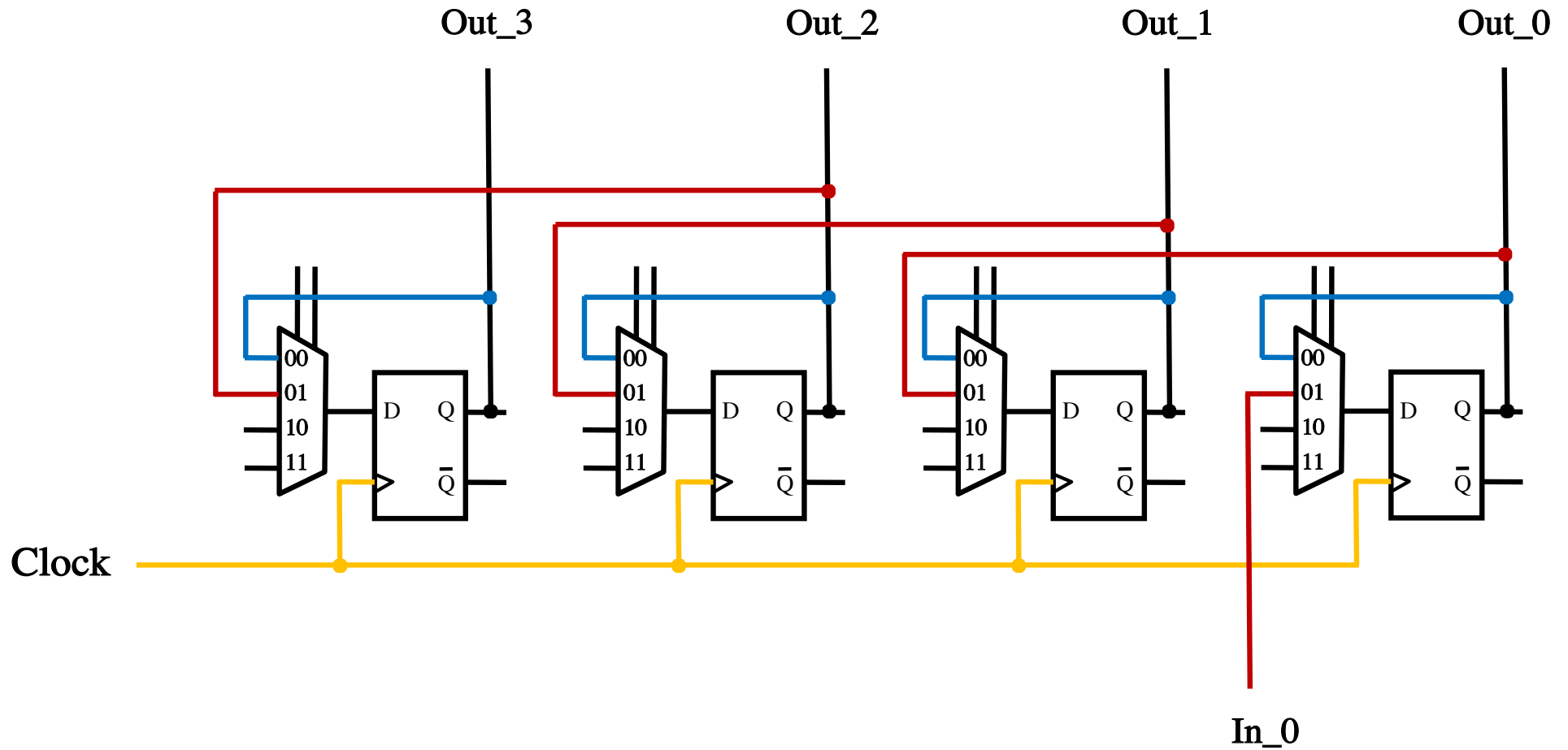

Parallel-access shift left/right register

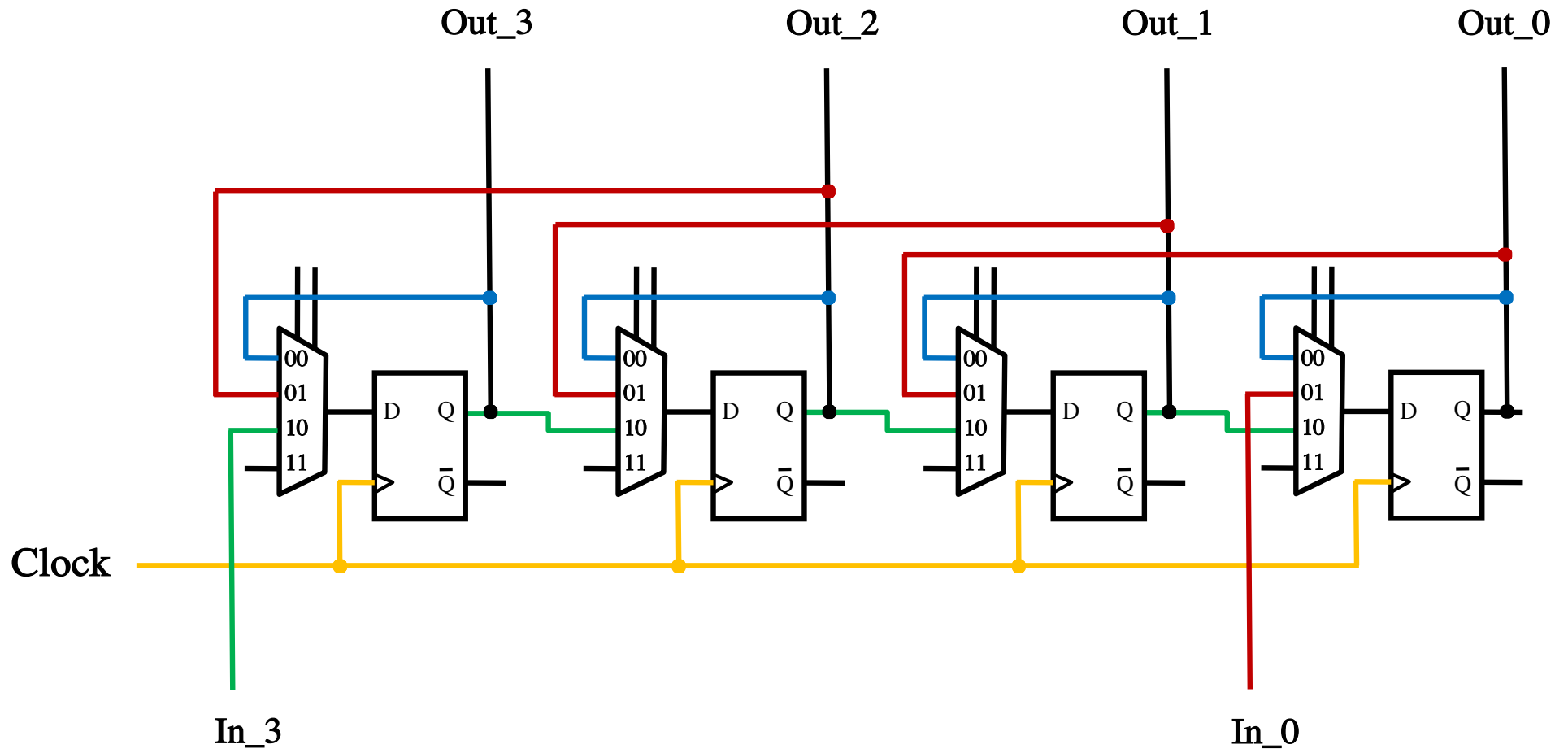

Parallel-access shift left/right register

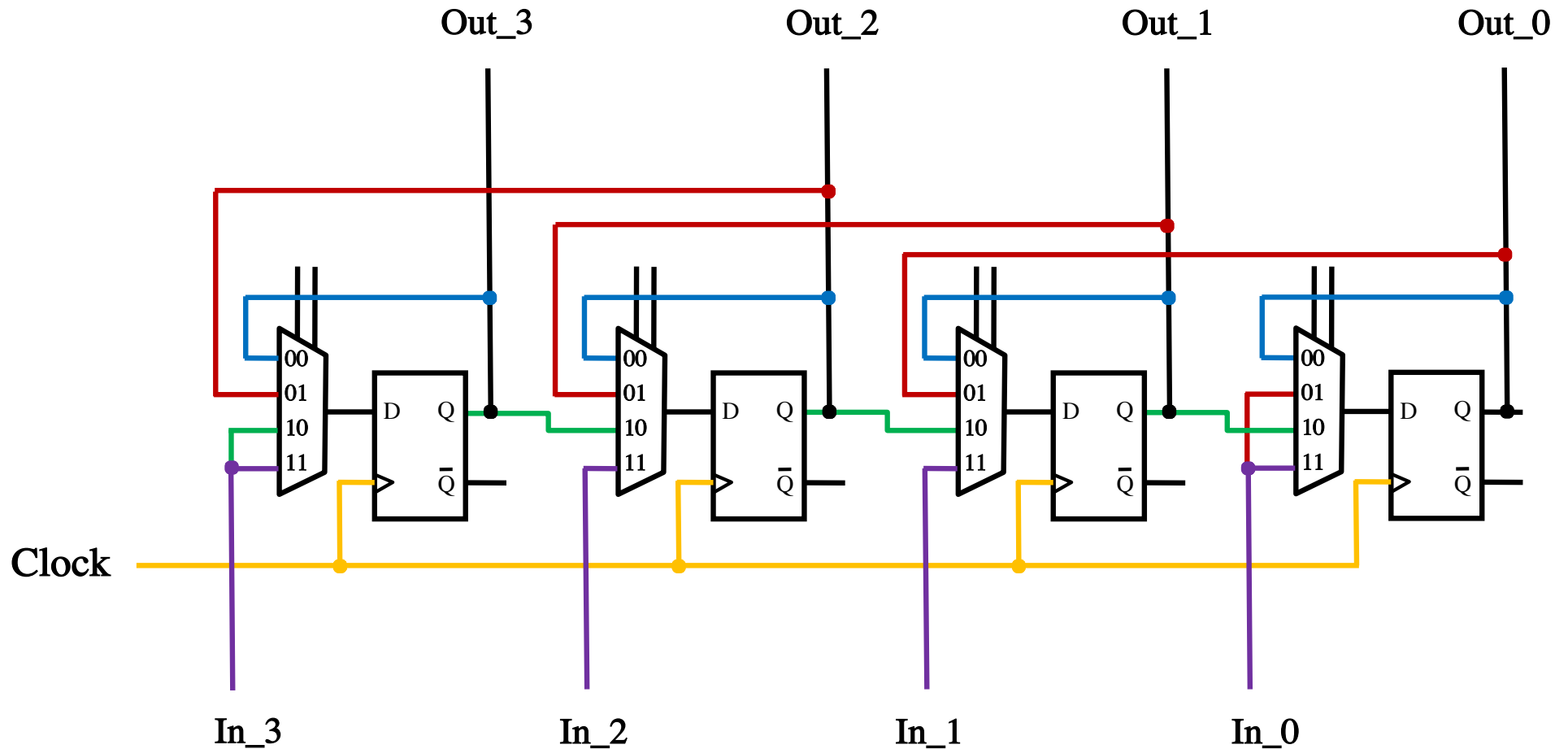

Parallel-access shift left/right register

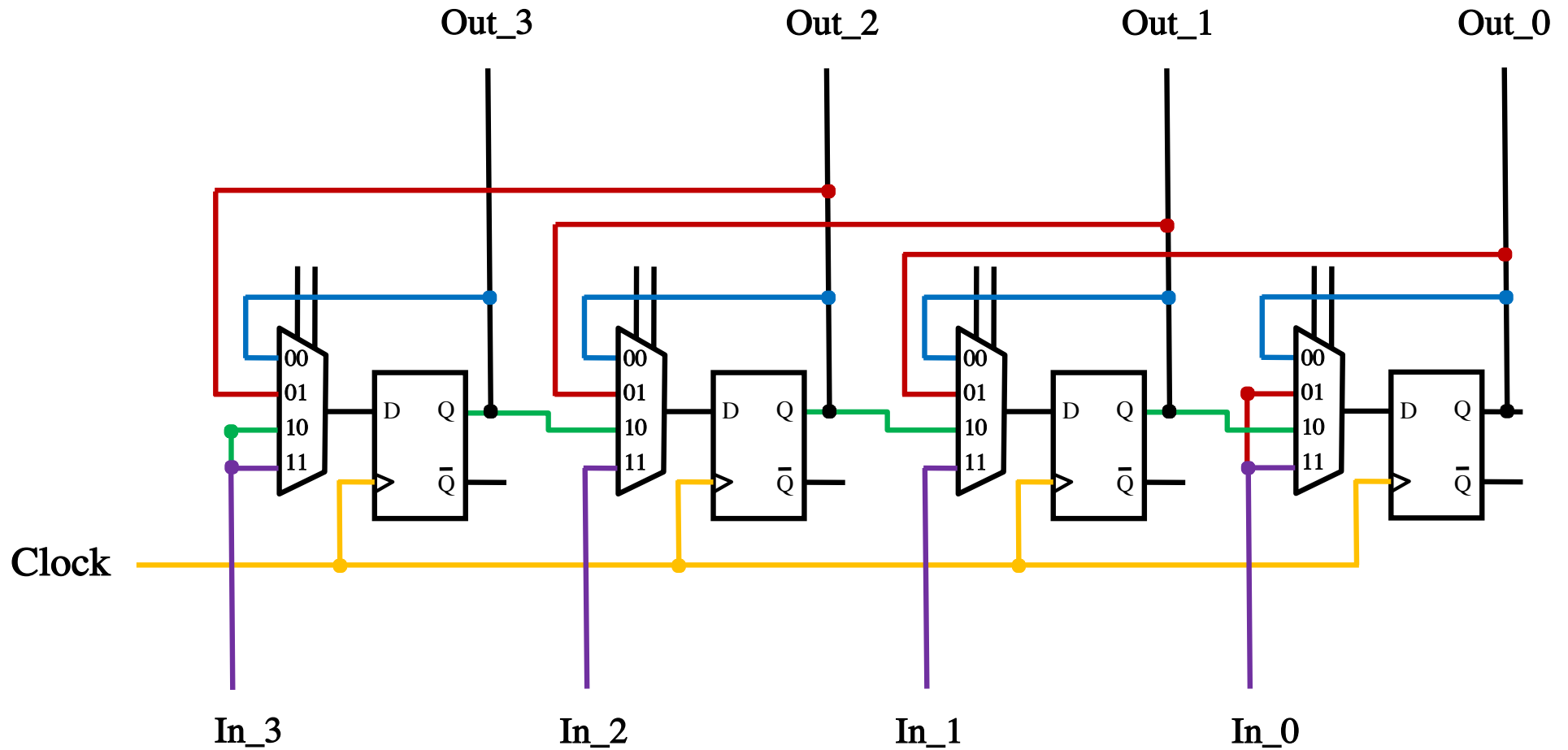

Parallel-access shift left/right register

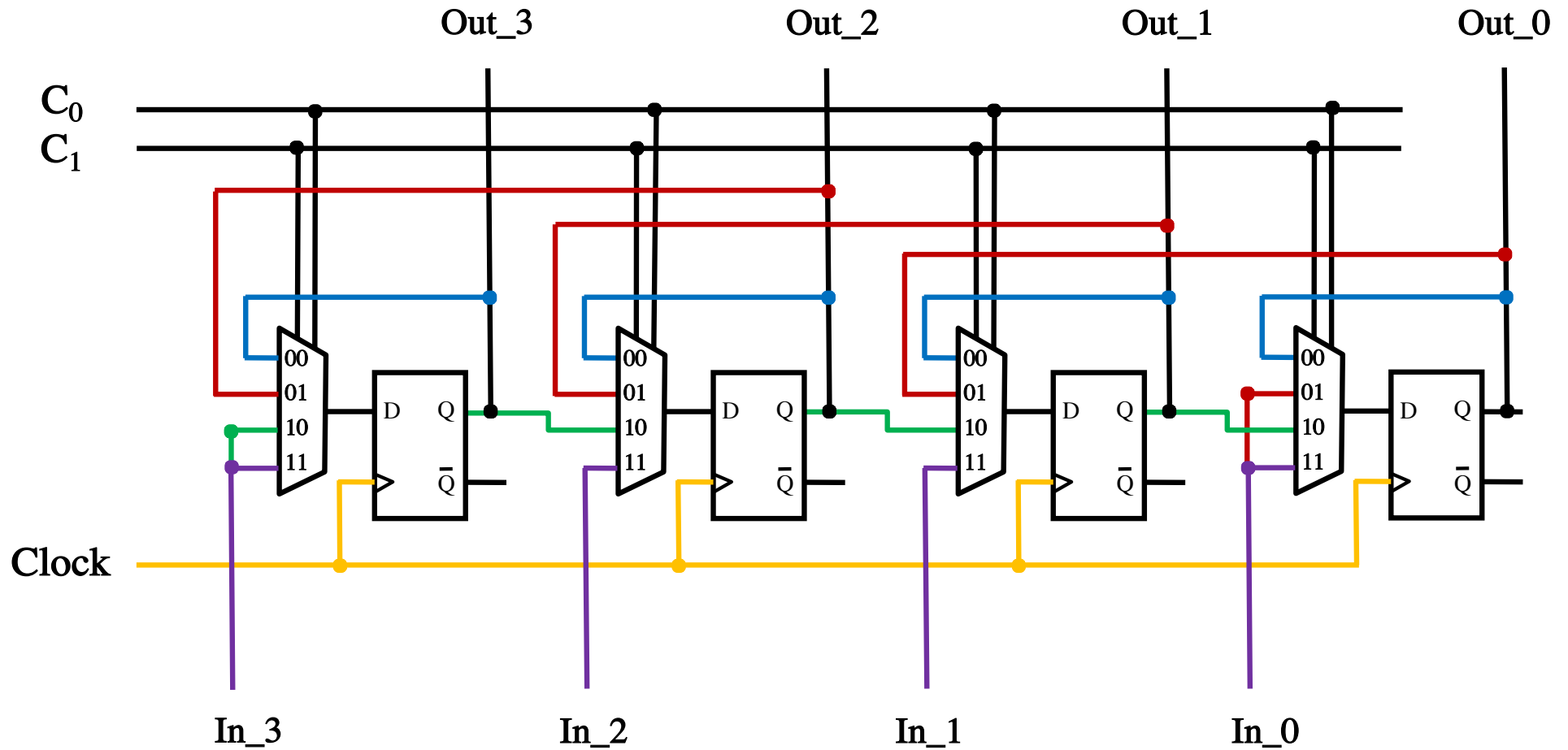

Parallel-access shift left/right register

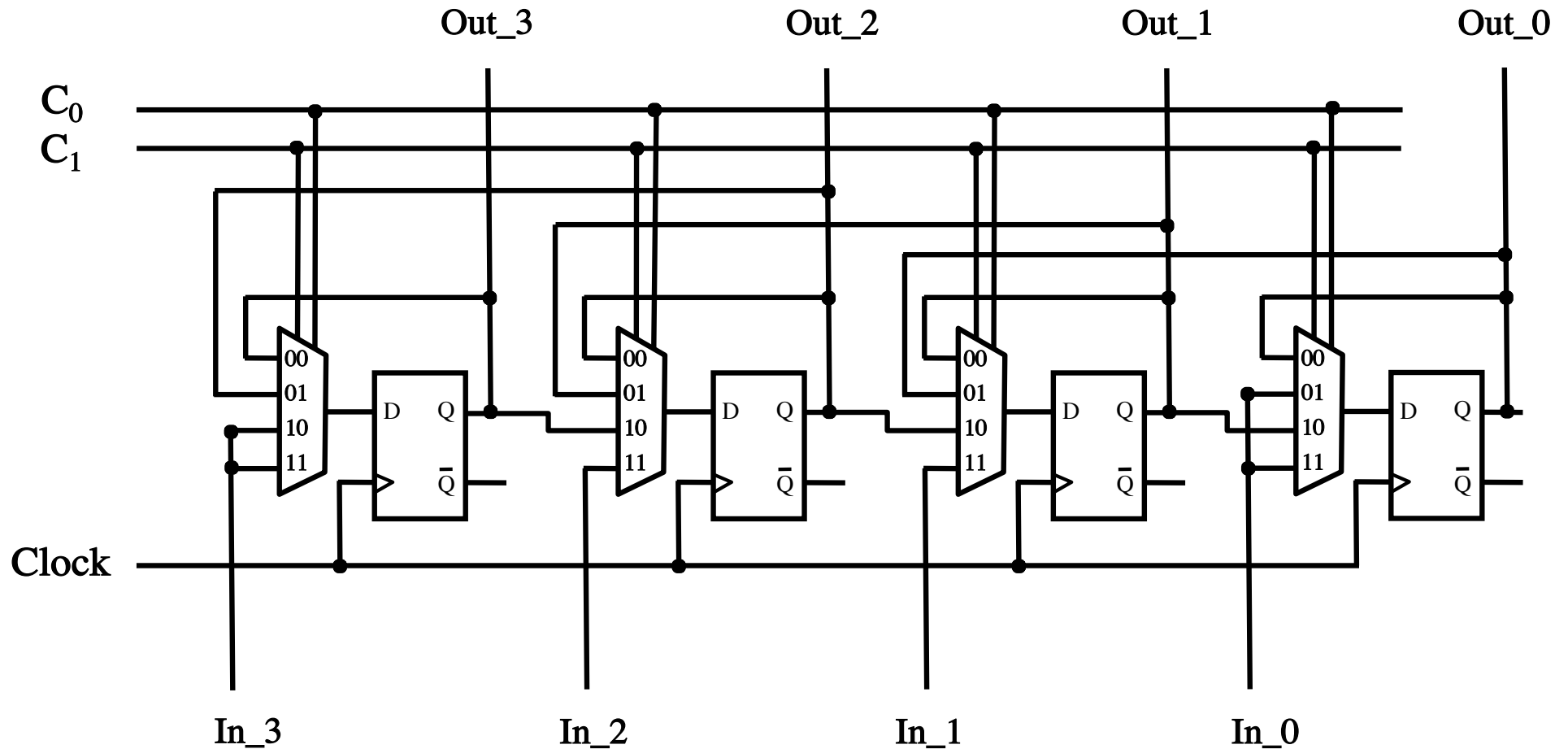

Multiplexer Tricks

(select one of two 2-bit numbers)

Select Either $A=A_1A_0$ or $B=B_1B_0$

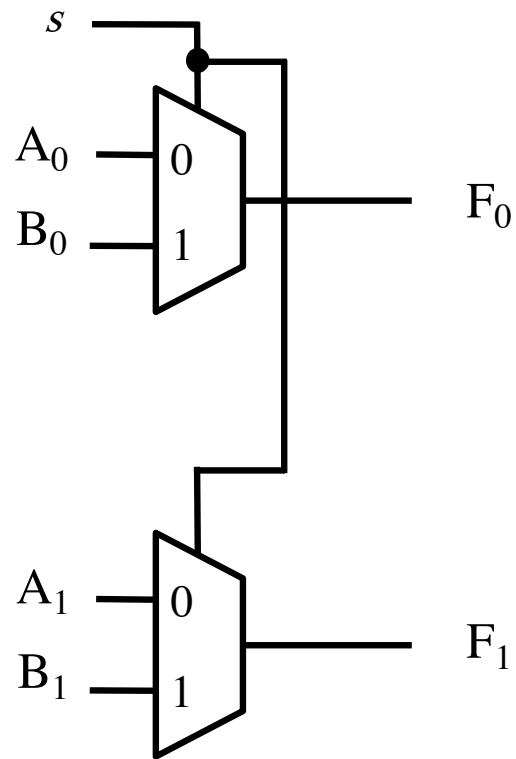

Select Either $A=A_1A_0$ or $B=B_1B_0$

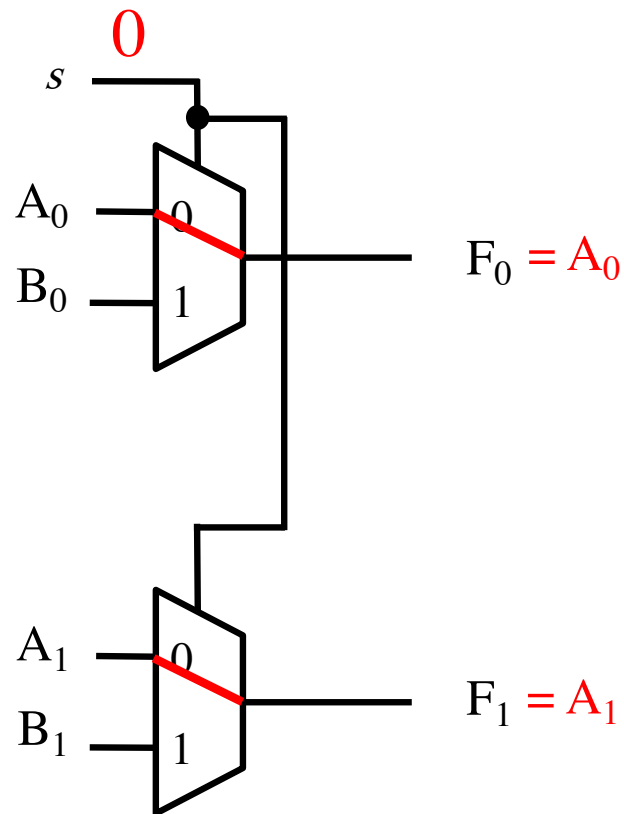

Select Either $A=A_1A_0$ or $B=B_1B_0$

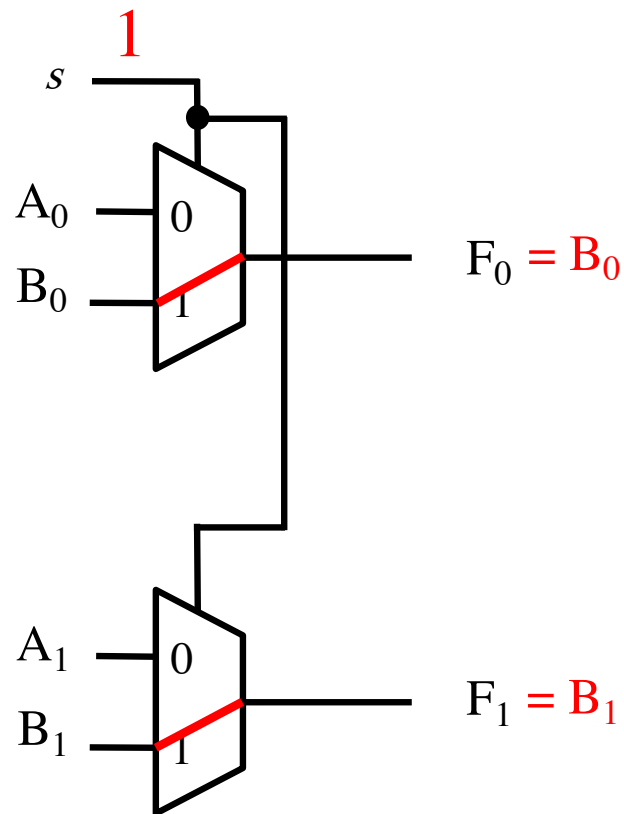

Multiplexer Tricks

(select one of four 2-bit numbers)

Select $A=A_1A_0$ or $B=B_1B_0$ or $C=C_1C_0$ or $D=D_1D_0$

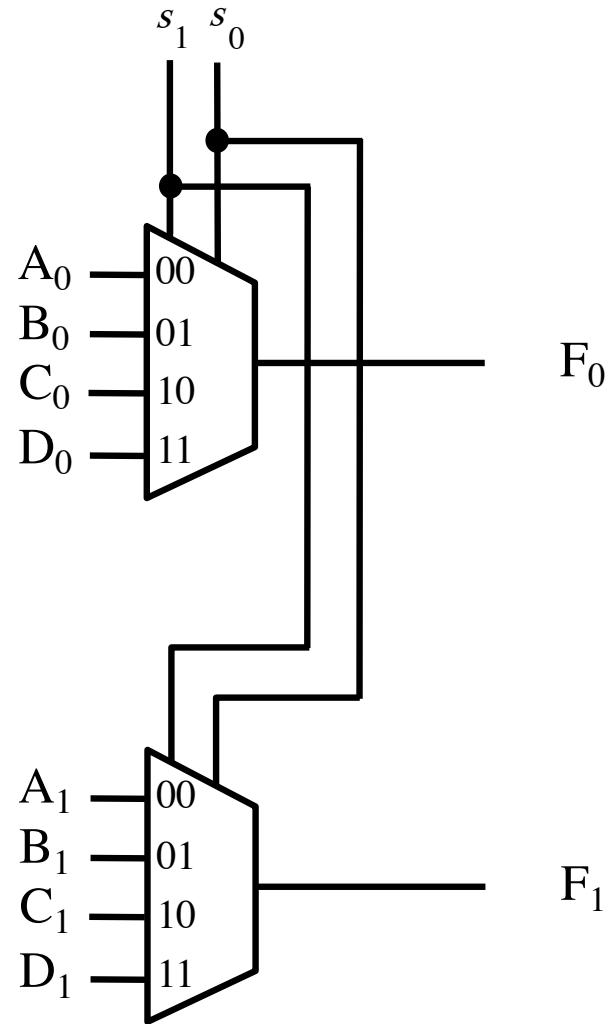

Select $A=A_1A_0$ or $B=B_1B_0$ or $C=C_1C_0$ or $D=D_1D_0$

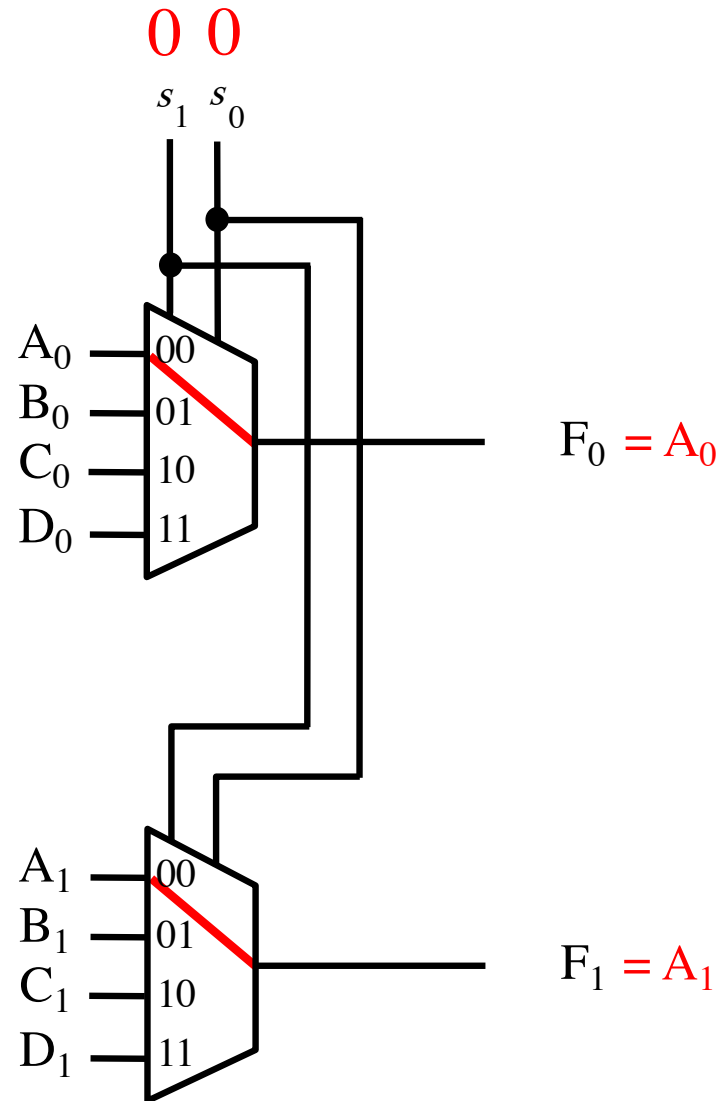

Select $A=A_1A_0$ or $B=B_1B_0$ or $C=C_1C_0$ or $D=D_1D_0$

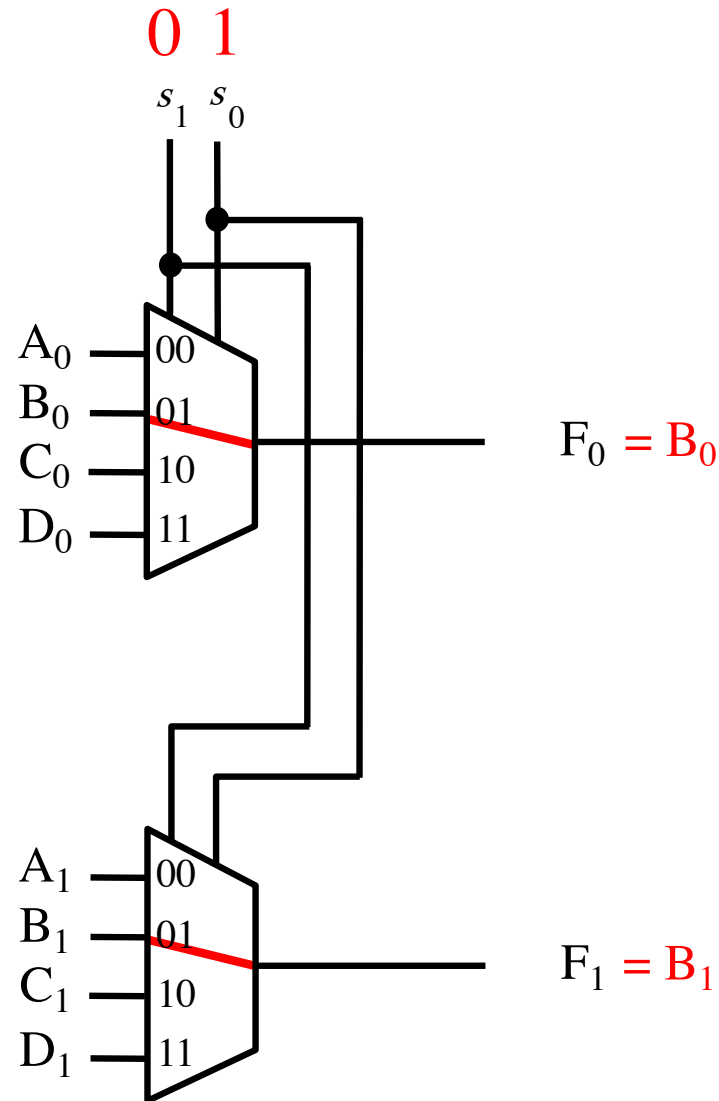

Select $A=A_1A_0$ or $B=B_1B_0$ or $C=C_1C_0$ or $D=D_1D_0$

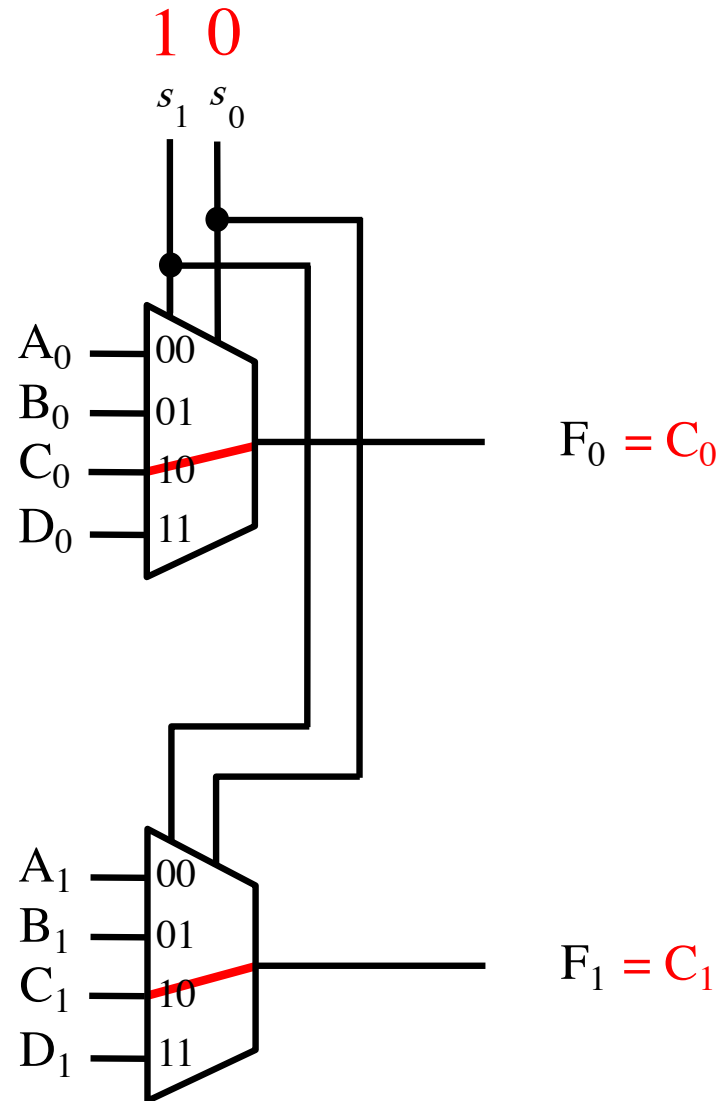

Select $A=A_1A_0$ or $B=B_1B_0$ or $C=C_1C_0$ or $D=D_1D_0$

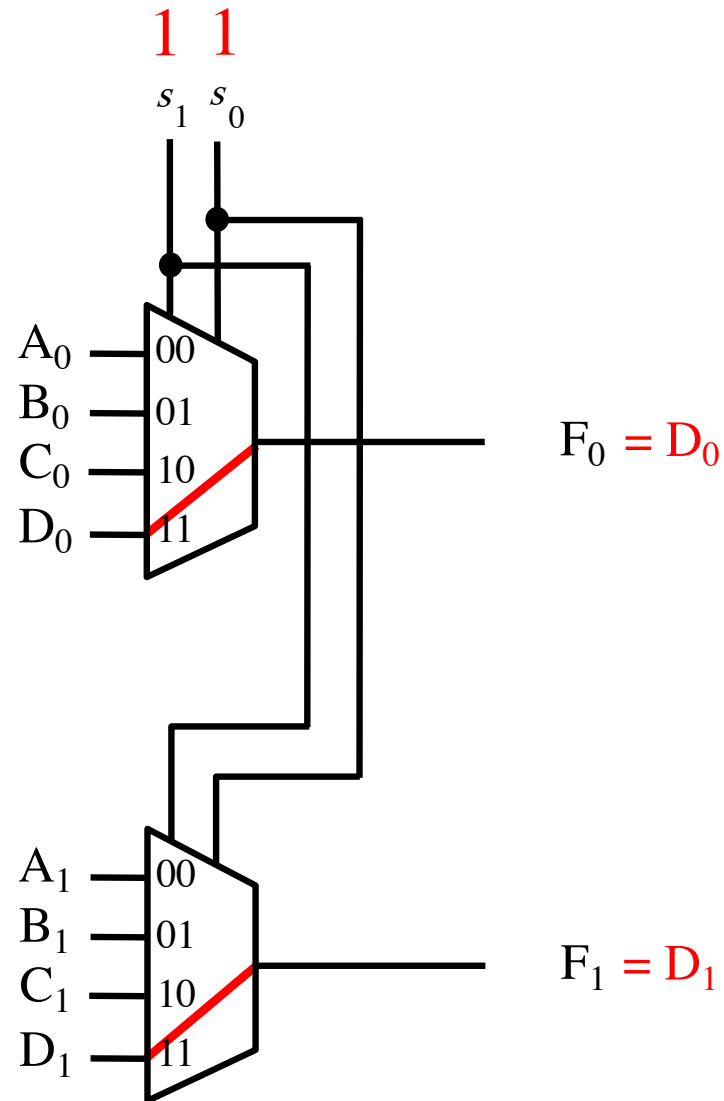

Register File

Complete the following circuit diagram to implement a register file with four 2-bit registers, one write port, one read port, and one write enable line.

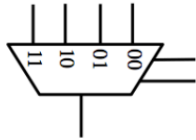
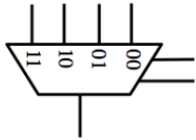
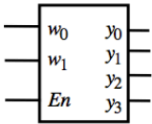
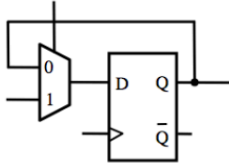
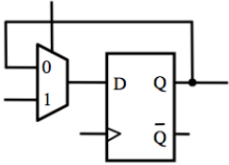
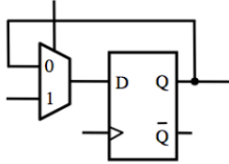
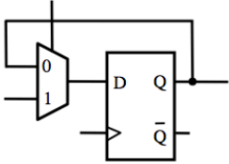
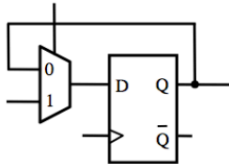
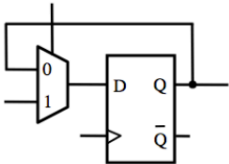
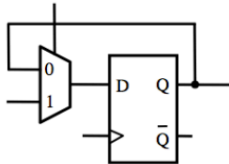
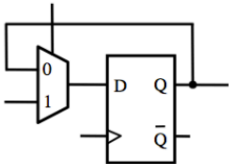

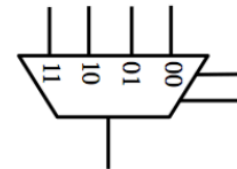
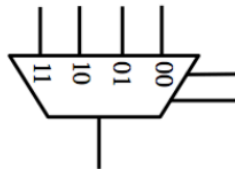
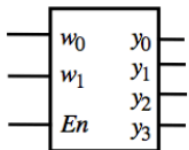
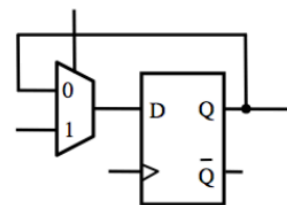
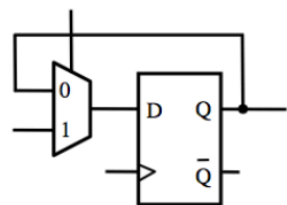
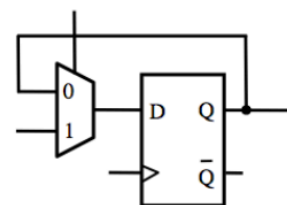
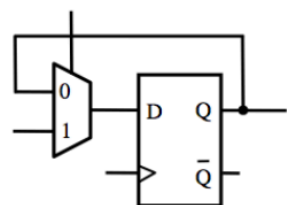
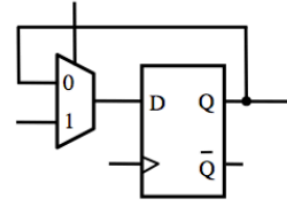
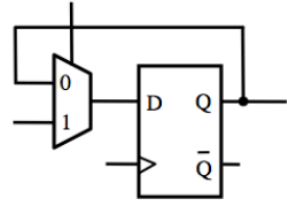
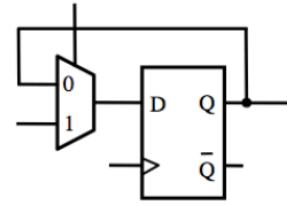
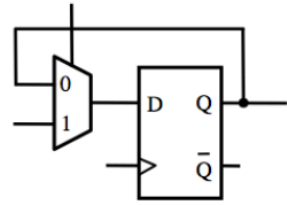

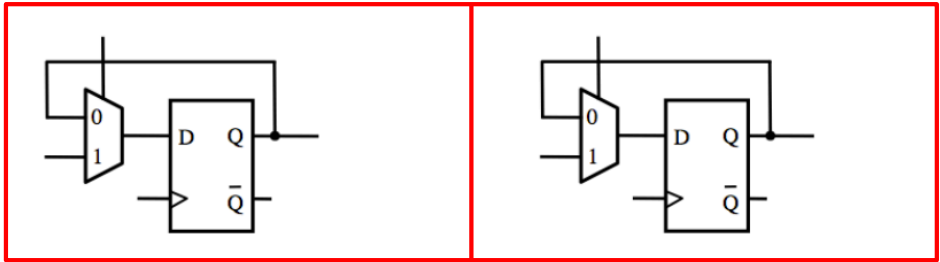

Register 0

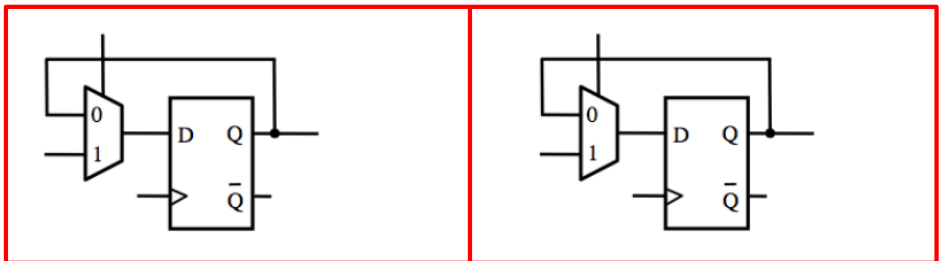

Register 1

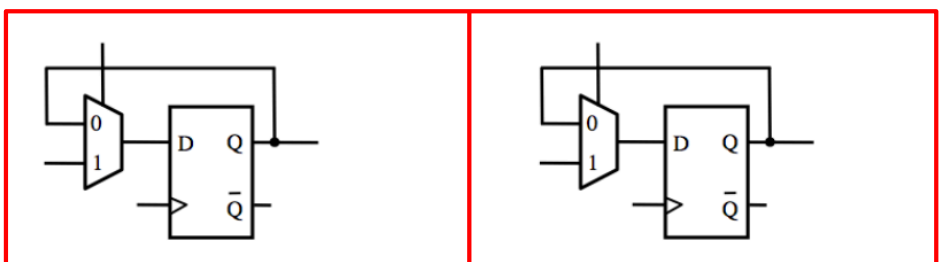

Register 2

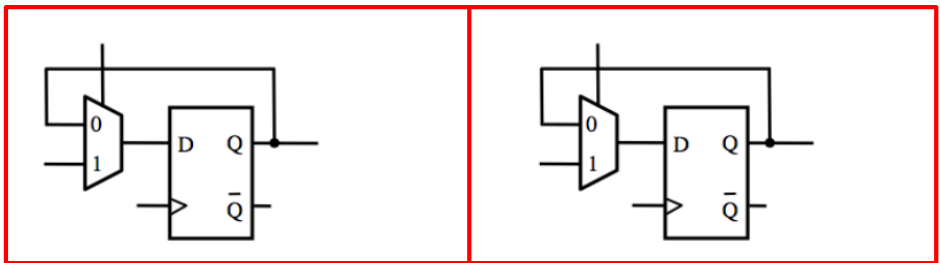

Register 3

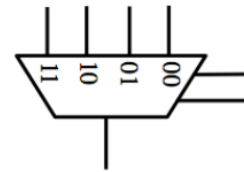
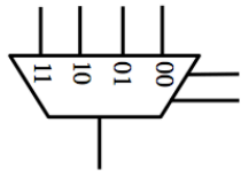
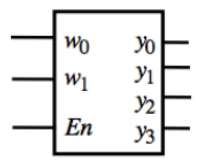

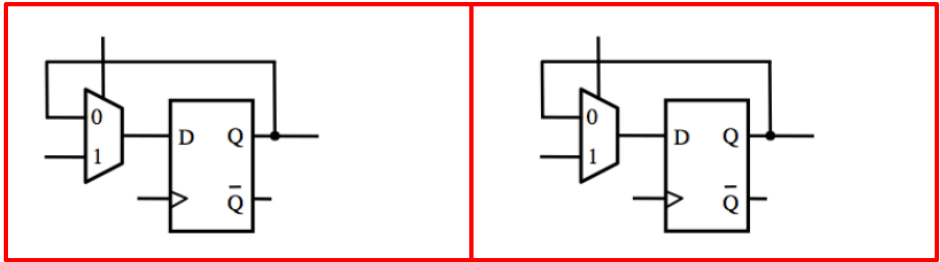

Register A

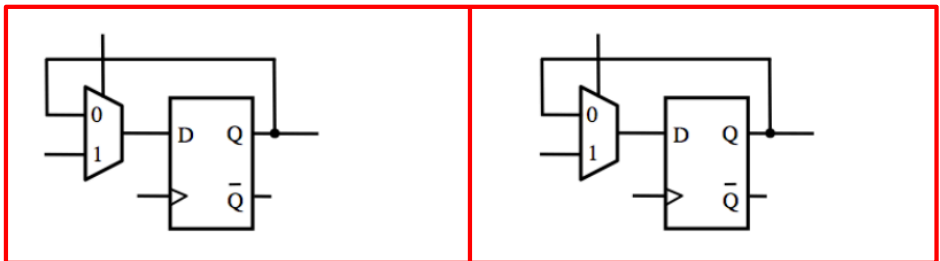

Register B

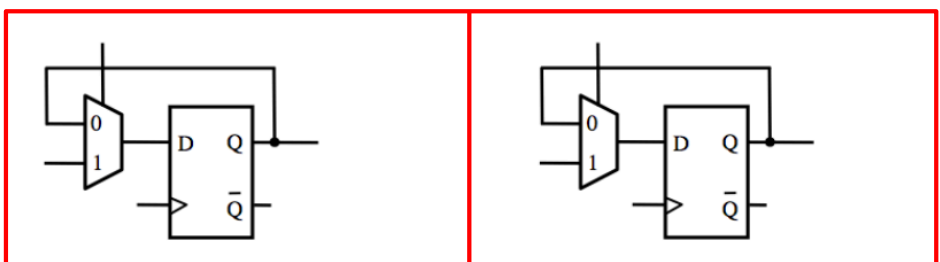

Register C

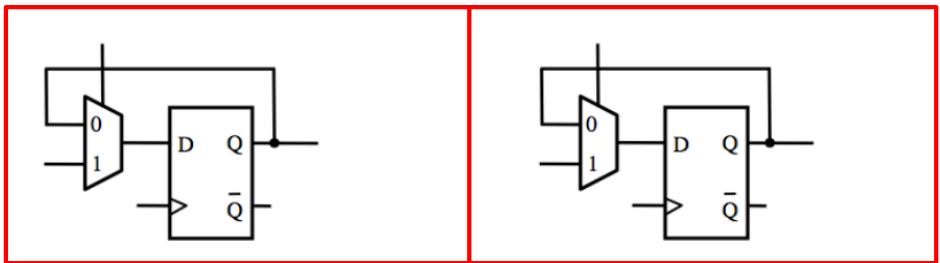

Register D

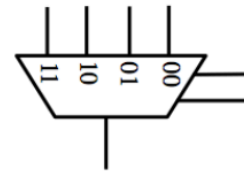
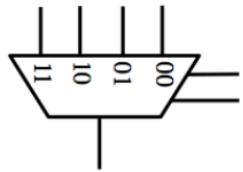
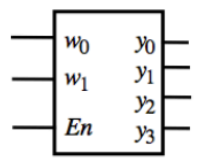

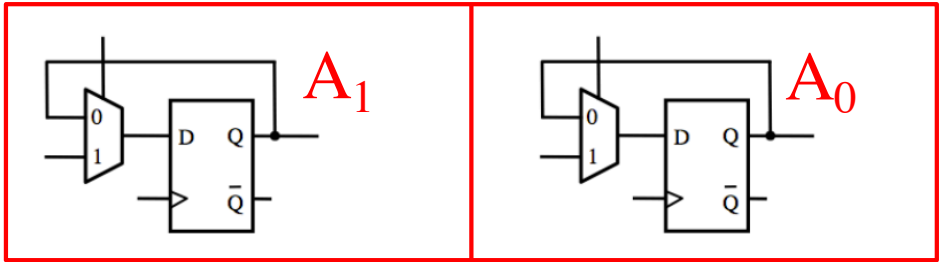

Register A

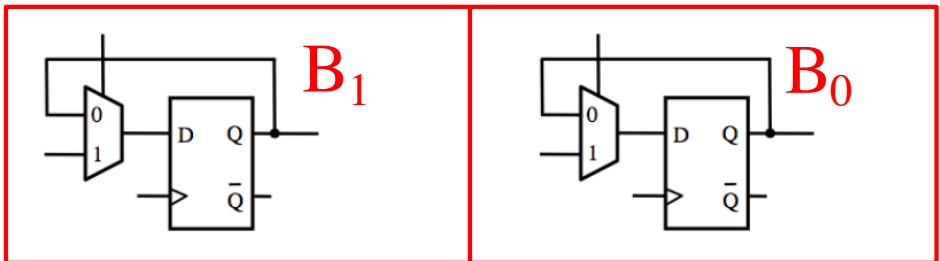

Register B

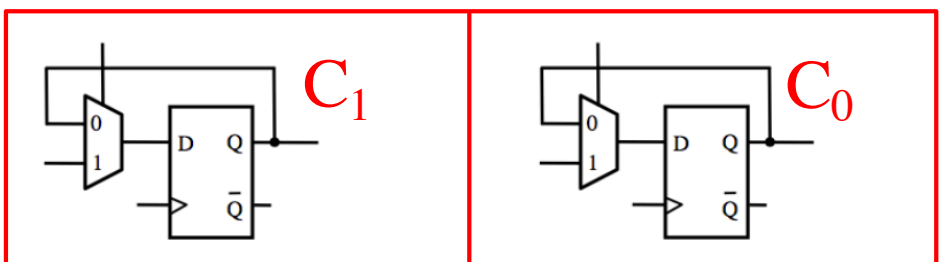

Register C

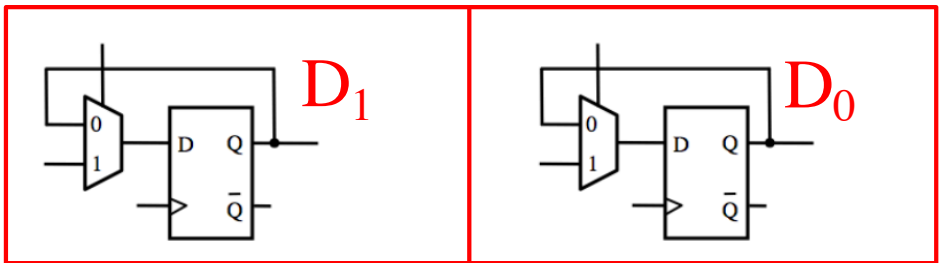

Register D

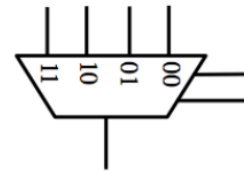
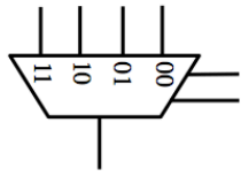
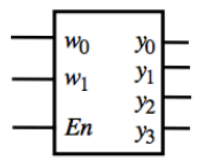

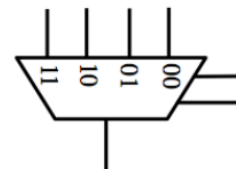
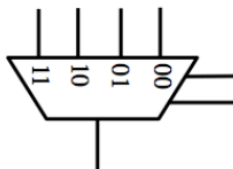
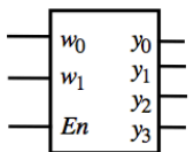
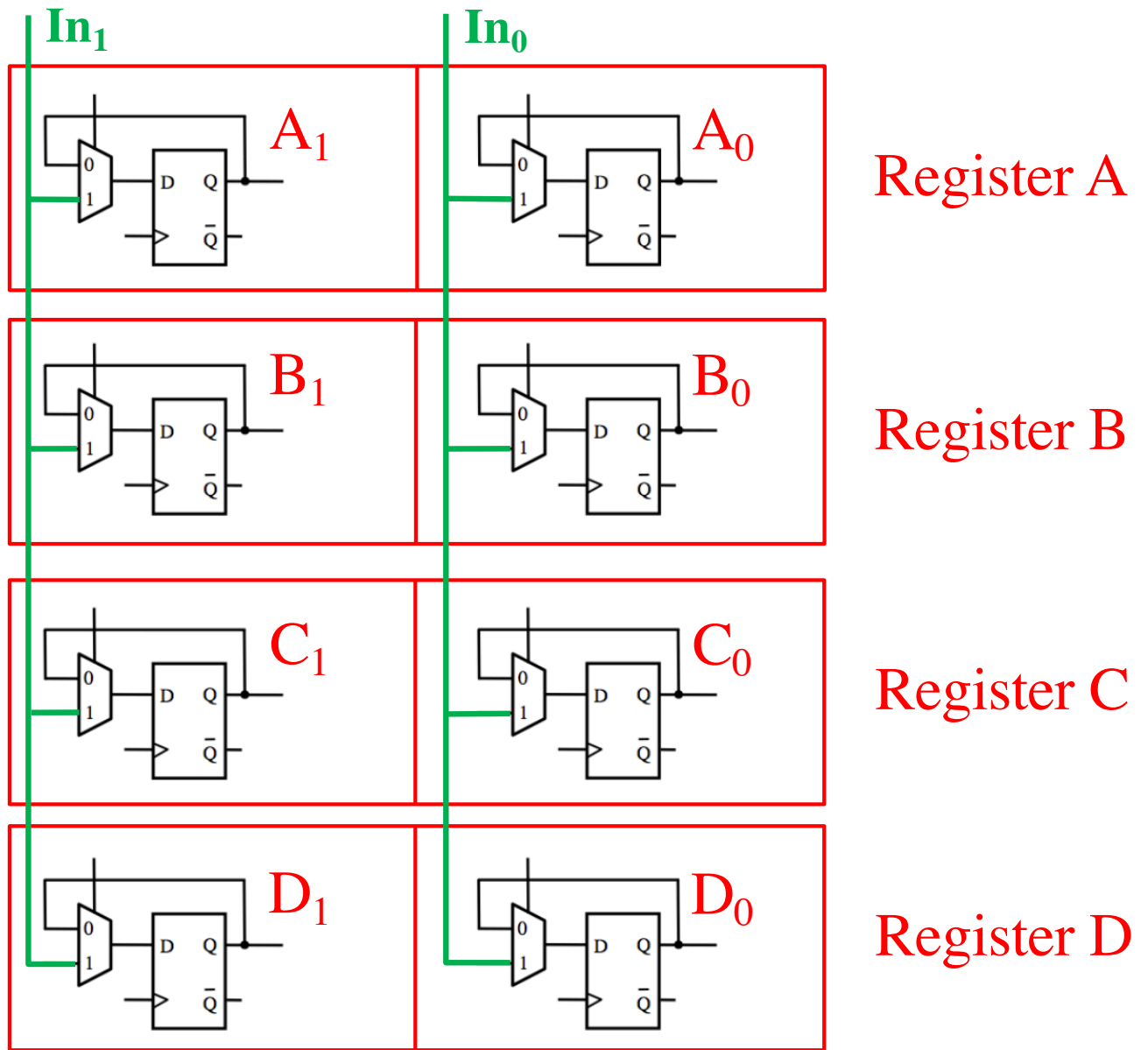

In₁

In₀

A₁

A₀

Register A

B₁

B₀

Register B

C₁

C₀

Register C

D₁

D₀

Register D

Write_address_0
Write_address_1
Write_enable

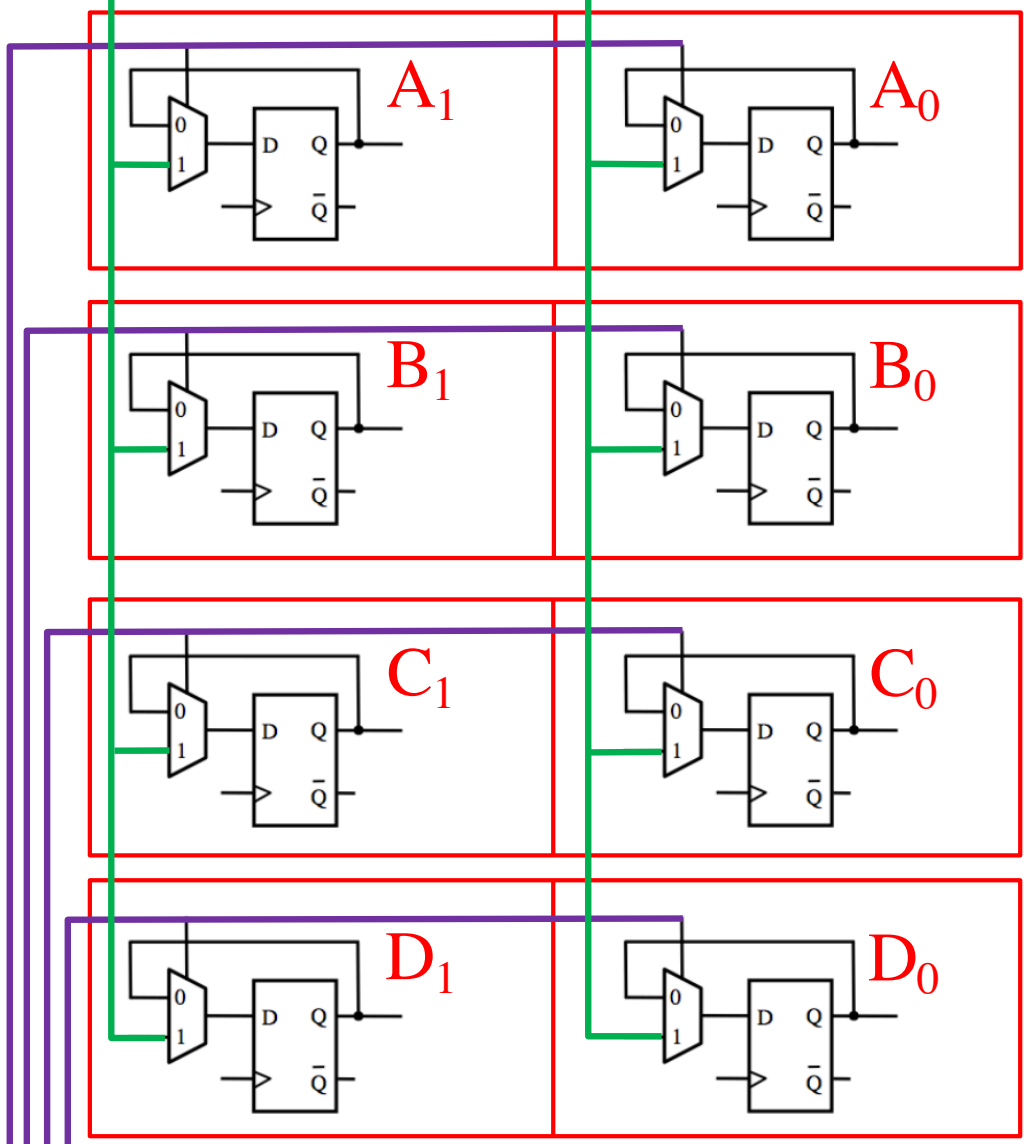
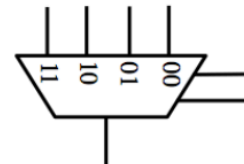
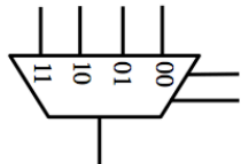
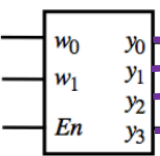

In₁

In₀

A₁

A₀

Register A

B₁

B₀

Register B

C₁

C₀

Register C

D₁

D₀

Register D

Write_address_0
Write_address_1
Write_enable

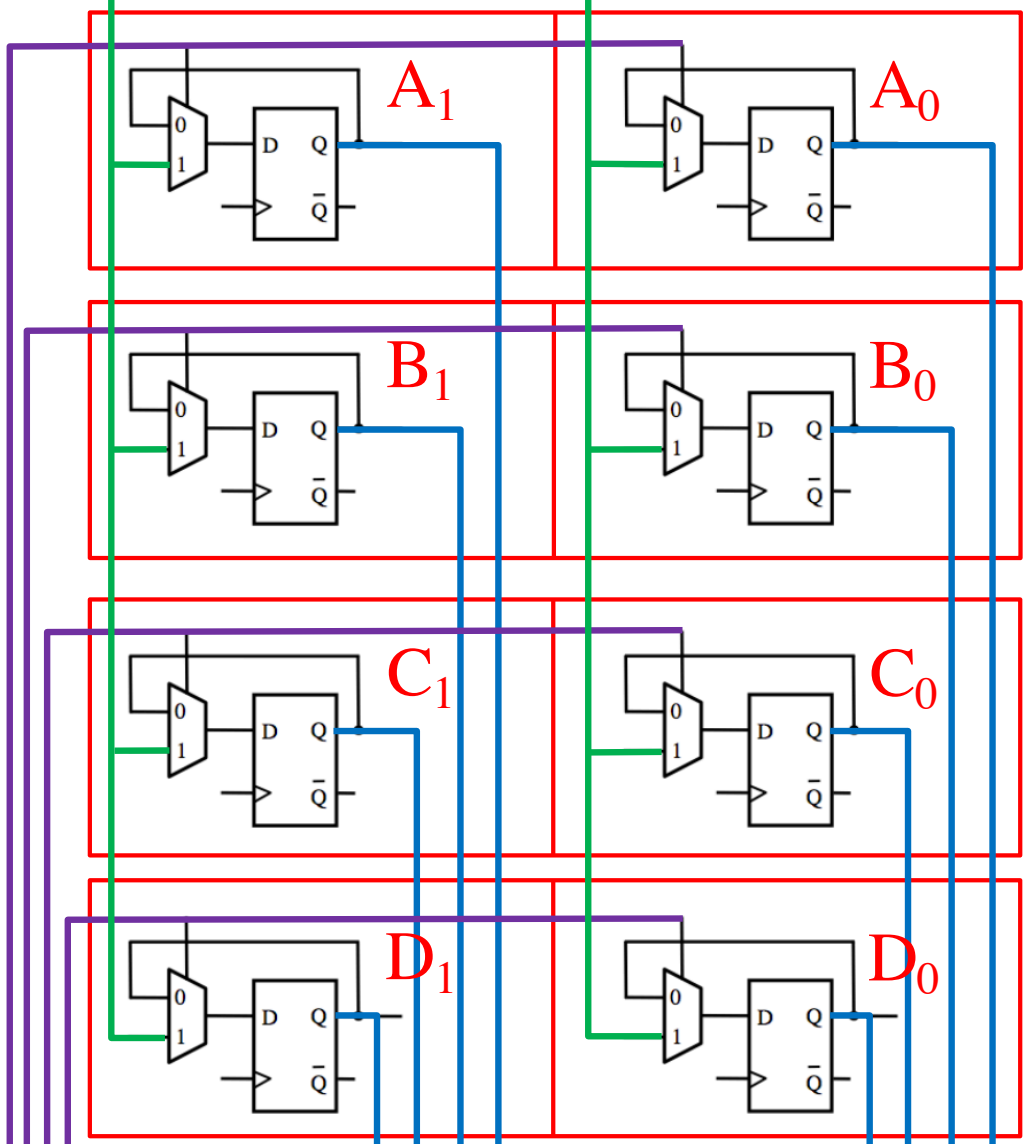
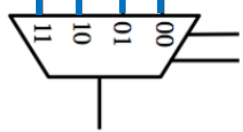
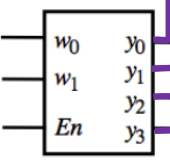

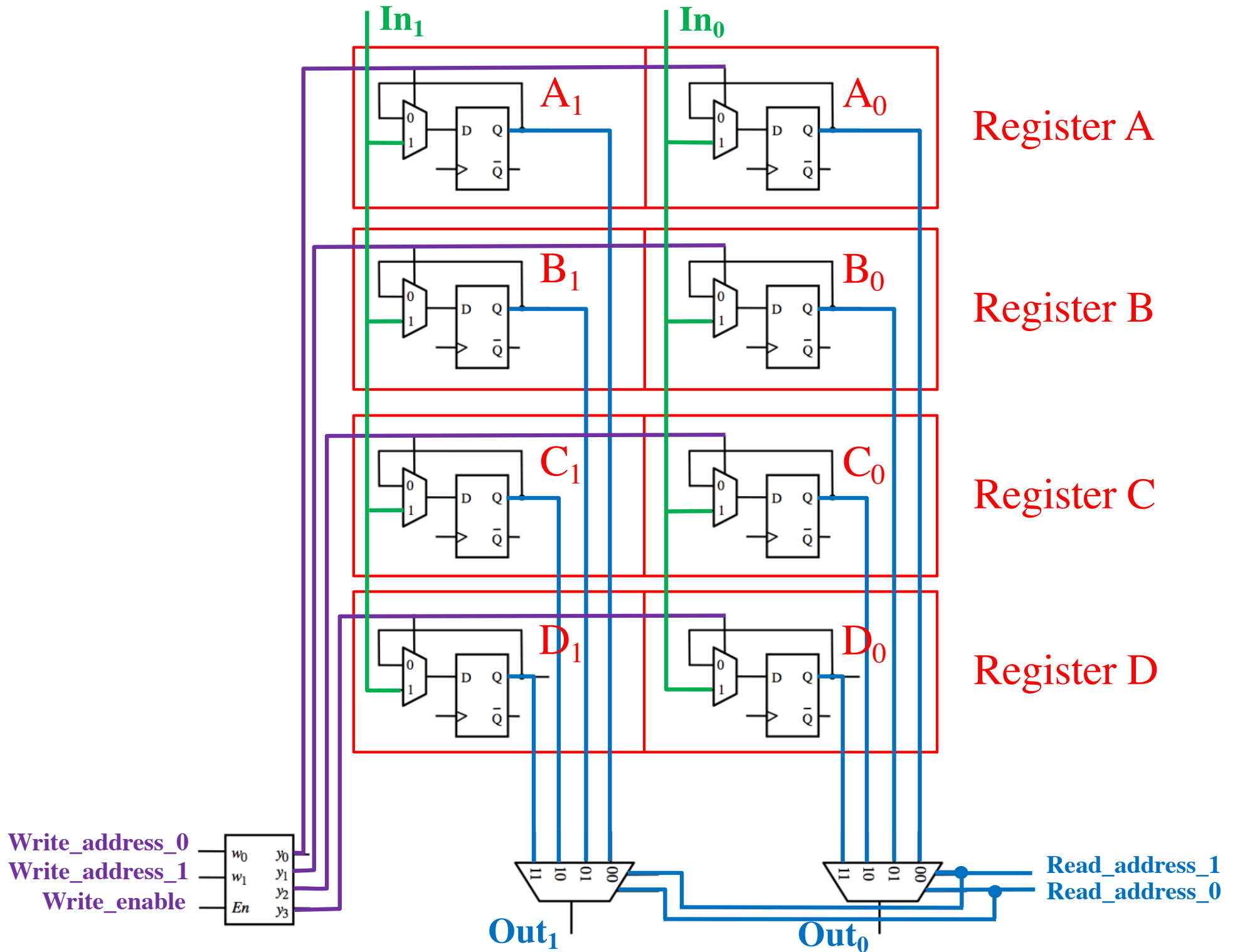

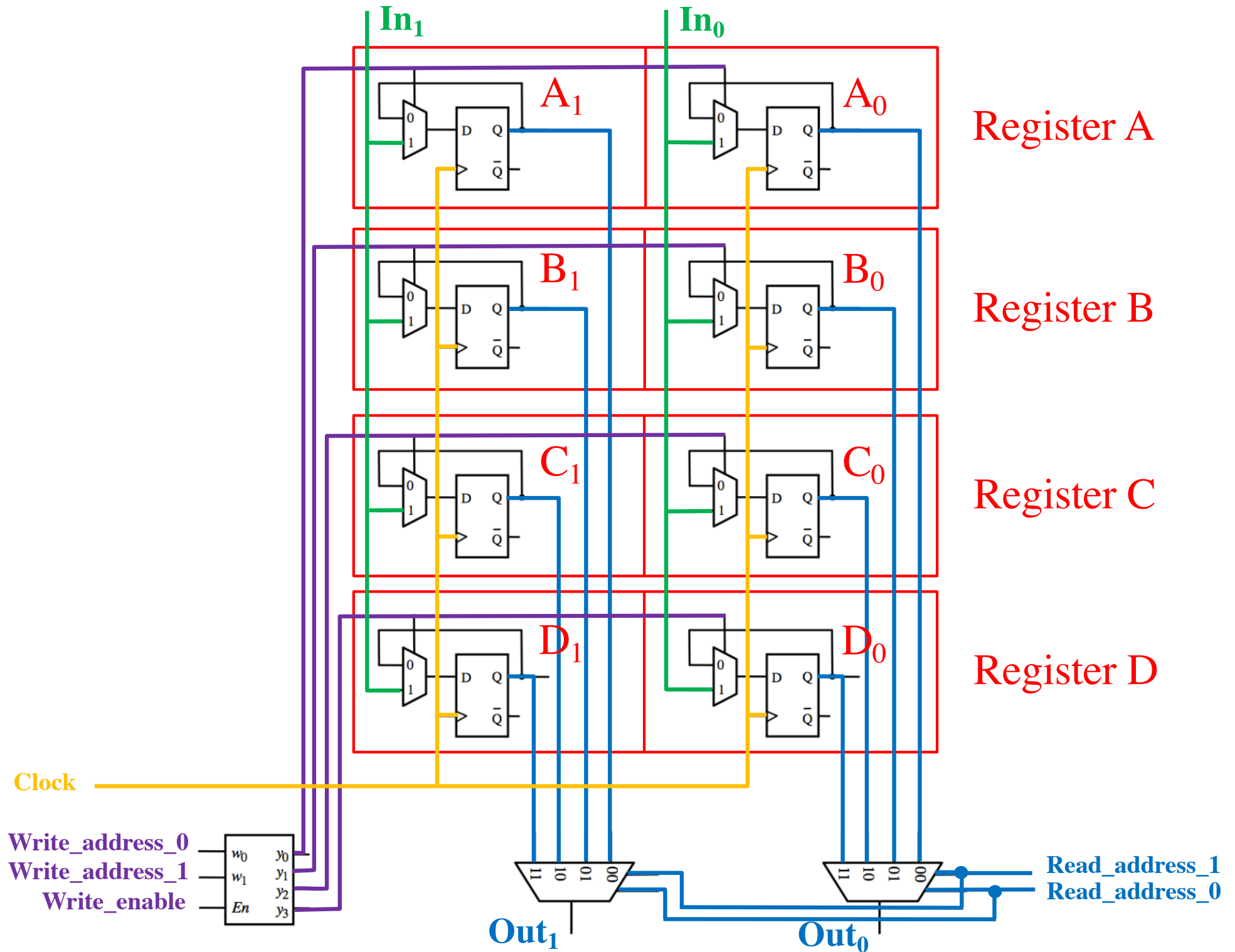

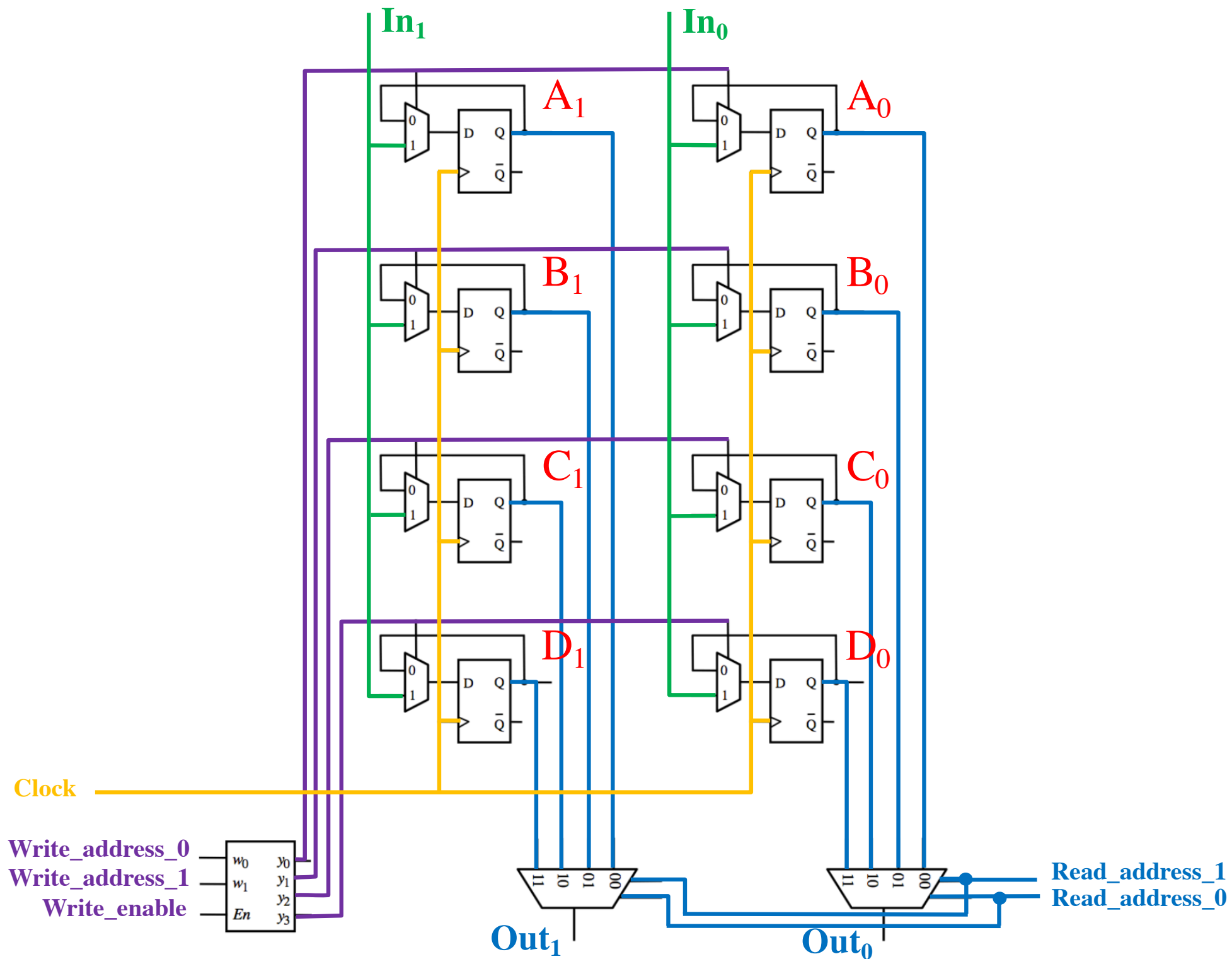

Questions?

THE END