



CprE 281: Digital Logic

Instructor: Alexander Stoytchev

<http://www.ece.iastate.edu/~alexs/classes/>

Intro to Verilog

*CprE 281: Digital Logic
Iowa State University, Ames, IA
Copyright © Alexander Stoytchev*

Administrative Stuff

- **HW3 is due on Monday Sep 12 @ 10p**

Administrative Stuff

- **Sample homework solutions are posted on Canvas**
- **Look under 'Files'**

Quick Review

The Three Basic Logic Gates

x	NOT
0	1
1	0

x	y	AND
0	0	0
0	1	0
1	0	0
1	1	1

x	y	OR
0	0	0
0	1	1
1	0	1
1	1	1

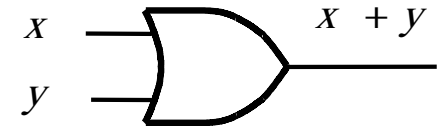
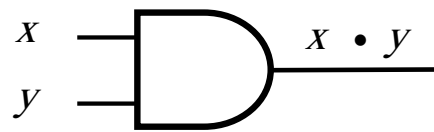
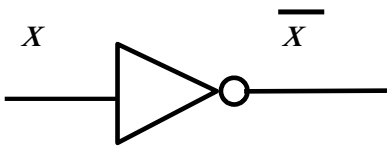

AND with Switches

AND Circuit

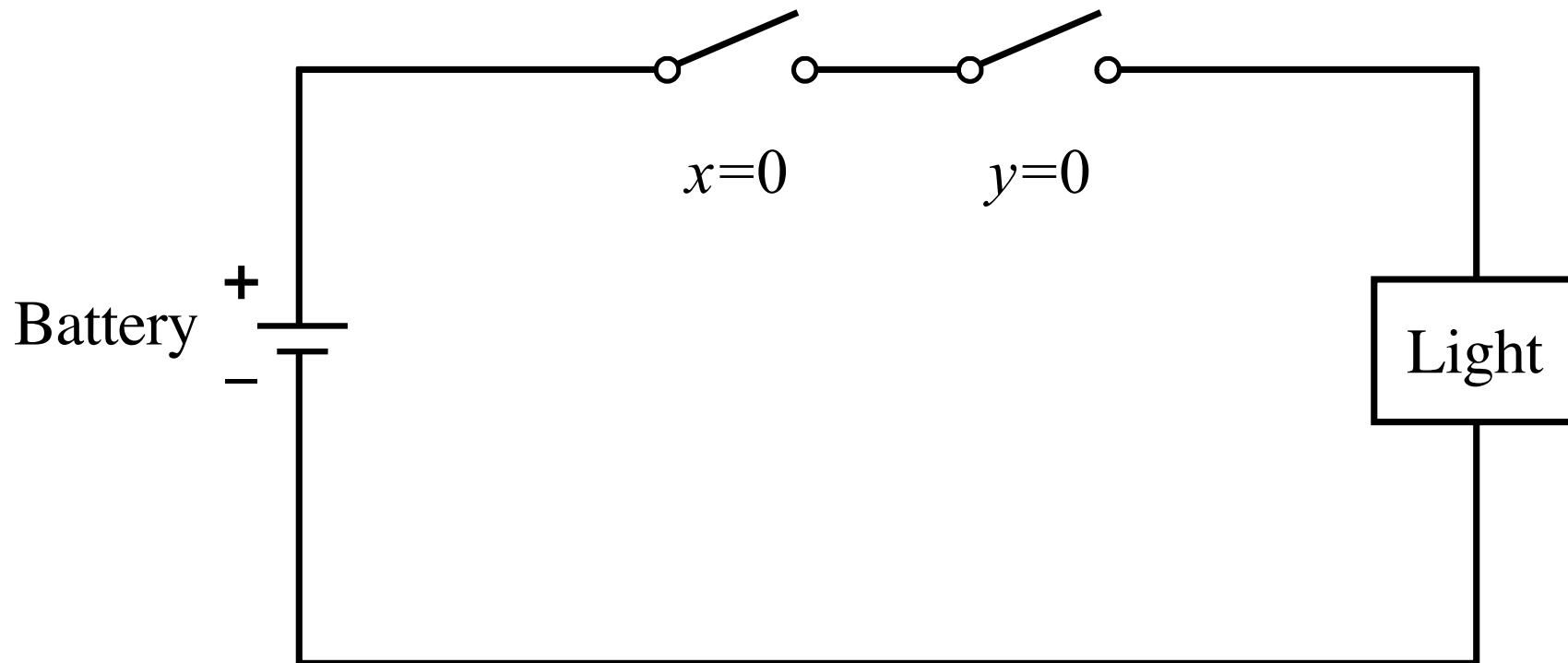

AND Circuit

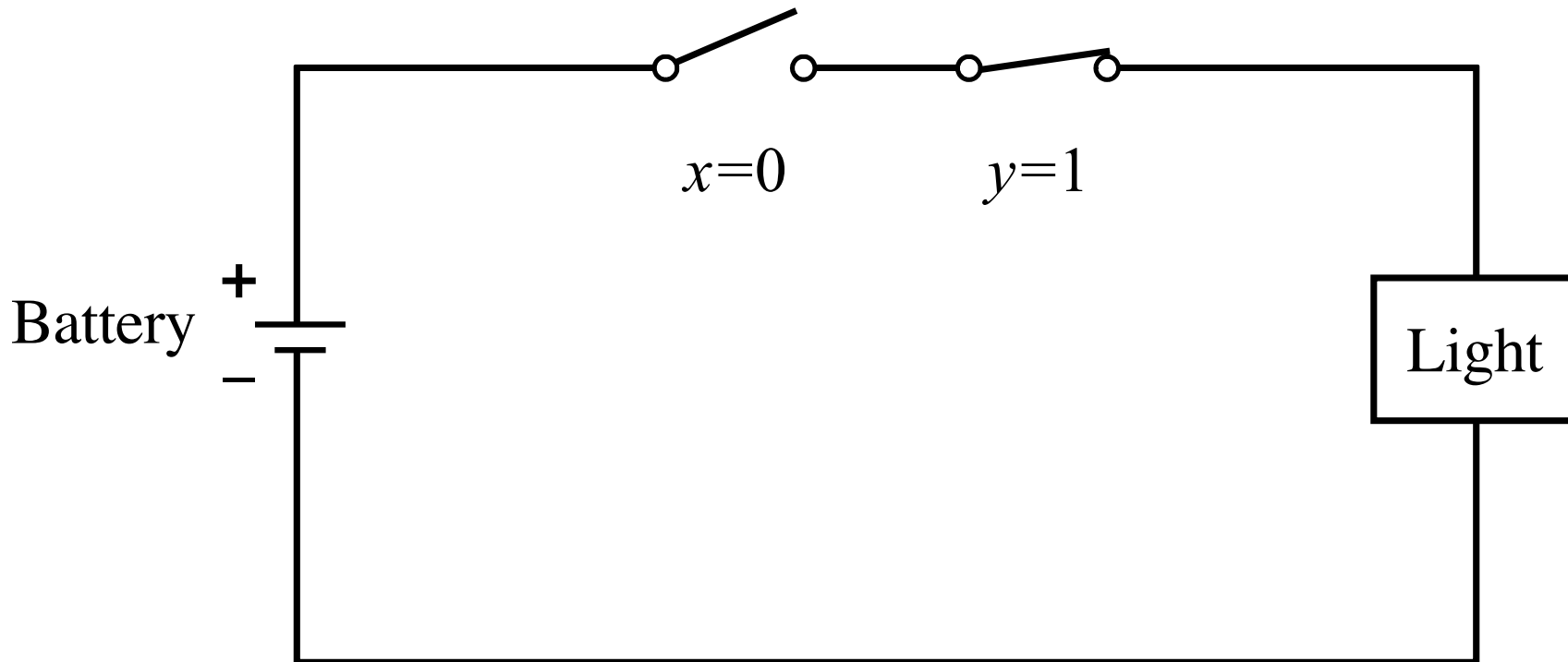

AND Circuit

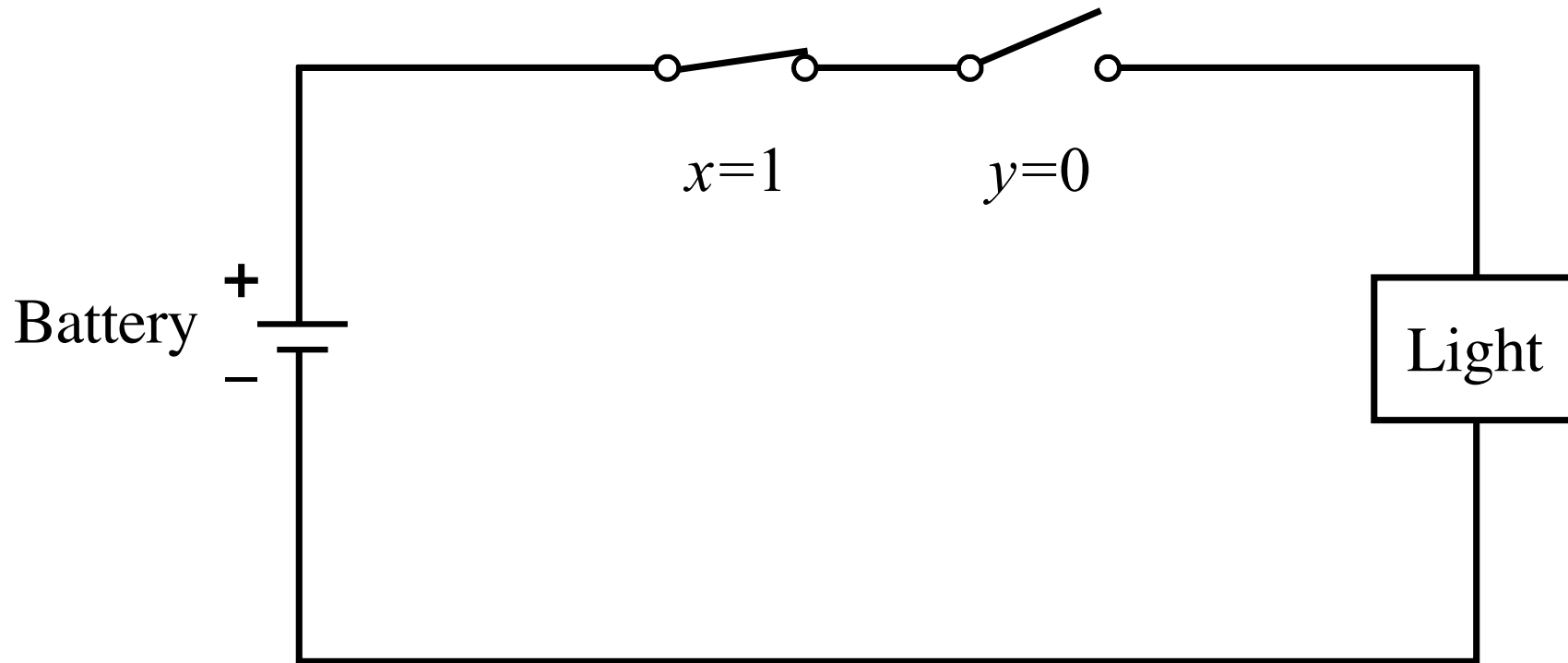

AND Circuit

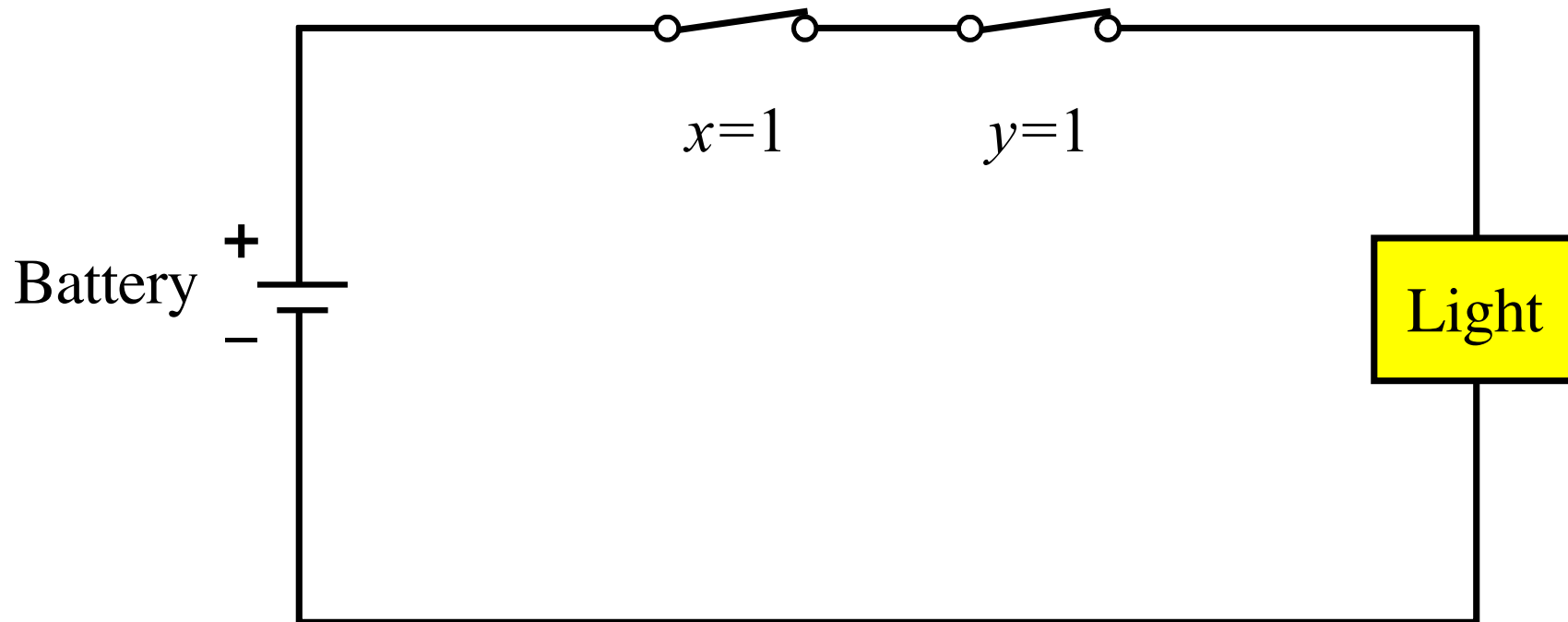

NOT with Switches

NOT Circuit

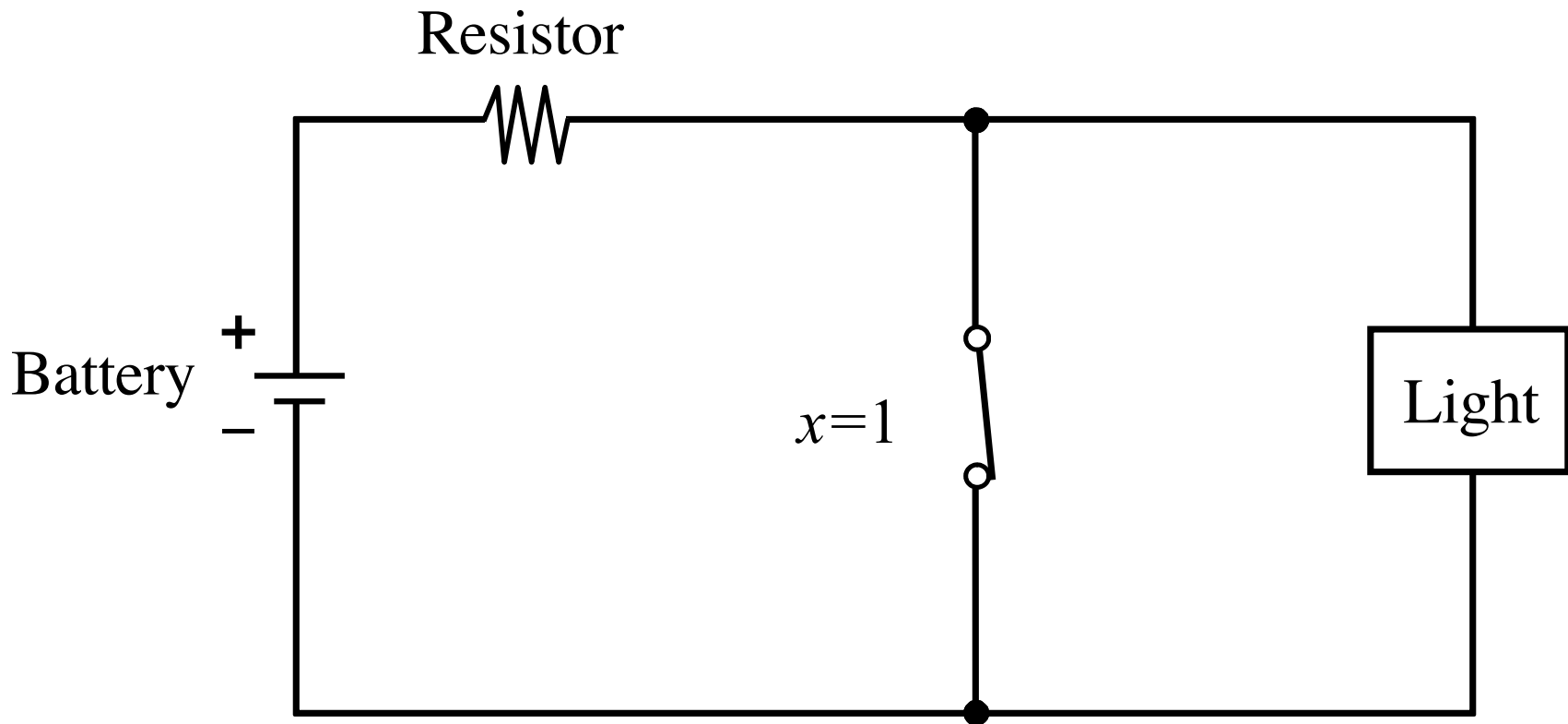

NOT Circuit

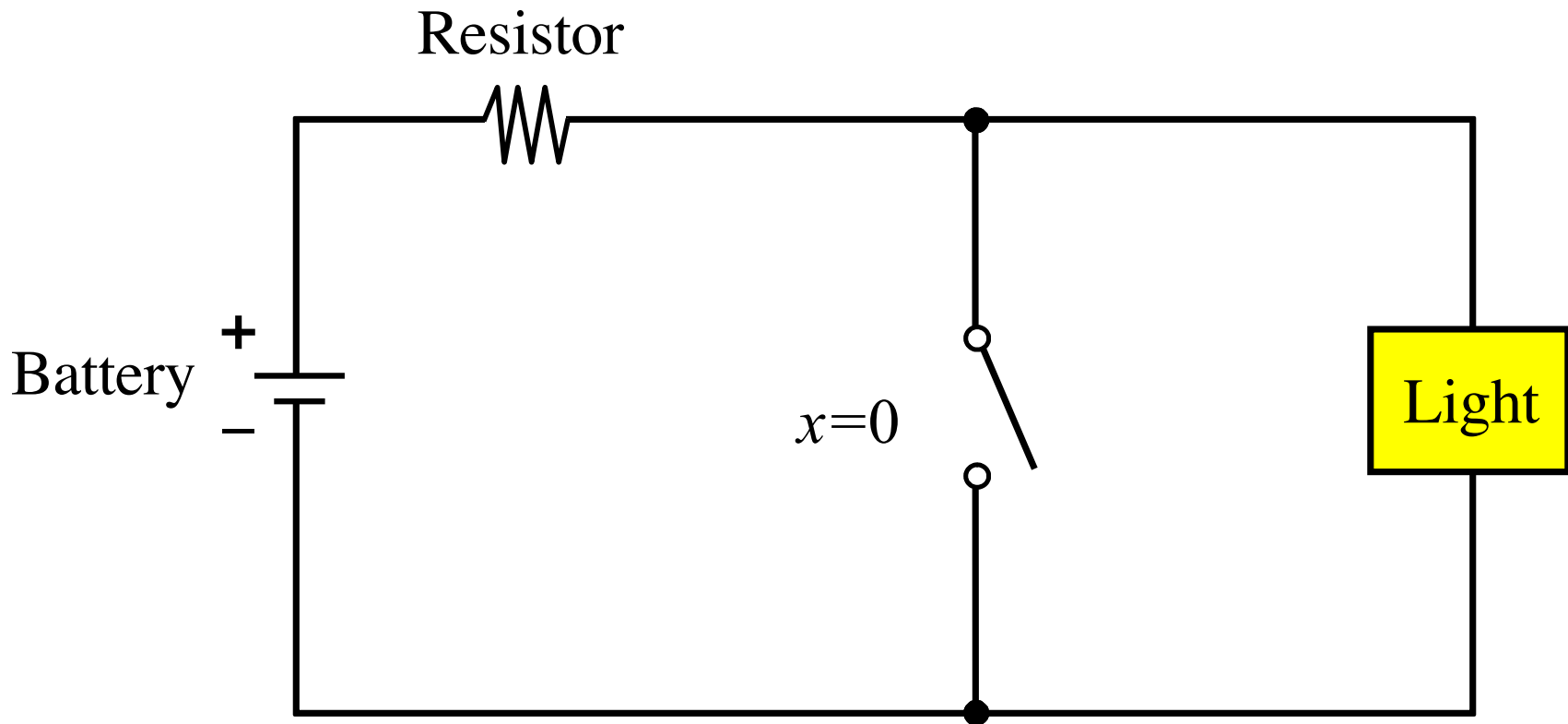

NAND with Switches

NAND Circuit

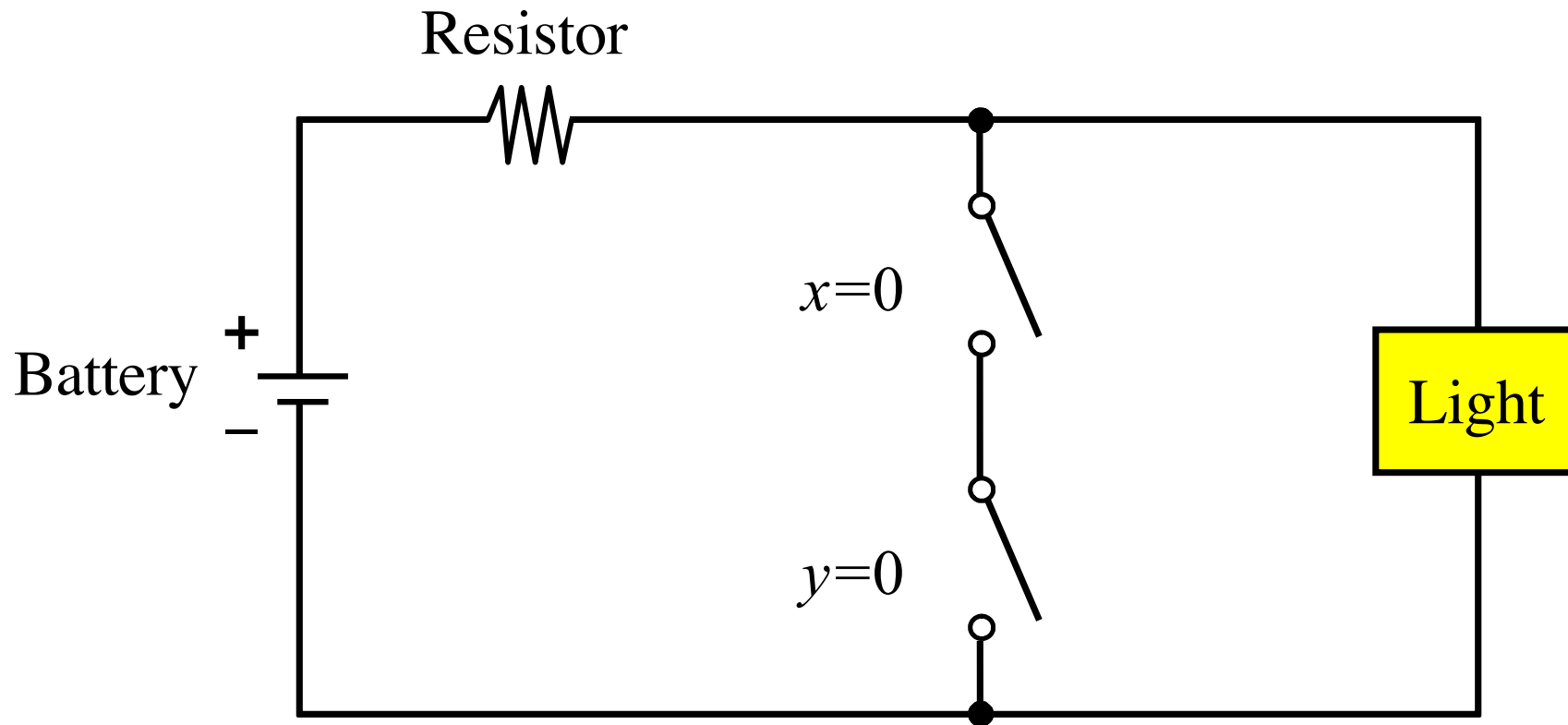

NAND Circuit

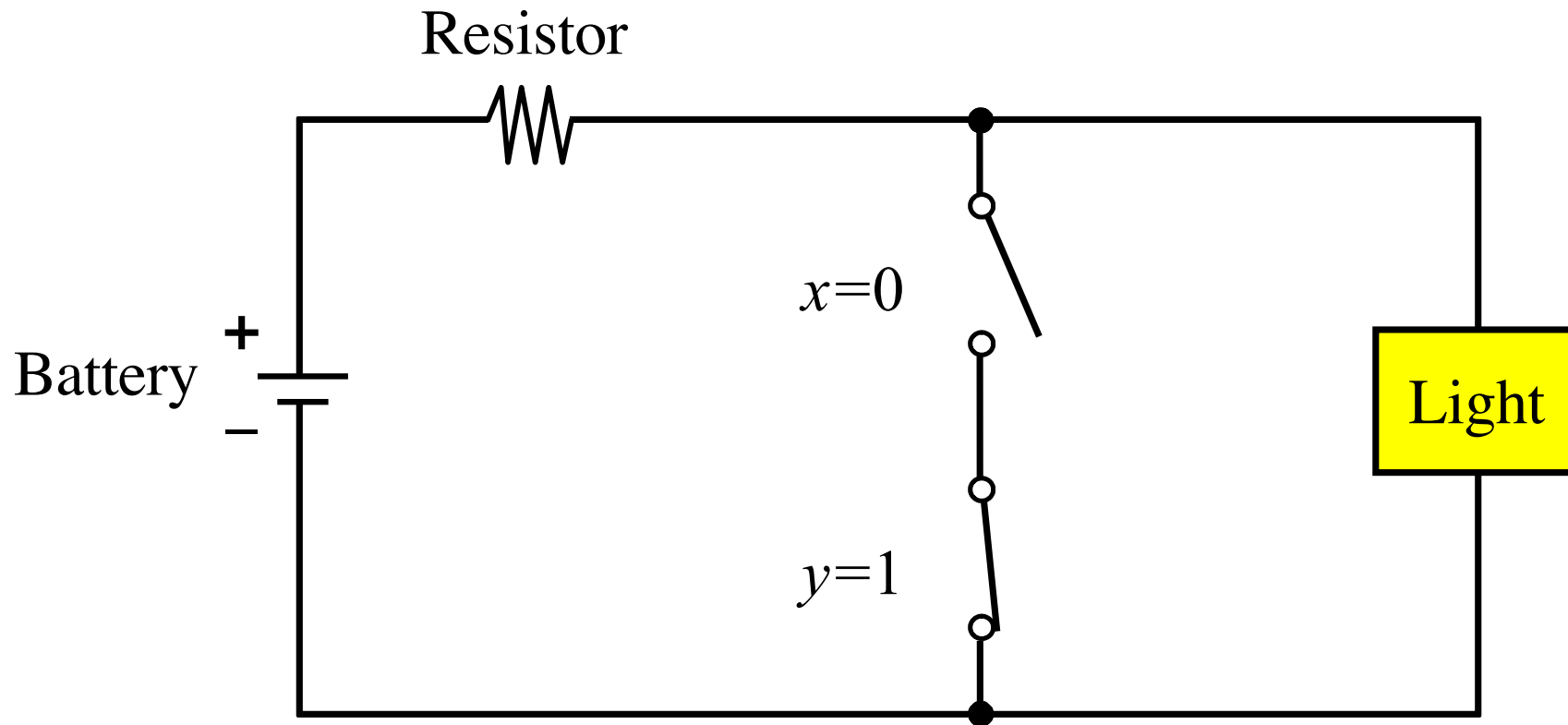

NAND Circuit

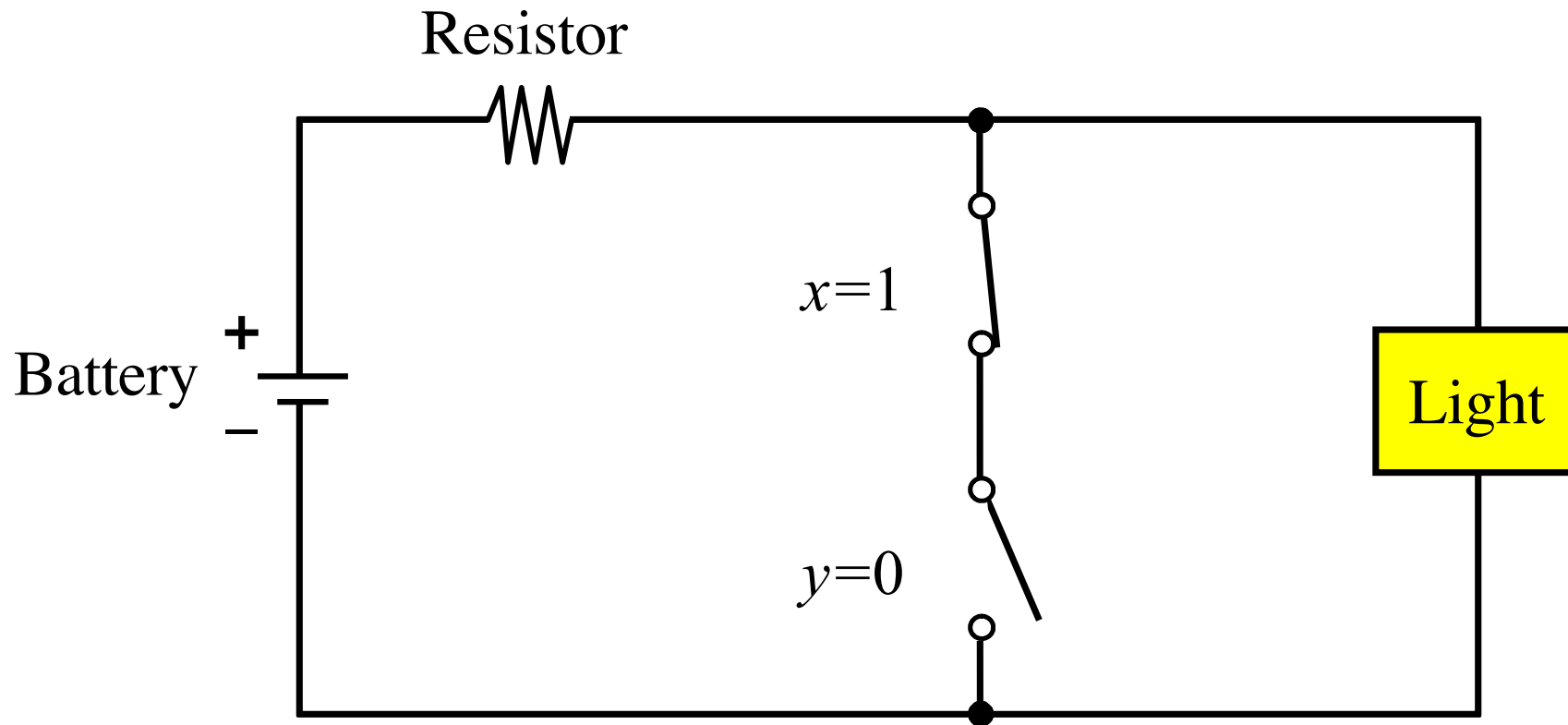

NAND Circuit

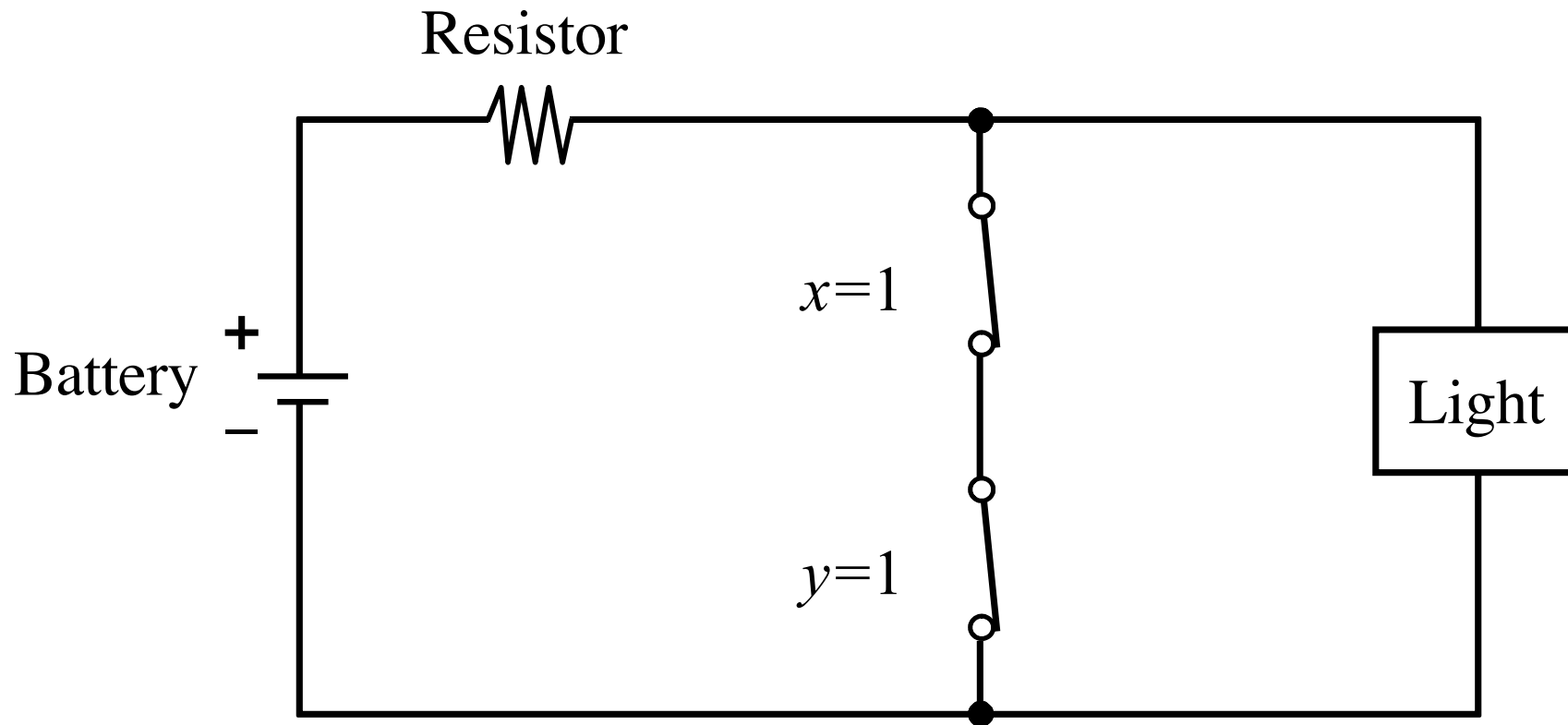

NOR with Switches

NOR Circuit

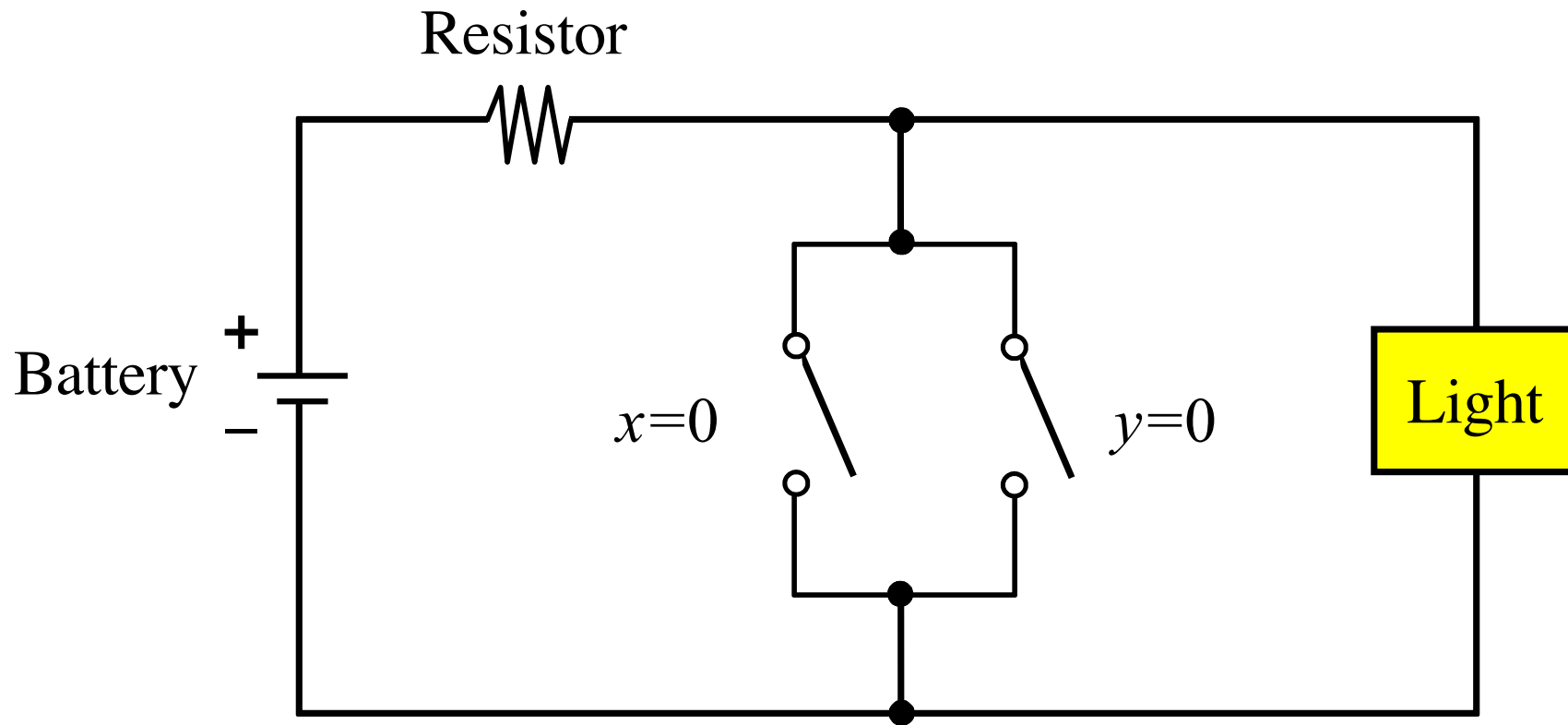

NOR Circuit

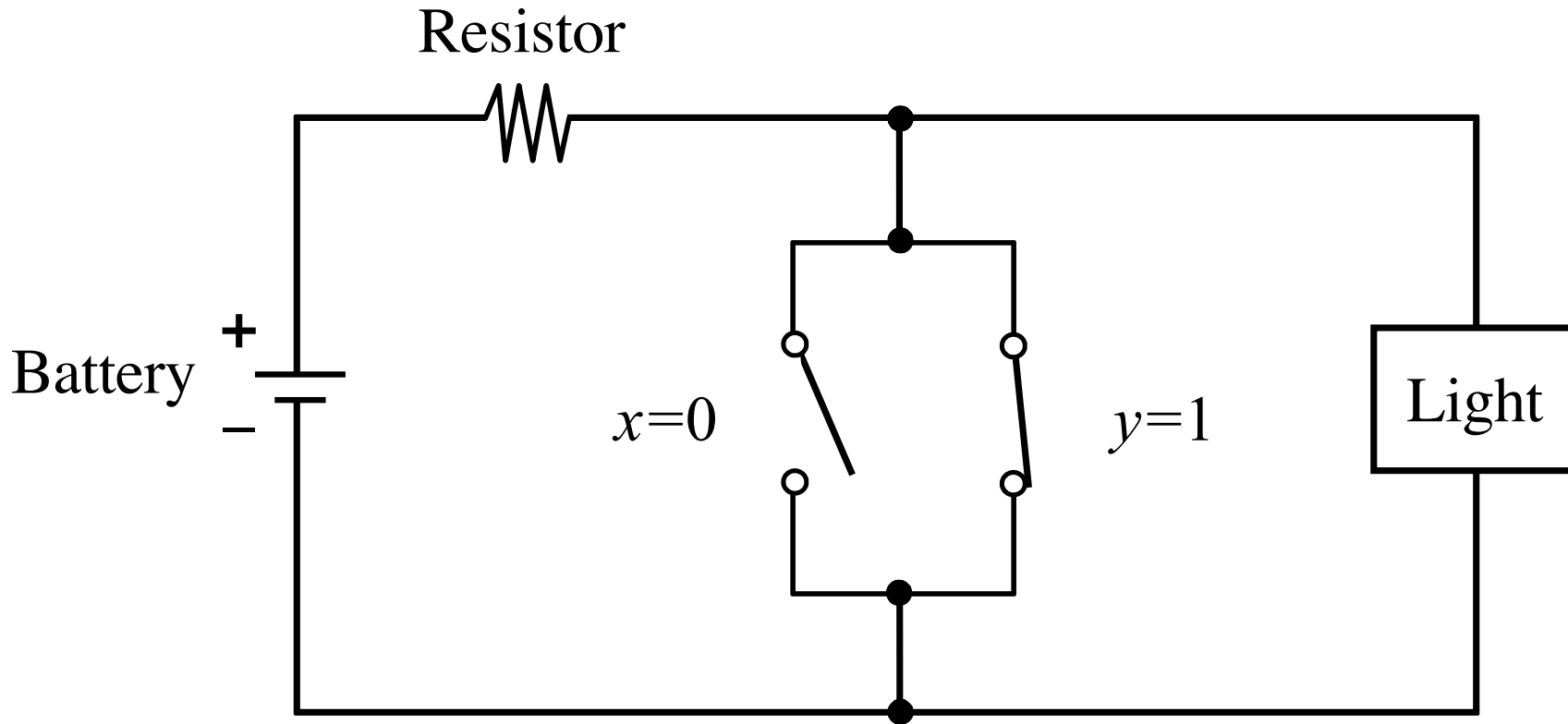

NOR Circuit

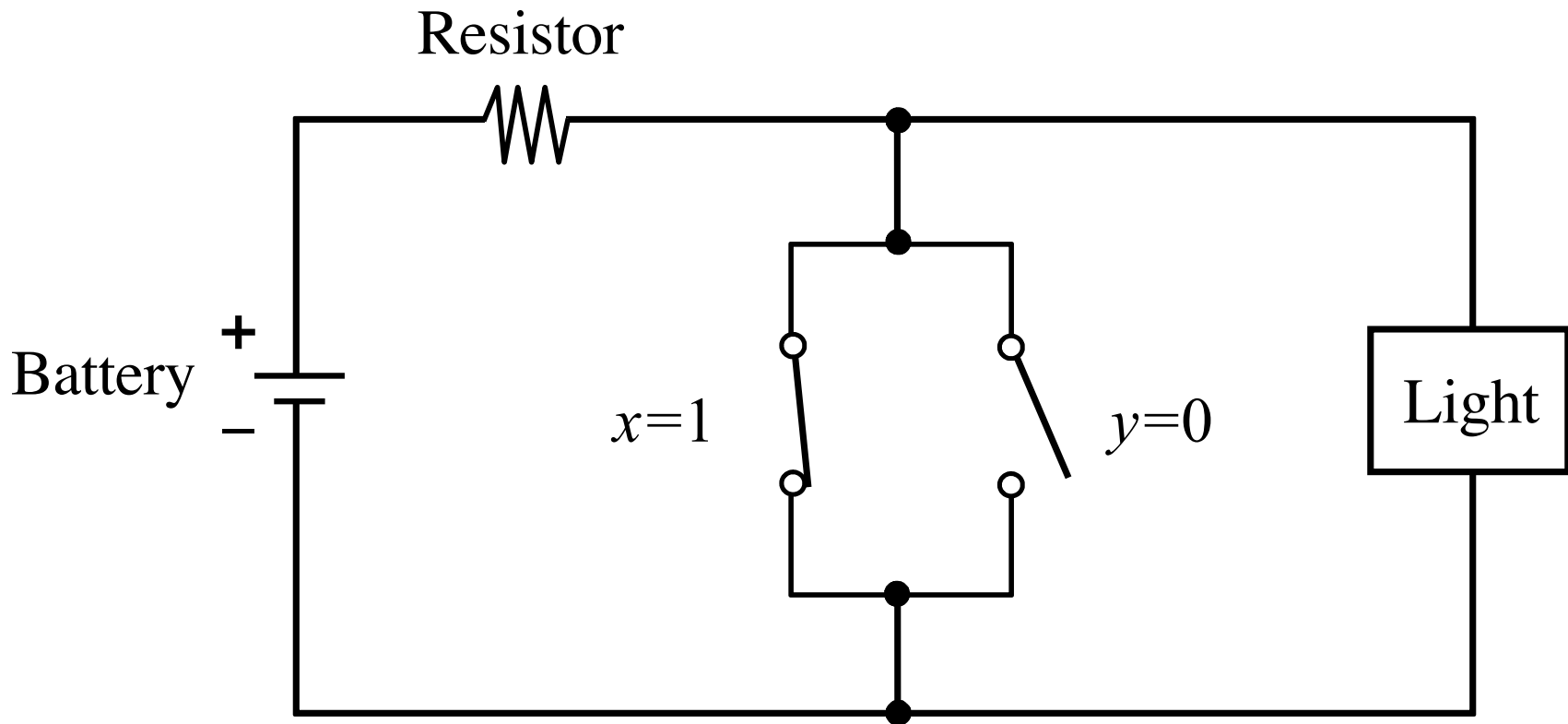

NOR Circuit

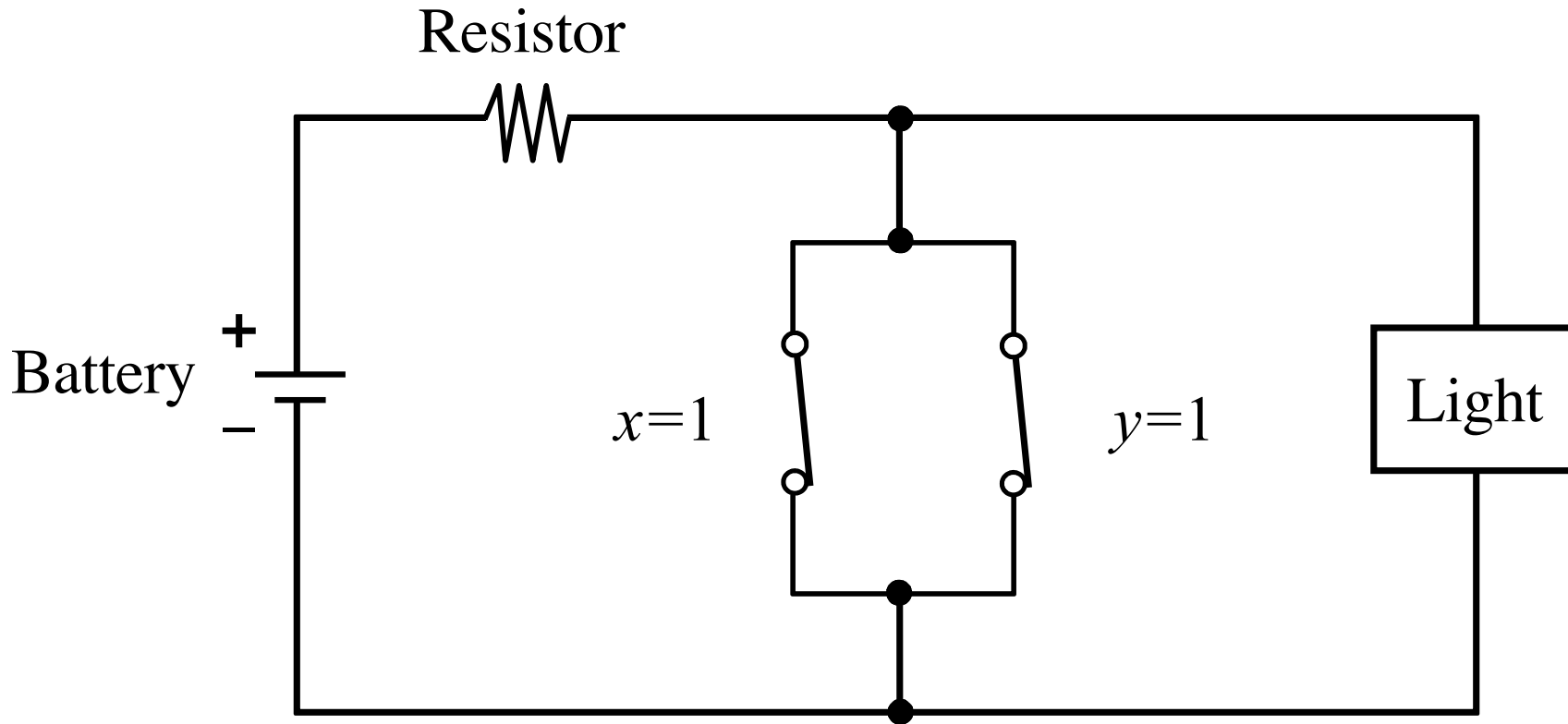

The Three Basic Logic Gates

x	NOT
0	1
1	0

x	y	AND
0	0	0
0	1	0
1	0	0
1	1	1

x	y	OR
0	0	0
0	1	1
1	0	1
1	1	1

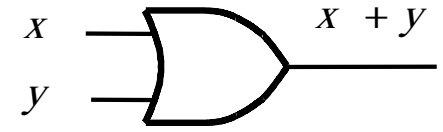
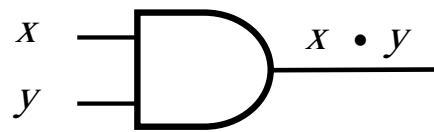
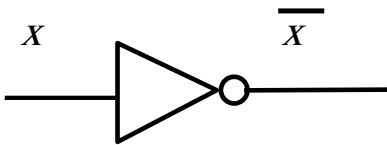

NAND and NOR

x	y	NAND
0	0	1
0	1	1
1	0	1
1	1	0

x	y	NOR
0	0	1
0	1	0
1	0	0
1	1	0

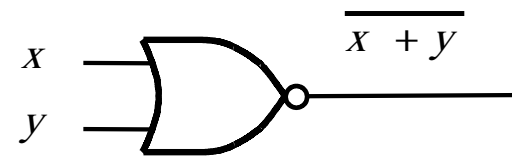
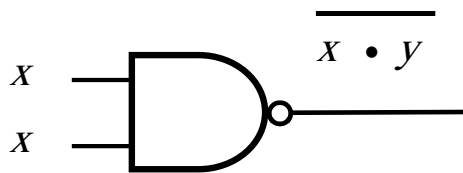

XOR and XNOR

x	y	XOR
0	0	0
0	1	1
1	0	1
1	1	0

x	y	XNOR
0	0	1
0	1	0
1	0	0
1	1	1

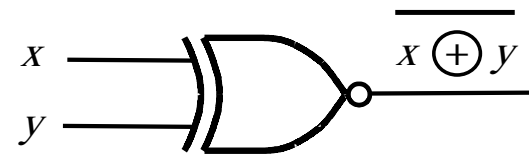
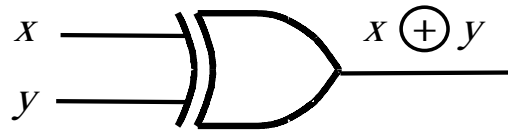

XNOR with Switches

XNOR Circuit

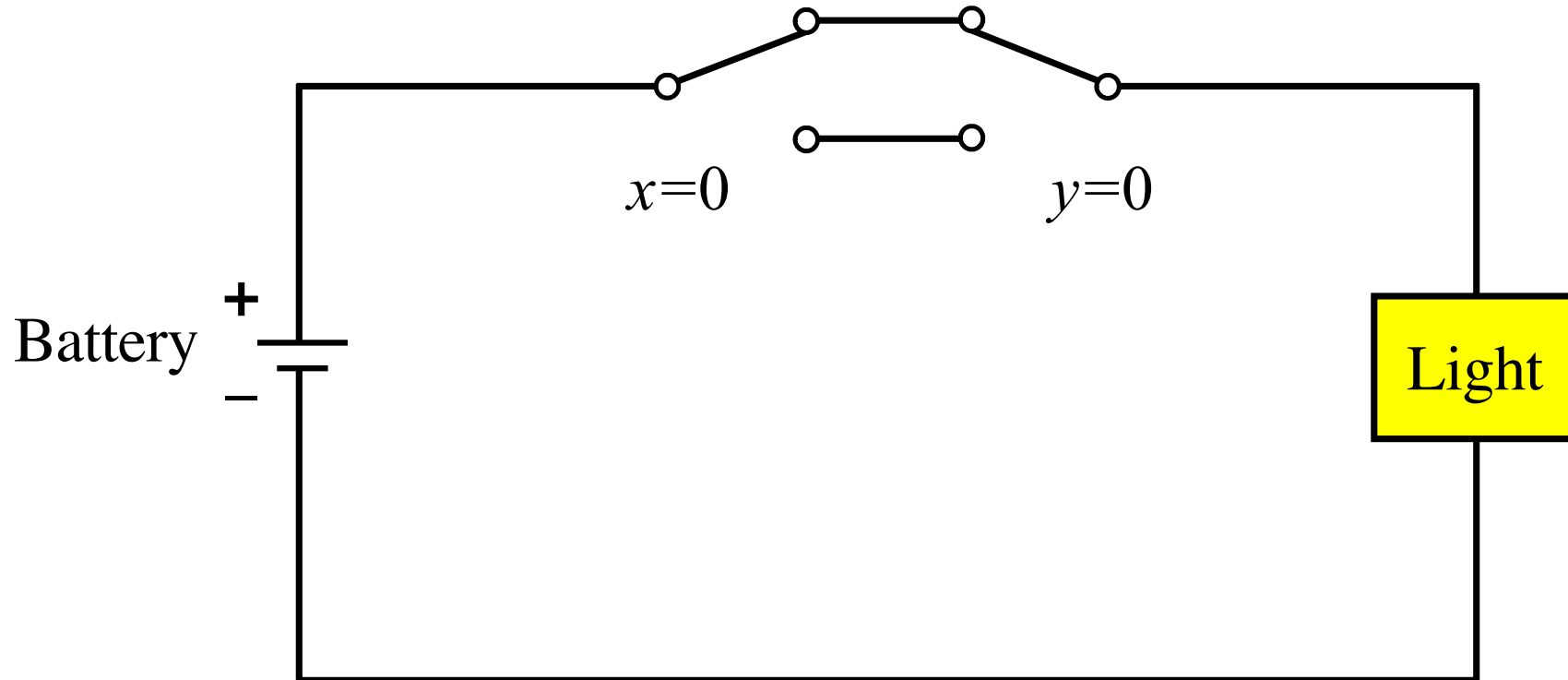

XNOR Circuit

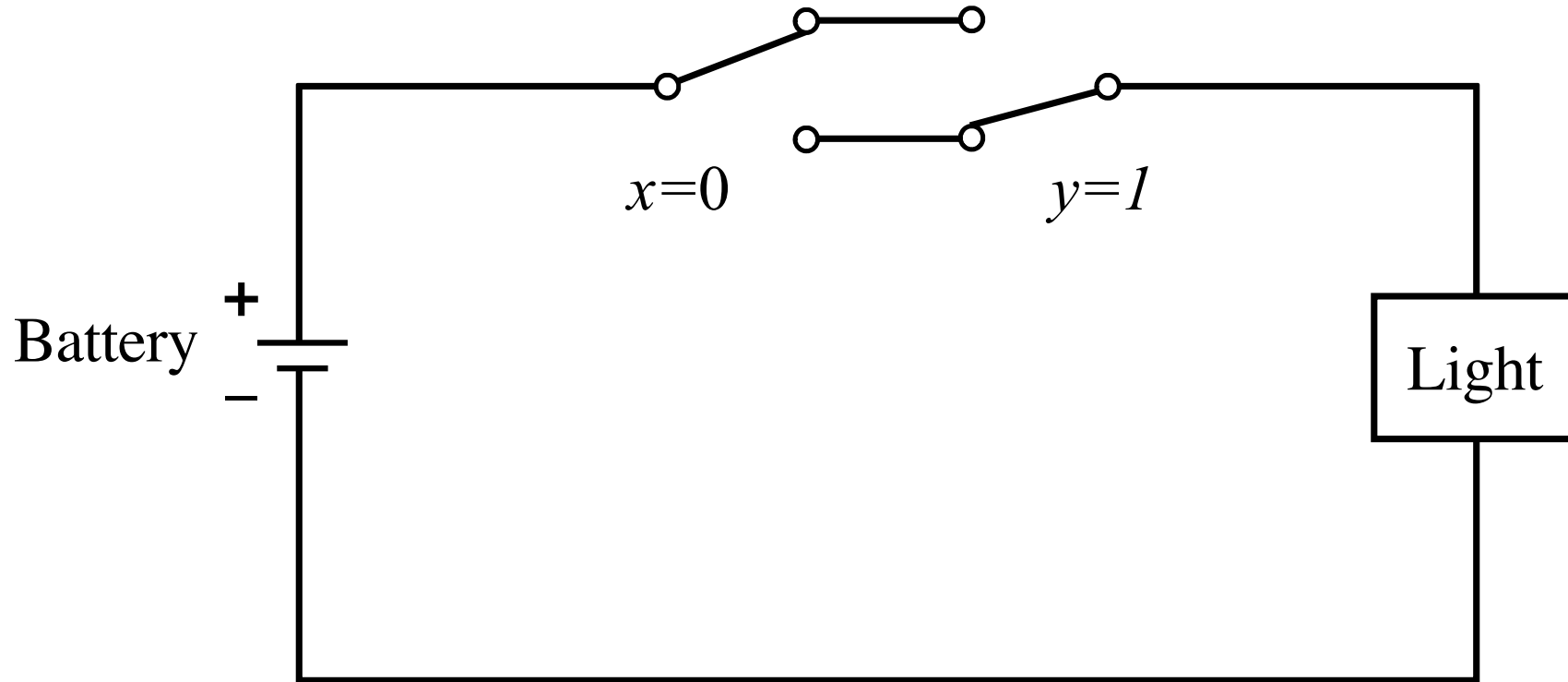

XNOR Circuit

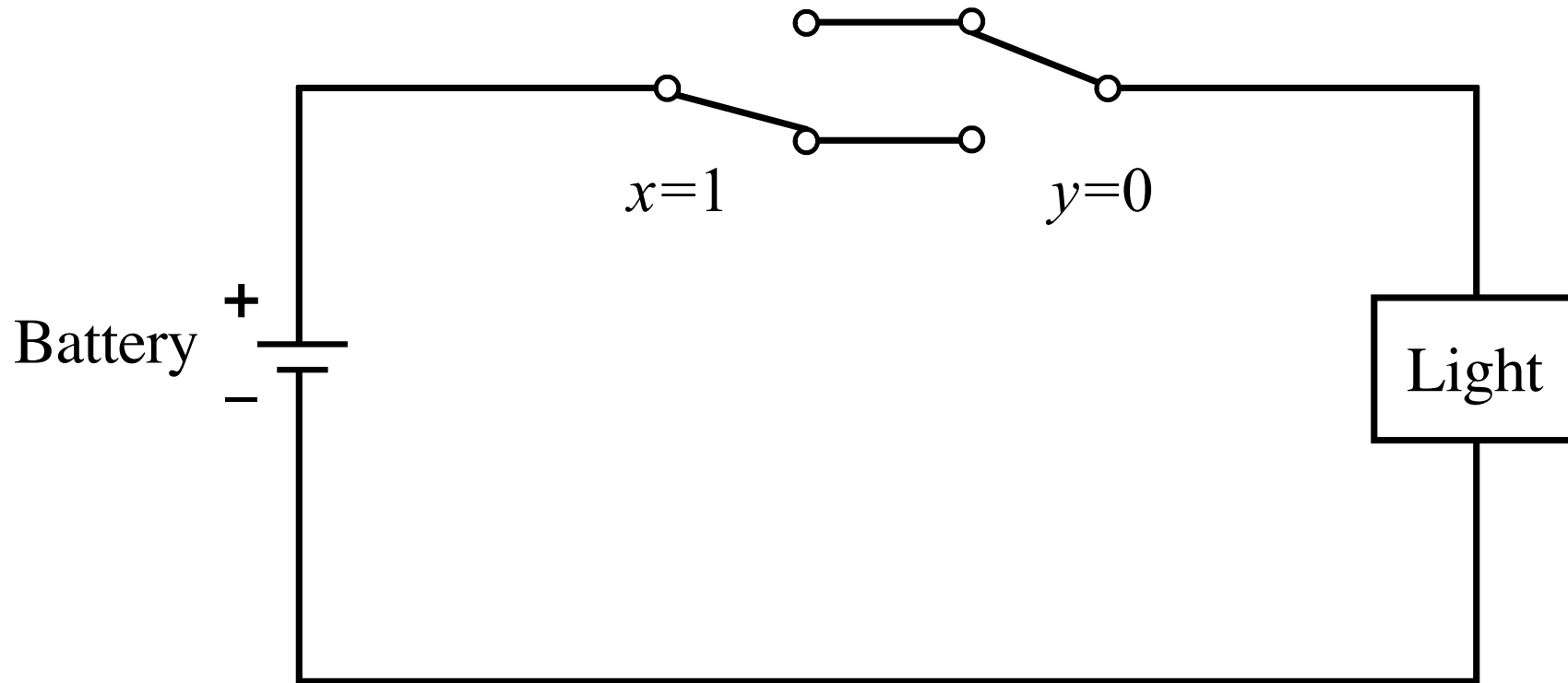

XNOR Circuit

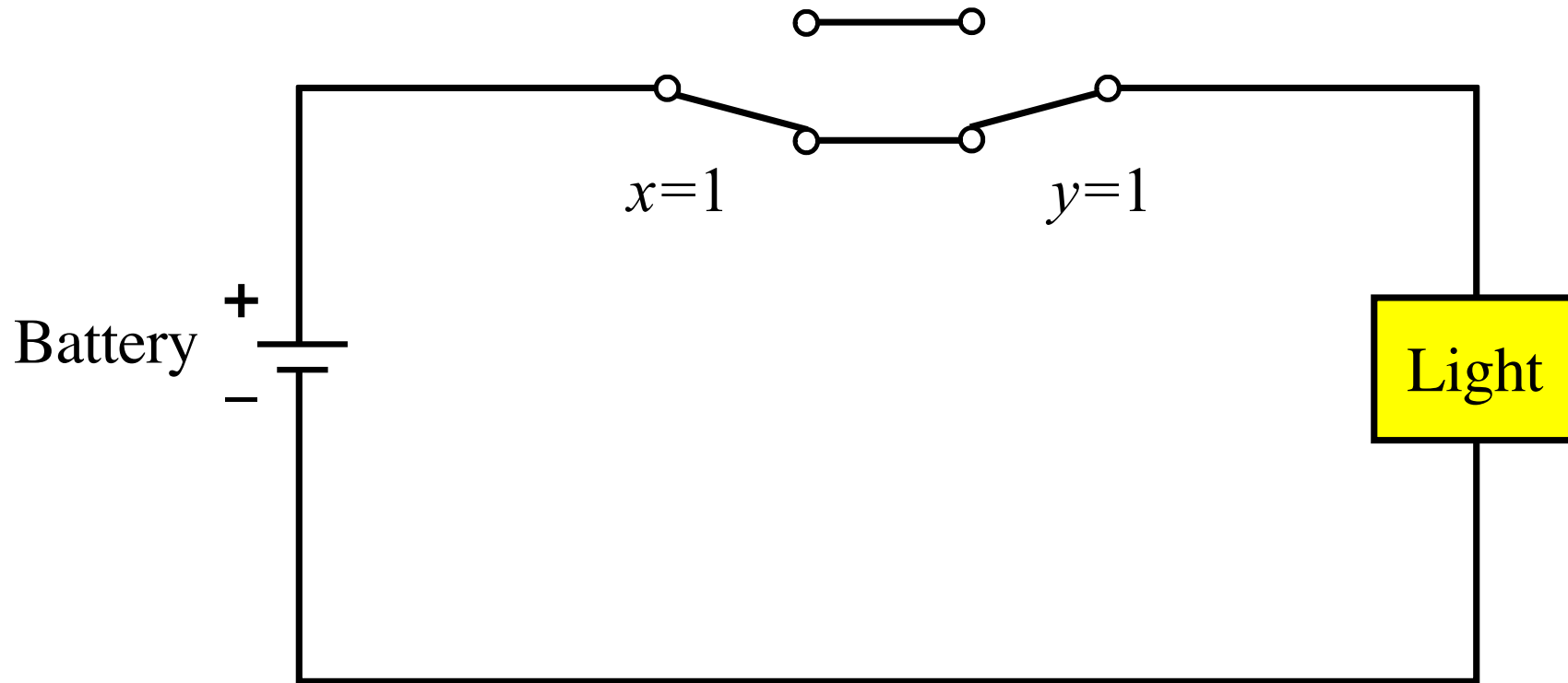

XOR with Switches

XOR Circuit

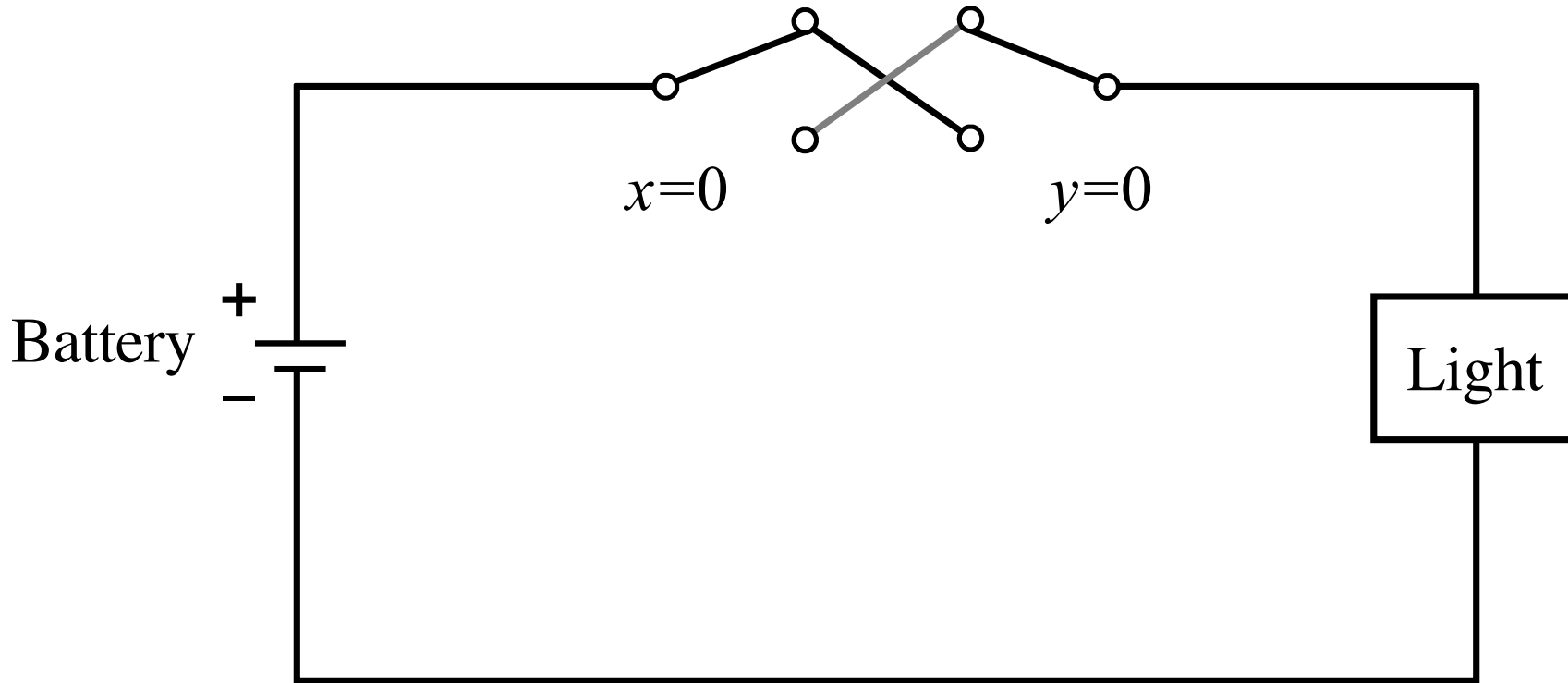

XOR Circuit

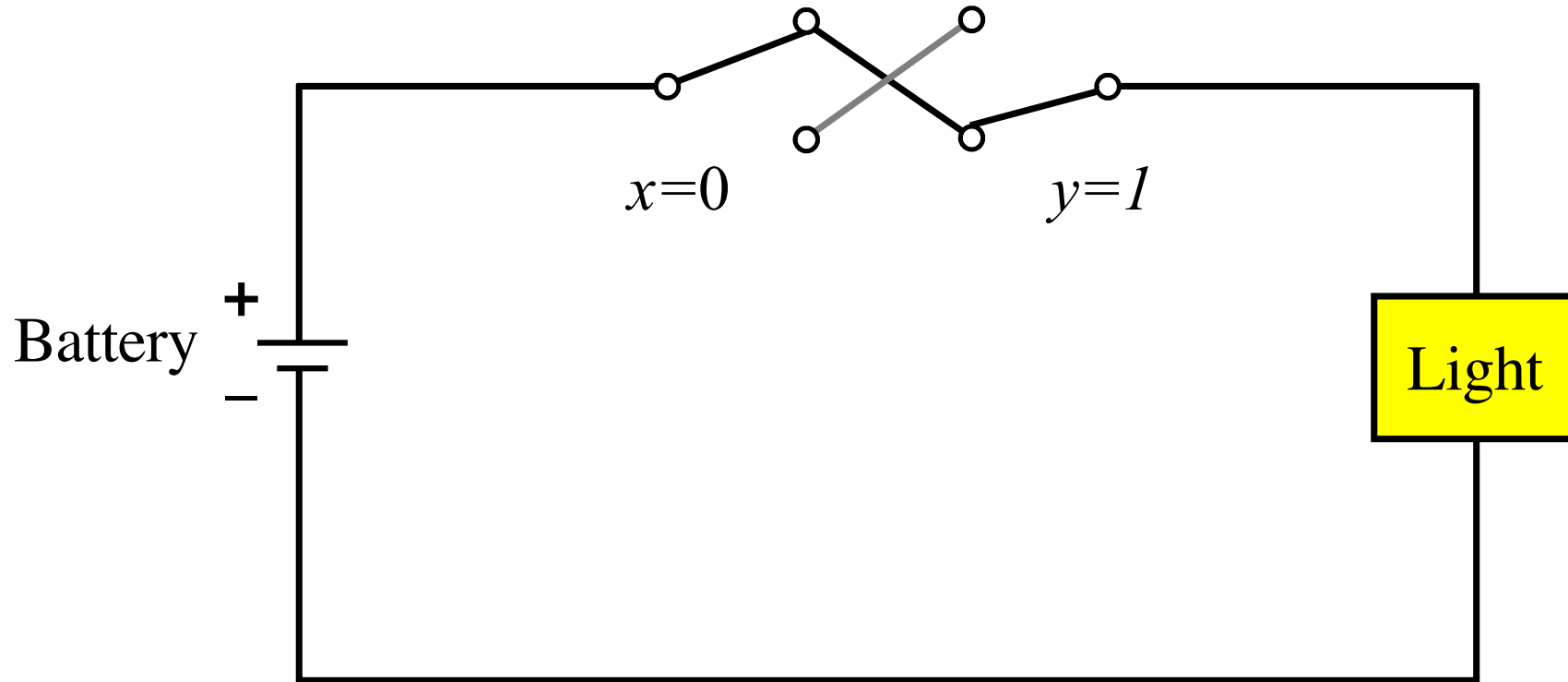

XOR Circuit

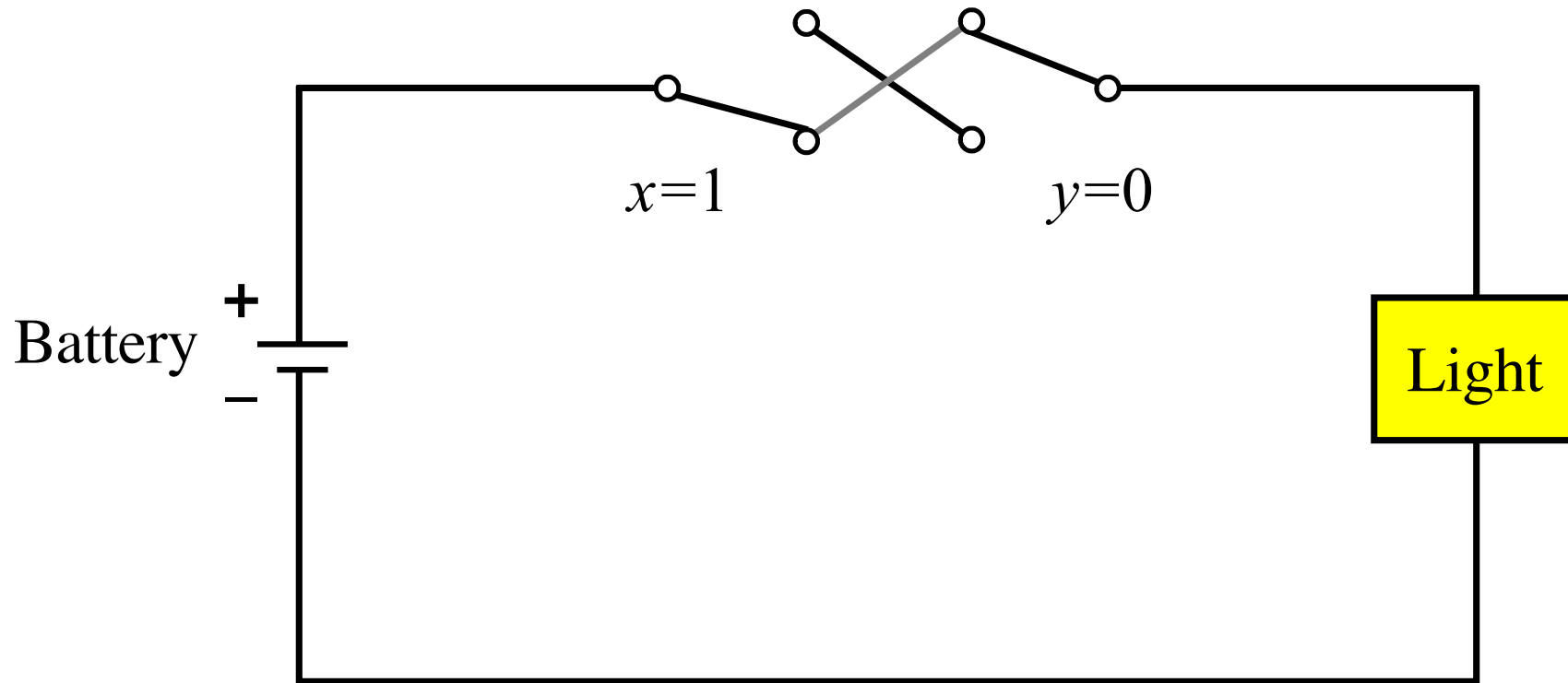

XOR Circuit

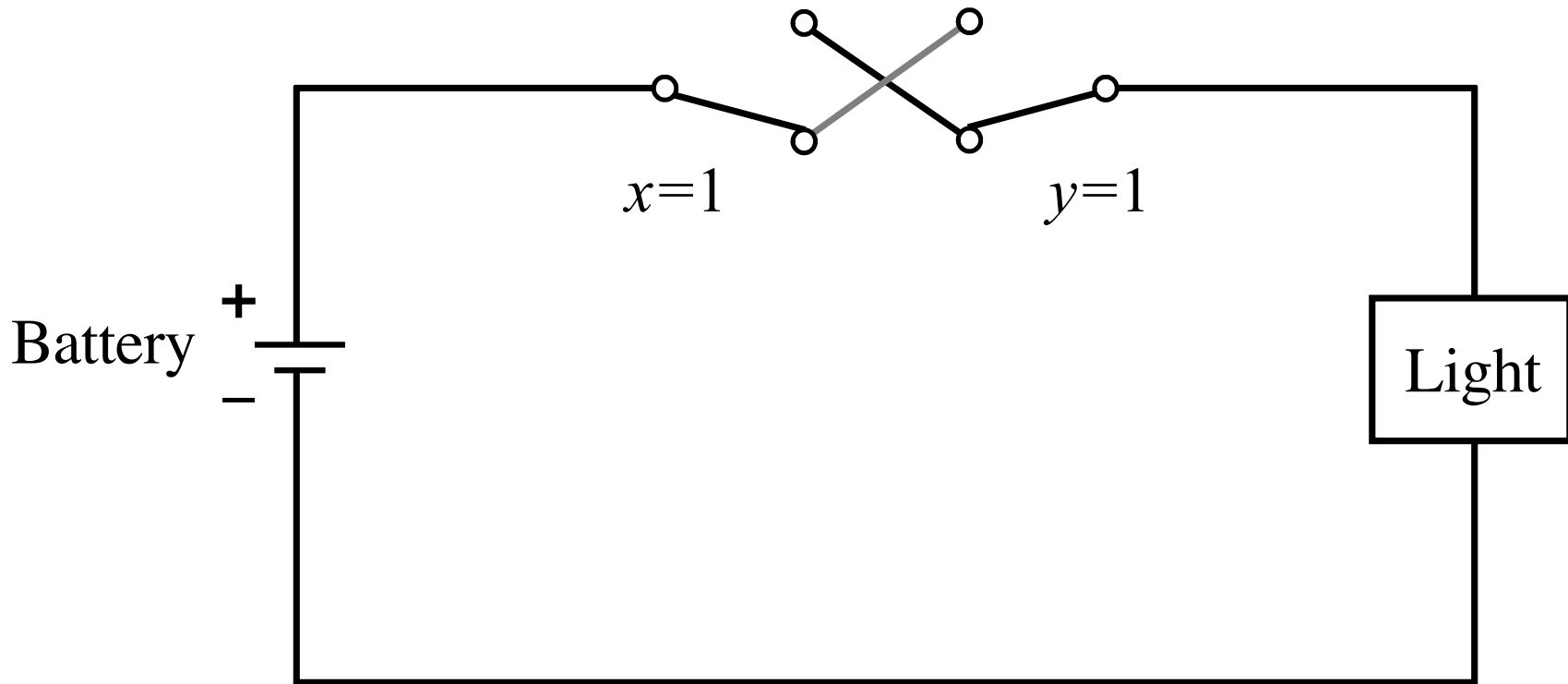

7-Segment Display Example

7-Segment Display

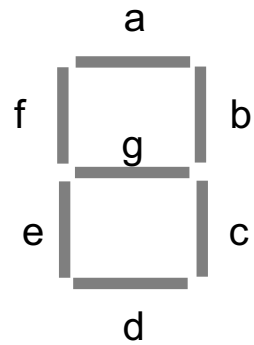

Displaying Some Numbers

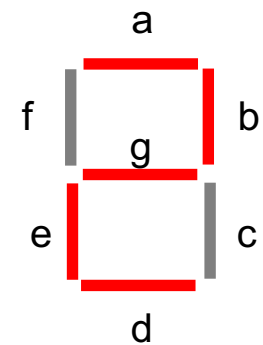
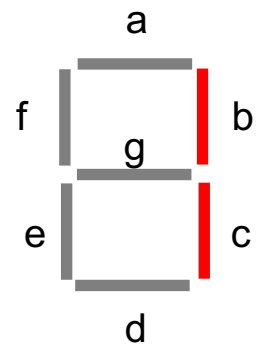
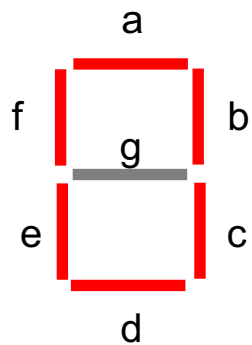

Displaying Some Hexadecimal Numbers

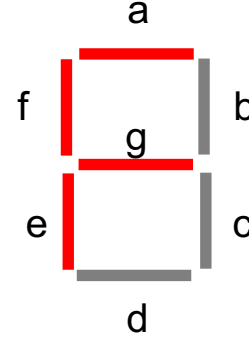
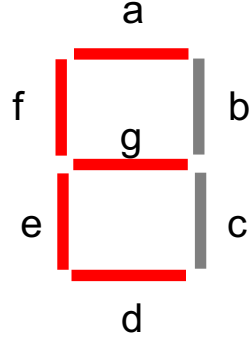
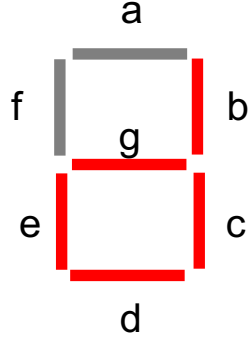
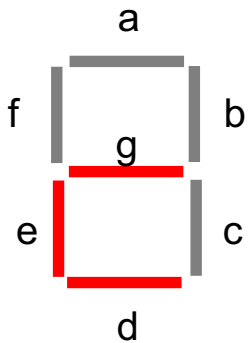
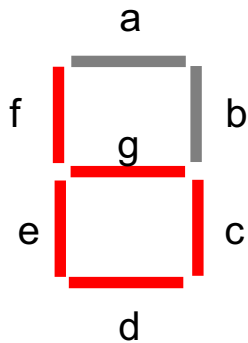
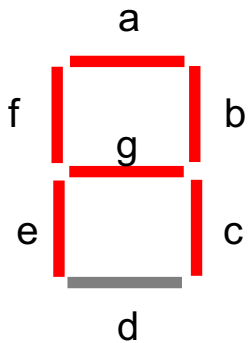

Display of numbers

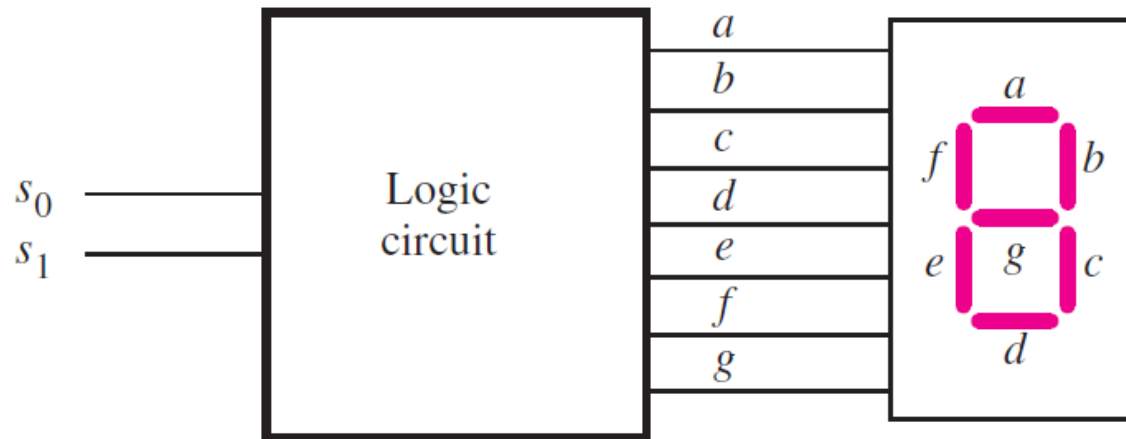

(a) Logic circuit and 7-segment display

	s_1	s_0	a	b	c	d	e	f	g
0	0	0	1	1	1	1	1	1	0
1	0	1	0	1	1	0	0	0	0
2	1	0	1	1	0	1	1	0	1

(b) Truth table

Display of numbers

	s_1	s_0	a	b	c	d	e	f	g
0	0	0	1	1	1	1	1	1	0
1	0	1	0	1	1	0	0	0	0
2	1	0	1	1	0	1	1	0	1

Display of numbers

	s_1	s_0	a	b	c	d	e	f	g
0	0	0	1	1	1	1	1	1	0
1	0	1	0	1	1	0	0	0	0
2	1	0	1	1	0	1	1	0	1

$$a = \overline{s_0}$$

$$c = \overline{s_1}$$

$$e = \overline{s_0}$$

$$g = s_1 \overline{s_0}$$

$$b = 1$$

$$d = \overline{s_0}$$

$$f = \overline{s_1} \overline{s_0}$$

Intro to Verilog

History

- **Created in 1983/1984**
- **Verilog-95 (IEEE standard 1364-1995)**
- **Verilog 2001 (IEEE Standard 1364-2001)**
- **Verilog 2005 (IEEE Standard 1364-2005)**
- **SystemVerilog**
- **SystemVerilog 2009 (IEEE Standard 1800-2009).**

HDL

- **Hardware Description Language**
- **Verilog HDL**
- **VHDL**

Verilog HDL \neq VHDL

- **These are two different Languages!**
- **Verilog is closer to C**
- **VHDL is closer to Ada**

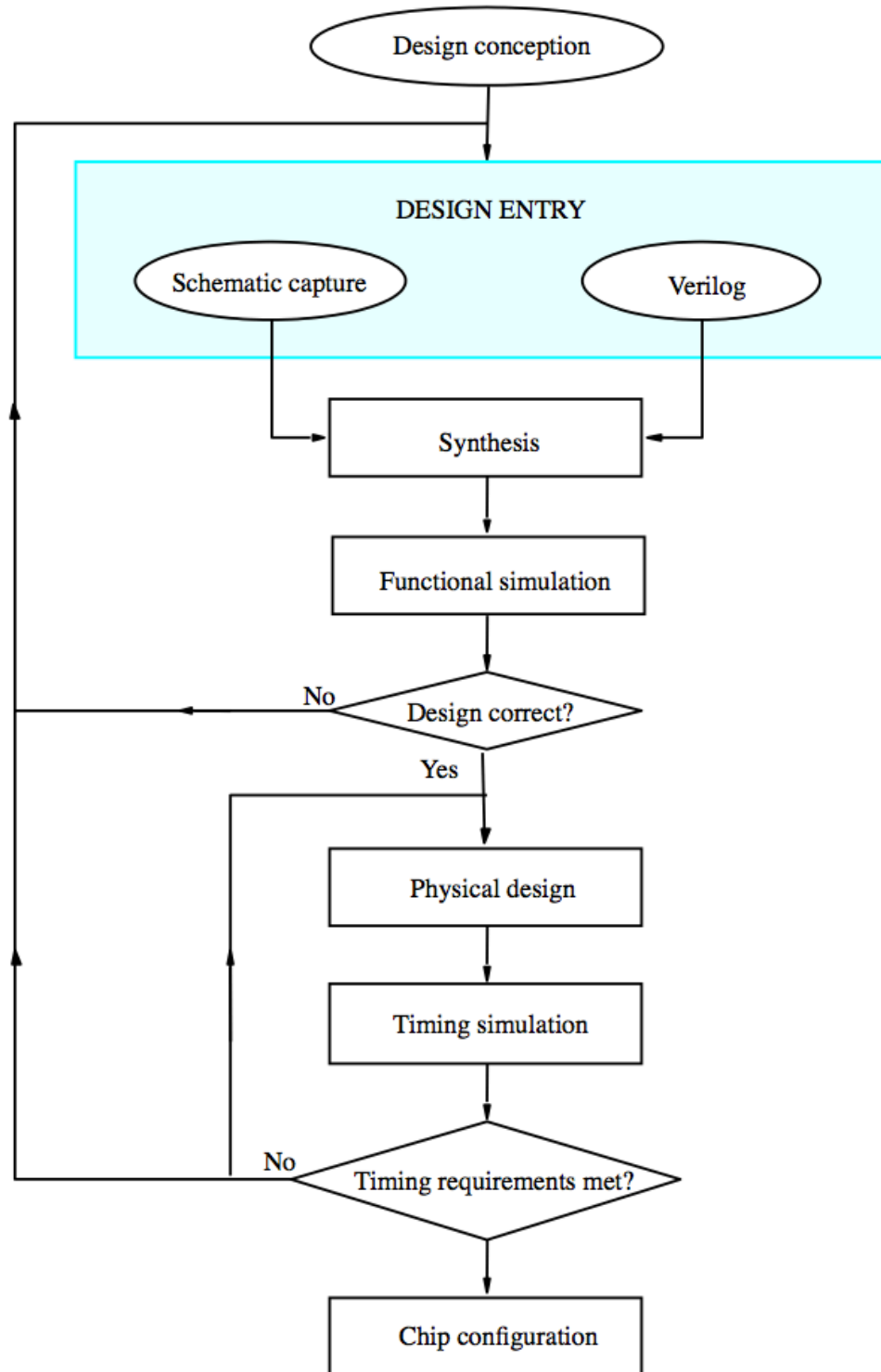

[Figure 2.35 from the textbook]

Sample Verilog Program

```
module example1 (x1, x2, s, f);  
    input x1, x2, s;  
    output f;  
  
    not (k, s);  
    and (g, k, x1);  
    and (h, s, x2);  
    or (f, g, h);  
  
endmodule
```

The Three Basic Logic Gates

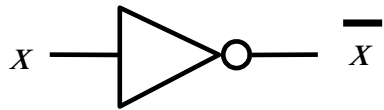

NOT gate

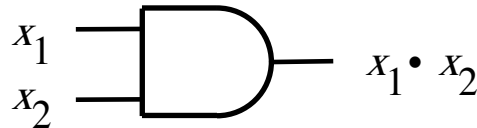

AND gate

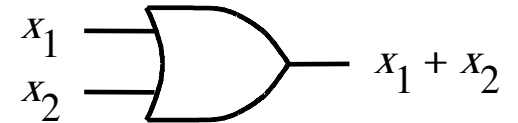

OR gate

You can build any circuit using only these three gates

How to specify a NOT gate in Verilog

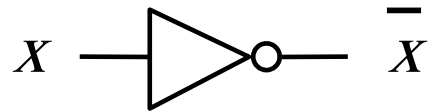

NOT gate

How to specify a NOT gate in Verilog

we'll use the letter *y* for the output

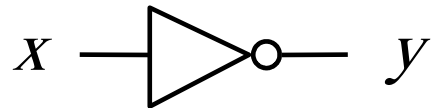

NOT gate

How to specify a NOT gate in Verilog

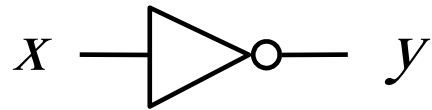

`not (y, x)`

NOT gate

Verilog code

How to specify an AND gate in Verilog

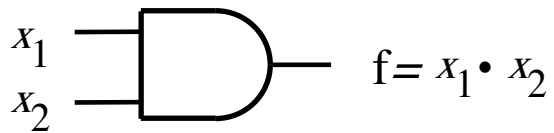

AND gate

`and (f, x1, x2)`

Verilog code

How to specify an OR gate in Verilog

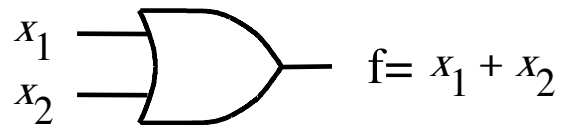

`or (f, x1, x2)`

OR gate

Verilog code

Verilog Code

Structural

Behavioral

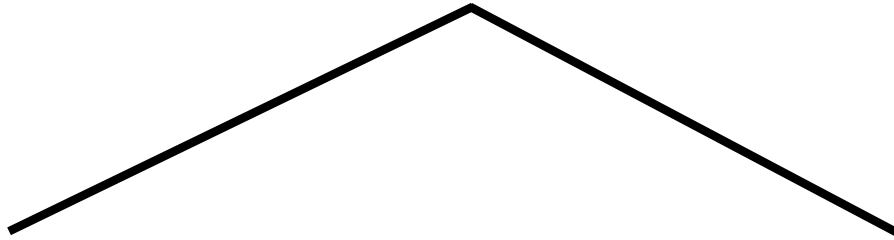

Structural Verilog

2-to-1 Multiplexer in Verilog (structural syntax)

2-1 Multiplexer

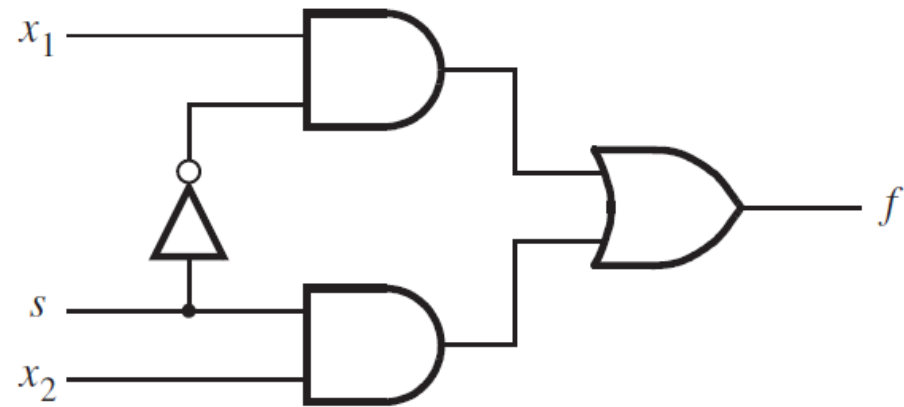

Verilog Code for a 2-1 Multiplexer

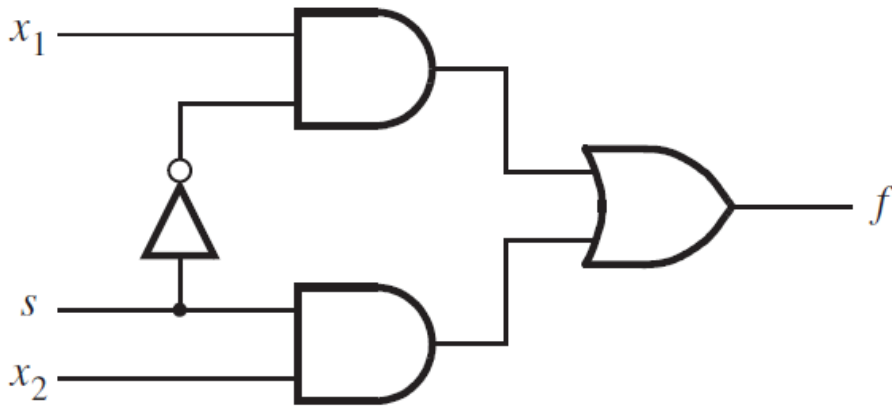

```
module example1 (x1, x2, s, f);  
  input x1, x2, s;  
  output f;  
  
  not (k, s);  
  and (g, k, x1);  
  and (h, s, x2);  
  or (f, g, h);  
  
endmodule
```

Verilog Code for a 2-1 Multiplexer

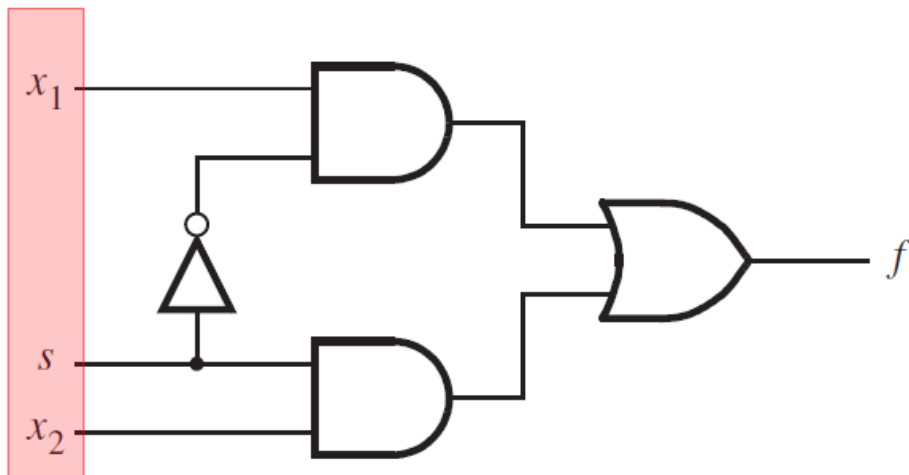

```
module example1 (x1, x2, s, f);  
  input x1, x2, s;  
  output f;  
  
  not (k, s);  
  and (g, k, x1);  
  and (h, s, x2);  
  or (f, g, h);  
  
endmodule
```

Verilog Code for a 2-1 Multiplexer

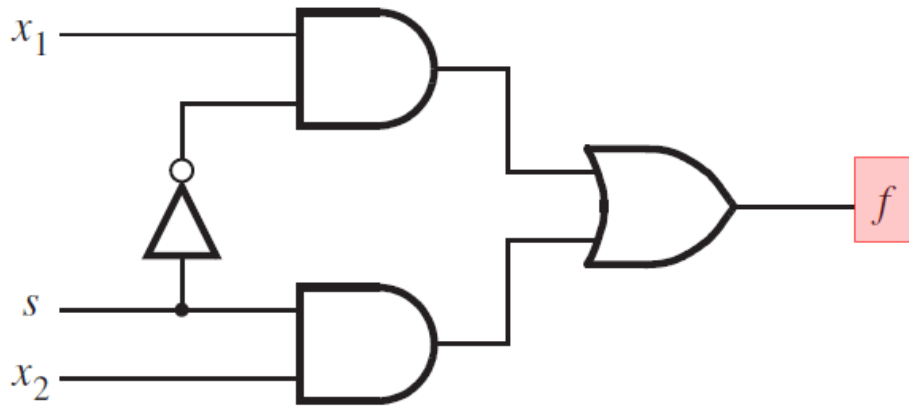

```
module example1 (x1, x2, s, f);  
  input x1, x2, s;  
  output f;  
  
  not (k, s);  
  and (g, k, x1);  
  and (h, s, x2);  
  or (f, g, h);  
  
endmodule
```

Verilog Code for a 2-1 Multiplexer

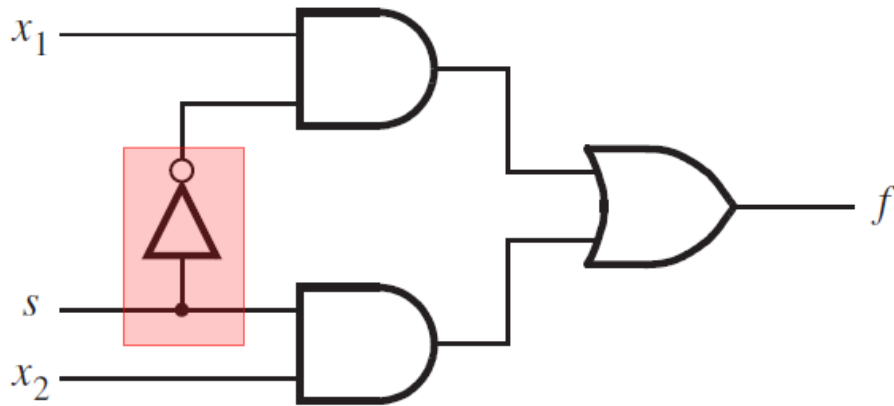

```
module example1 (x1, x2, s, f);  
  input x1, x2, s;  
  output f;  
  
  not (k, s);  
  and (g, k, x1);  
  and (h, s, x2);  
  or (f, g, h);  
  
endmodule
```

Verilog Code for a 2-1 Multiplexer

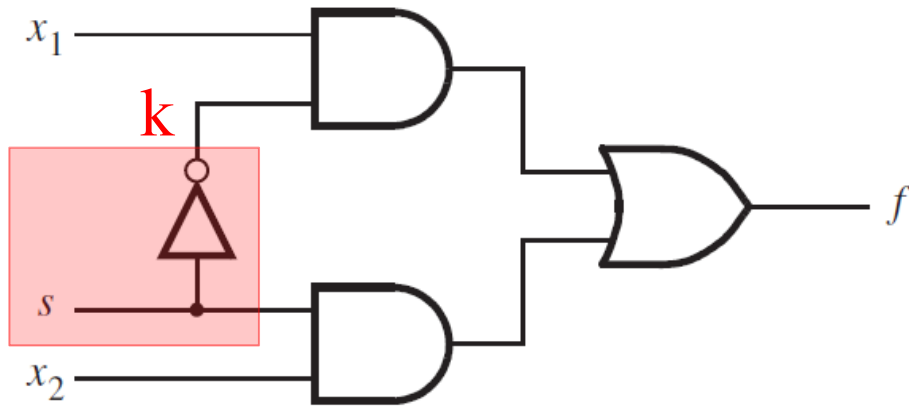

```
module example1 (x1, x2, s, f);  
  input x1, x2, s;  
  output f;  
  
  not (k, s);  
  and (g, k, x1);  
  and (h, s, x2);  
  or (f, g, h);  
  
endmodule
```

Verilog Code for a 2-1 Multiplexer

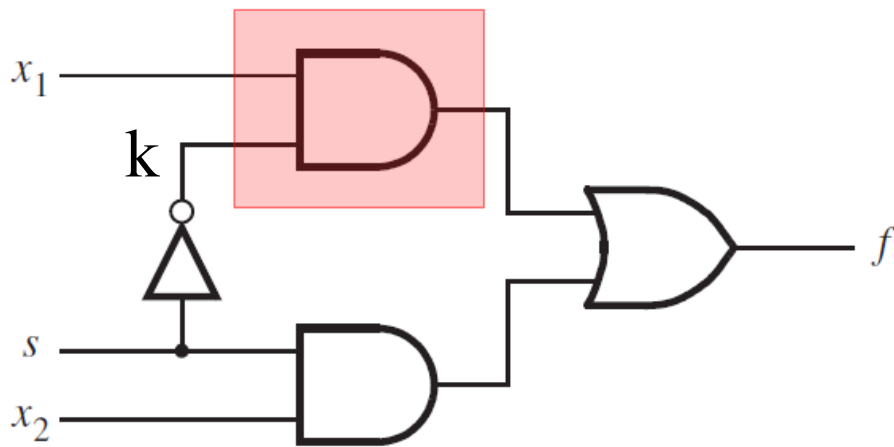

```
module example1 (x1, x2, s, f);  
  input x1, x2, s;  
  output f;  
  
  not (k, s);  
  and (g, k, x1);  
  and (h, s, x2);  
  or (f, g, h);  
  
endmodule
```

Verilog Code for a 2-1 Multiplexer

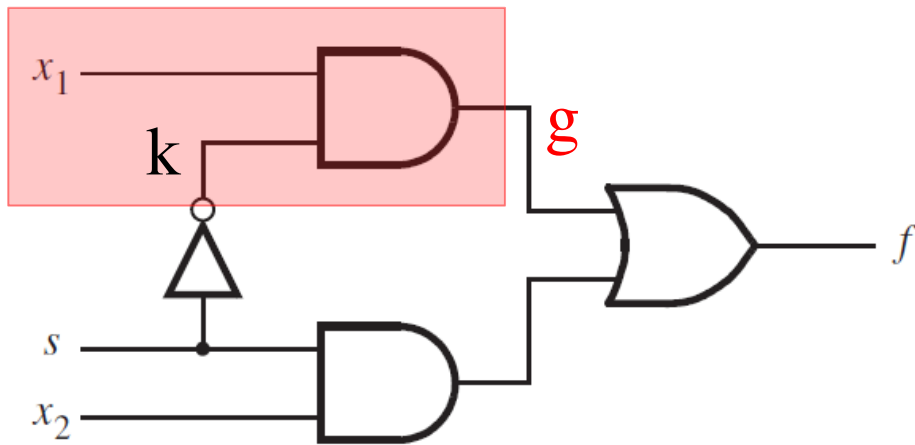

```
module example1 (x1, x2, s, f);  
    input x1, x2, s;  
    output f;  
  
    not (k, s);  
    and (g, k, x1);  
    and (h, s, x2);  
    or (f, g, h);  
  
endmodule
```

Verilog Code for a 2-1 Multiplexer

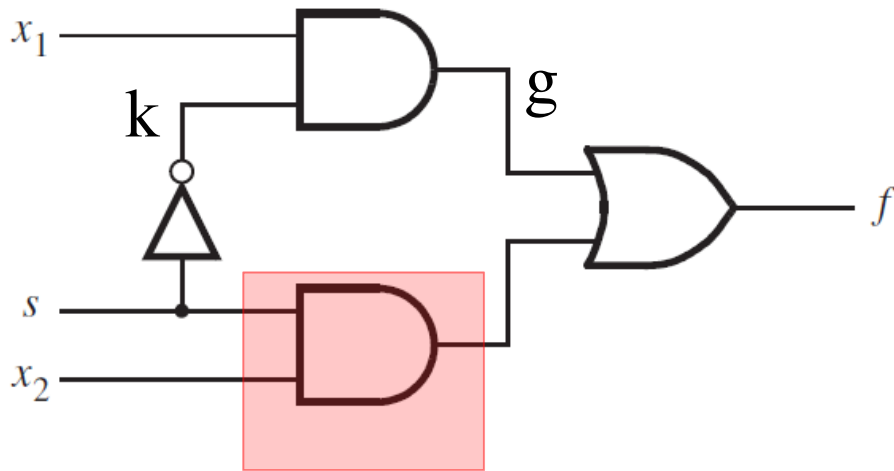

```
module example1 (x1, x2, s, f);  
  input x1, x2, s;  
  output f;  
  
  not (k, s);  
  and (g, k, x1);  
  and (h, s, x2);  
  or (f, g, h);  
  
endmodule
```

Verilog Code for a 2-1 Multiplexer

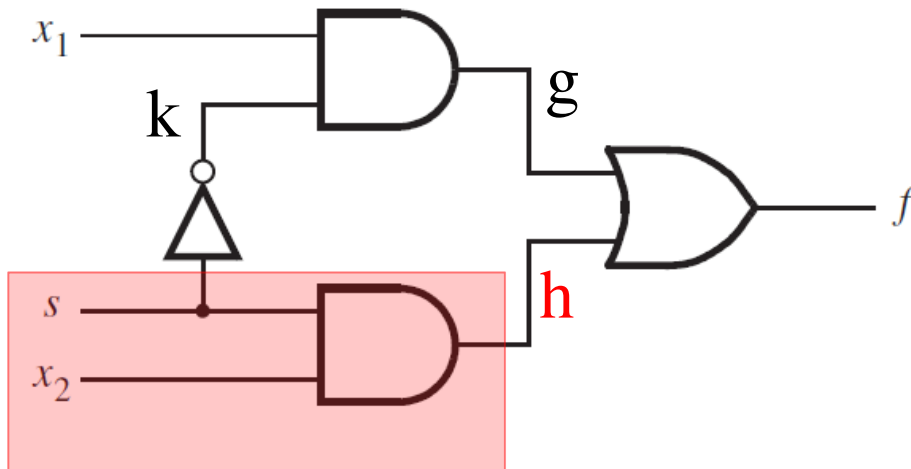

```
module example1 (x1, x2, s, f);  
  input x1, x2, s;  
  output f;  
  
  not (k, s);  
  and (g, k, x1);  
  and (h, s, x2);  
  or (f, g, h);  
  
endmodule
```

Verilog Code for a 2-1 Multiplexer

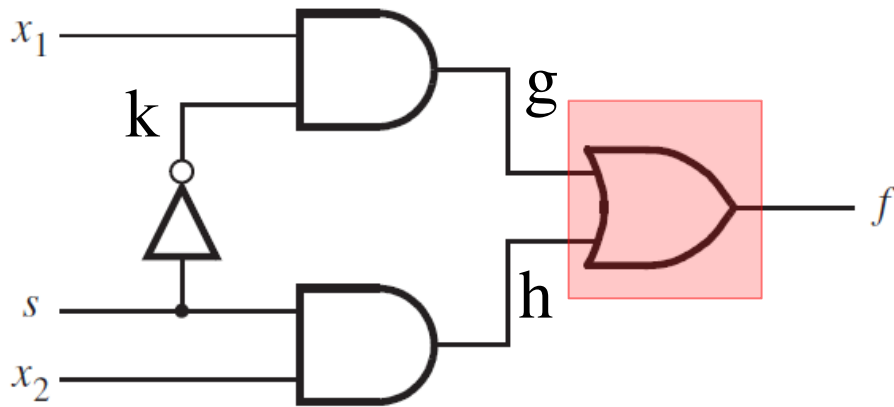

```
module example1 (x1, x2, s, f);  
  input x1, x2, s;  
  output f;  
  
  not (k, s);  
  and (g, k, x1);  
  and (h, s, x2);  
  or (f, g, h);  
  
endmodule
```

Verilog Code for a 2-1 Multiplexer

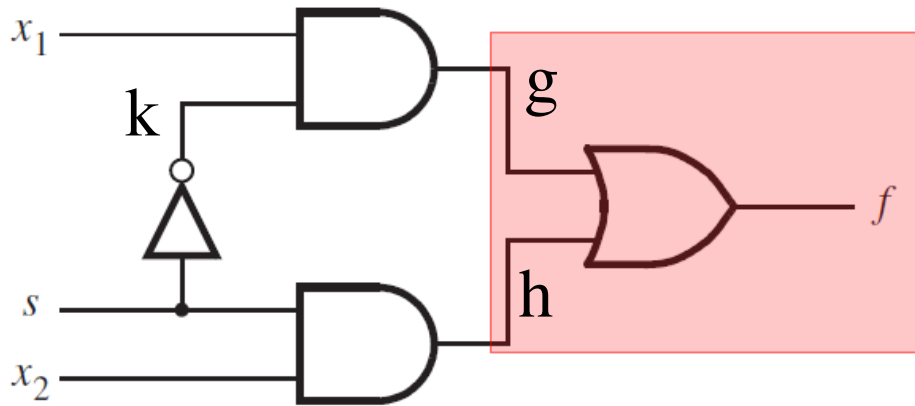

```
module example1 (x1, x2, s, f);  
  input x1, x2, s;  
  output f;  
  
  not (k, s);  
  and (g, k, x1);  
  and (h, s, x2);  
  or (f, g, h);  
  
endmodule
```

Behavioral Verilog

Verilog Code

Structural

Behavioral

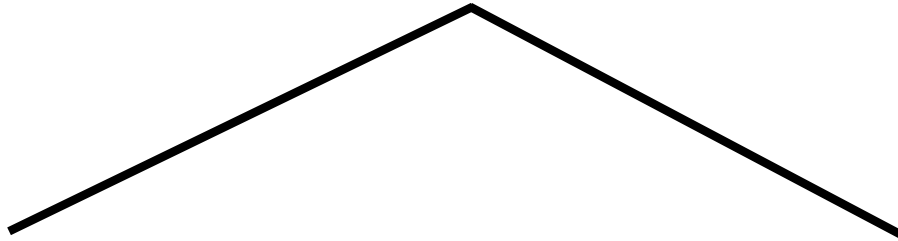

Verilog Code

Structural

Behavioral

Continuous

Procedural

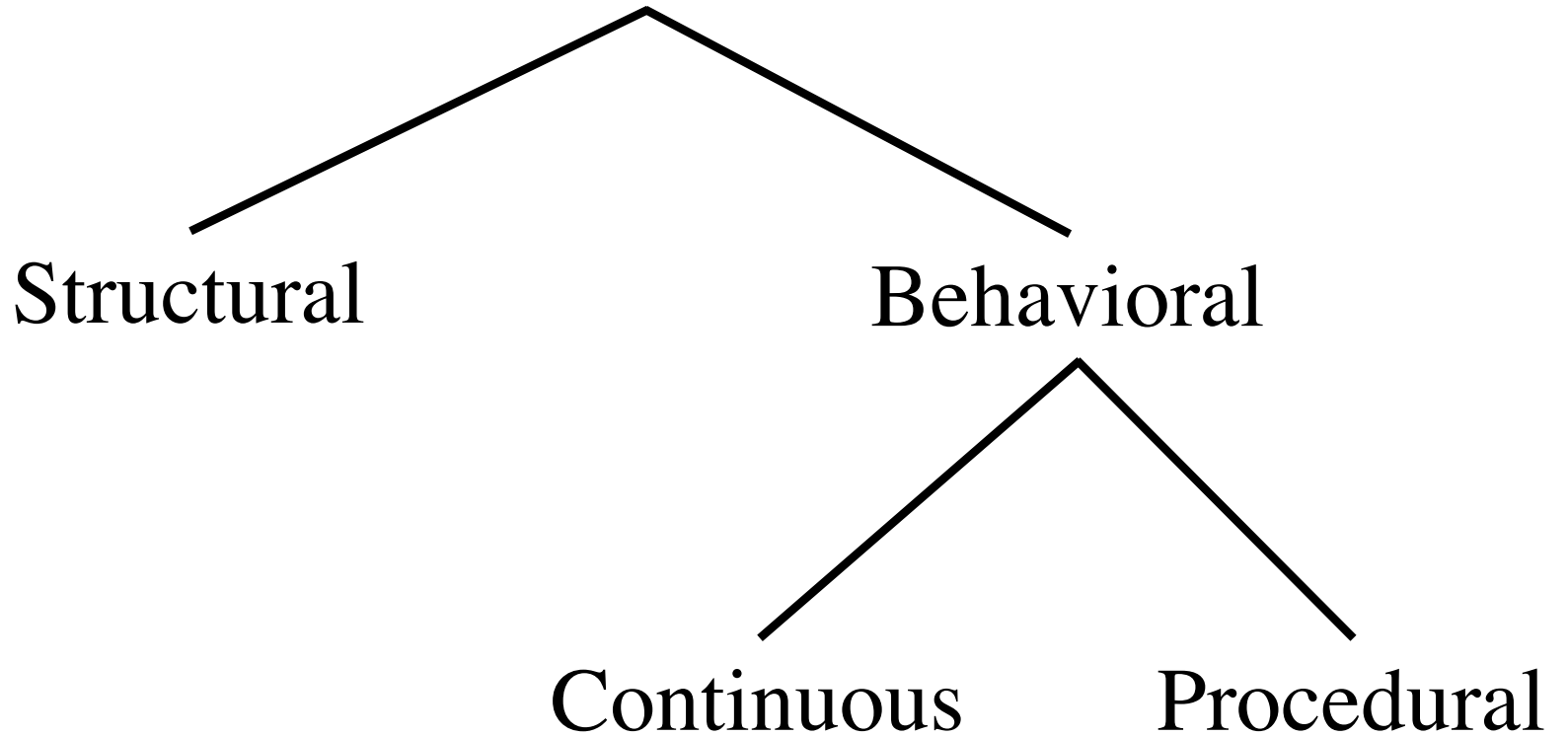

2-to-1 Multiplexer in Verilog (behavioral-continuous syntax)

Verilog Code for a 2-1 Multiplexer

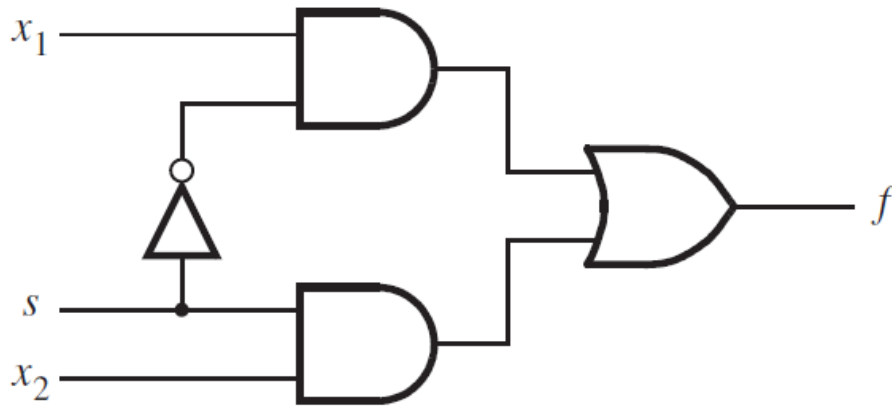

// Behavioral-Continuous specification

```
module example3 (x1, x2, s, f);
```

```
  input x1, x2, s;
```

```
  output f;
```

```
  assign f = (~s & x1) | (s & x2);
```

```
endmodule
```

Verilog Code for a 2-1 Multiplexer

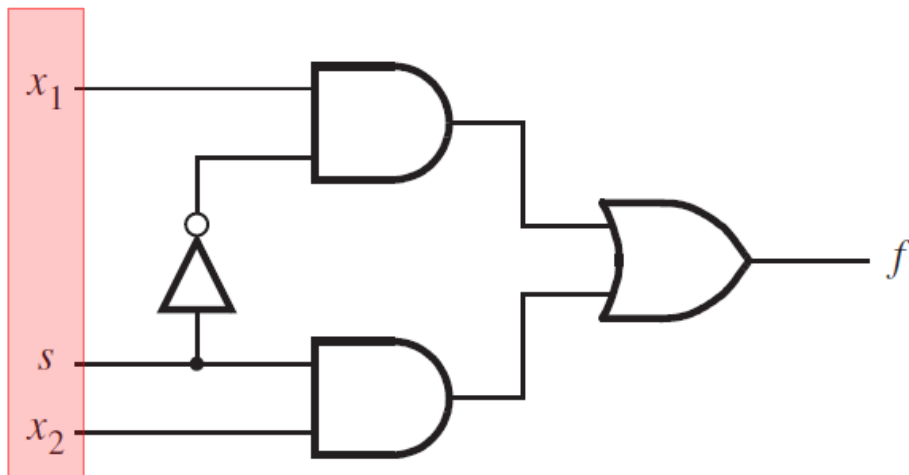

// Behavioral-Continuous specification

```
module example3 (x1, x2, s, f);
```

```
  input x1, x2, s;
```

```
  output f;
```

```
  assign f = ( $\sim$ s & x1) | (s & x2);
```

```
endmodule
```

Verilog Code for a 2-1 Multiplexer

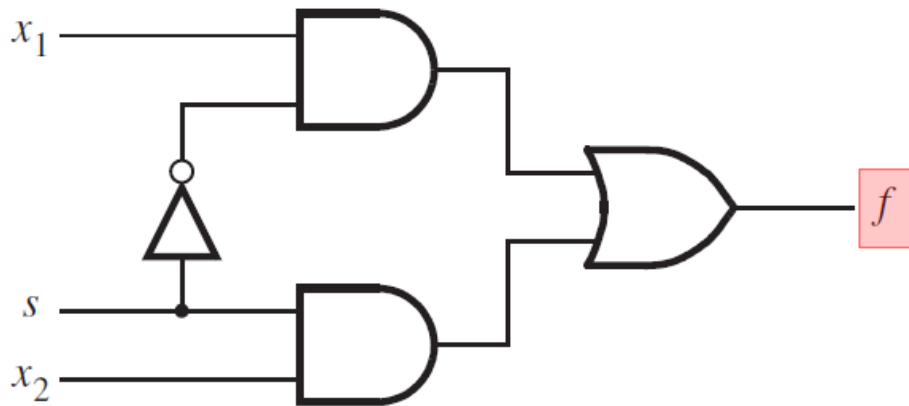

// Behavioral-Continuous specification

```
module example3 (x1, x2, s, f);
```

```
  input x1, x2, s;
```

```
  output f;
```

```
  assign f = (~s & x1) | (s & x2);
```

```
endmodule
```

Verilog Code for a 2-1 Multiplexer

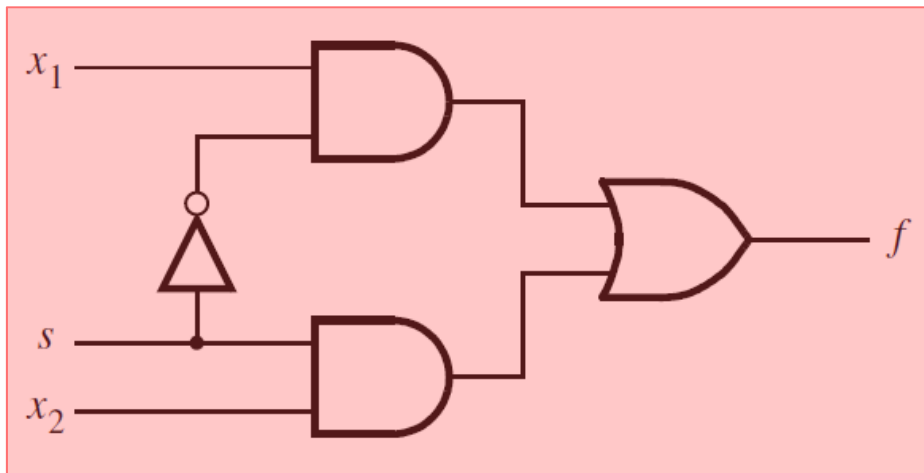

// Behavioral-Continuous specification

```
module example3 (x1, x2, s, f);
```

```
  input x1, x2, s;
```

```
  output f;
```

```
  assign f = (~s & x1) | (s & x2);
```

```
endmodule
```

2-to-1 Multiplexor in Verilog (behavioral-procedural specification)

Verilog Code for a 2-1 Multiplexer

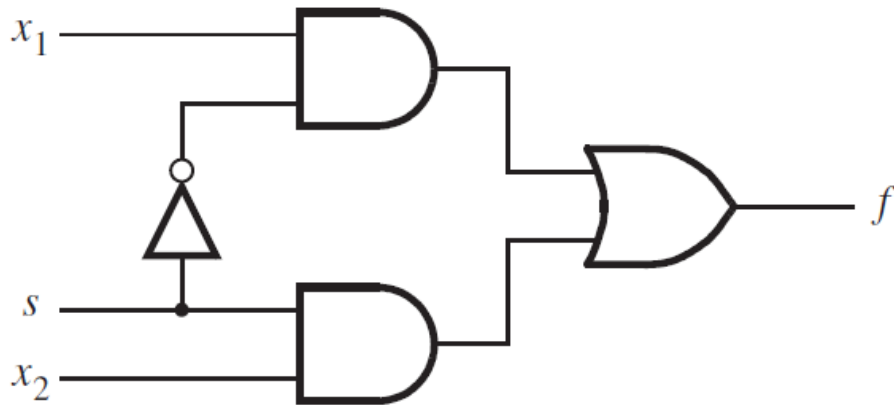

[Figure 2.36 from the textbook]

// Behavioral-Procedural specification

```
module example5 (x1, x2, s, f);  
  input x1, x2, s;  
  output f;  1  
  reg f;  
  
  always @(x1 or x2 or s)  
    if (s == 0)  
      f = x1;  
    else  
      f = x2;  
  
endmodule
```

[Figure 2.42 from the textbook]

Verilog Code for a 2-1 Multiplexer

A 2-to-1 Multiplexer has:

- **one output f**
- **two inputs: x_1 and x_2**
- **It also has another input line s**
- **If $s=0$, then the output is equal to x_1**
- **If $s=1$, then the output is equal to x_2**

// Behavioral-Procedural specification

```
module example5 (x1, x2, s, f);  
  input x1, x2, s;  
  output f;  1  
  reg f;  
  
  always @(x1 or x2 or s)  
    if (s == 0)  
      f = x1;  
    else  
      f = x2;  
  
endmodule
```

Verilog Code for a 2-1 Multiplexer

A 2-to-1 Multiplexer has:

- one output f
- two inputs: x_1 and x_2
- It also has another input line s
- If $s=0$, then the output is equal to x_1
- If $s=1$, then the output is equal to x_2

// Behavioral-Procedural specification

```
module example5 (x1, x2, s, f);  
    input x1, x2, s;  
    output f;  
    reg f;
```

```
    always @(x1 or x2 or s)  
        if (s == 0)  
            f = x1;  
        else  
            f = x2;
```

```
endmodule
```

always@ syntax

always @(x,y)

always @(x or y)

always @(*)

always @*

Verilog Code for a 2-1 Multiplexer

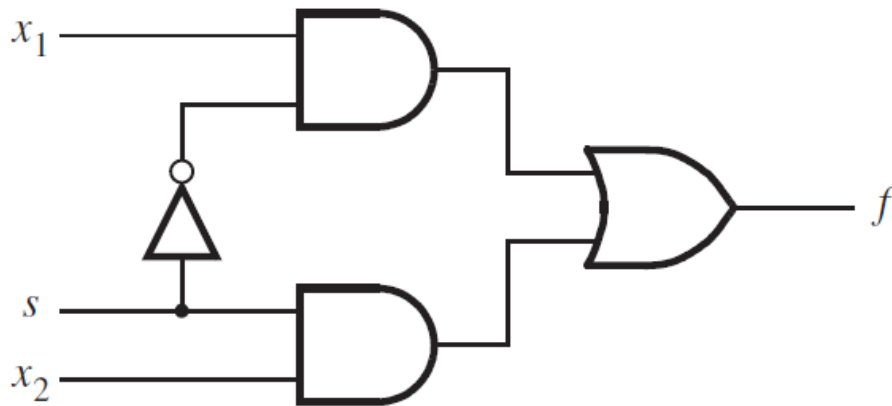

```
// Behavioral-Procedural specification
module example5 (input x1, x2, s, output reg f);

    always @(x1, x2, s)
        if (s == 0)
            f = x1;
        else
            f = x2;

endmodule
```

Structural v.s. Behavioral

Verilog Code: Structural v.s. Behavioral

```
// Structural specification
module example1 (x1, x2, s, f);
    input x1, x2, s;
    output f;

    not (k, s);
    and (g, k, x1);
    and (h, s, x2);
    or (f, g, h);

endmodule
```

[Figure 2.37 from the textbook]

```
// Behavioral-Continuous specification
module example3 (x1, x2, s, f);
    input x1, x2, s;
    output f;

    assign f = (~s & x1) | (s & x2);

endmodule
```

[Figure 2.40 from the textbook]

Verilog Code: Structural v.s. Behavioral

```
// Structural specification
module example1 (x1, x2, s, f);
    input x1, x2, s;
    output f;

    not (k, s);
    and (g, k, x1);
    and (h, s, x2);
    or (f, g, h);

endmodule
```

[Figure 2.37 from the textbook]

```
// Behavioral-Procedural specification
module example5 (x1, x2, s, f);
    input x1, x2, s;
    output f;
    reg f;

    always @(x1 or x2 or s)
        if (s == 0)
            f = x1;
        else
            f = x2;

endmodule
```

[Figure 2.42 from the textbook]

Behavioral Verilog: Continuous v.s. Procedural

```
// Behavioral-Continuous specification
module example3 (x1, x2, s, f);
  input x1, x2, s;
  output f;

  assign f = (~s & x1) | (s & x2);

endmodule
```

[Figure 2.40 from the textbook]

```
// Behavioral-Procedural specification
module example5 (x1, x2, s, f);
  input x1, x2, s;
  output f;
  reg f;

  always @(x1 or x2 or s)
    if (s == 0)
      f = x1;
    else
      f = x2;

endmodule
```

[Figure 2.42 from the textbook]

Verilog Code

```
graph TD; A[Verilog Code] --> B[Structural]; A --> C[Behavioral]; B --- D["(basic components)"]; C --> E[Continuous]; C --> F[Procedural]; E --- G["(assign statements)"]; F --- H["(always statements)"];
```

Structural

(basic components)

Behavioral

Continuous

(assign statements)

Procedural

(always statements)

Another Example

Let's Write the Code for This Circuit

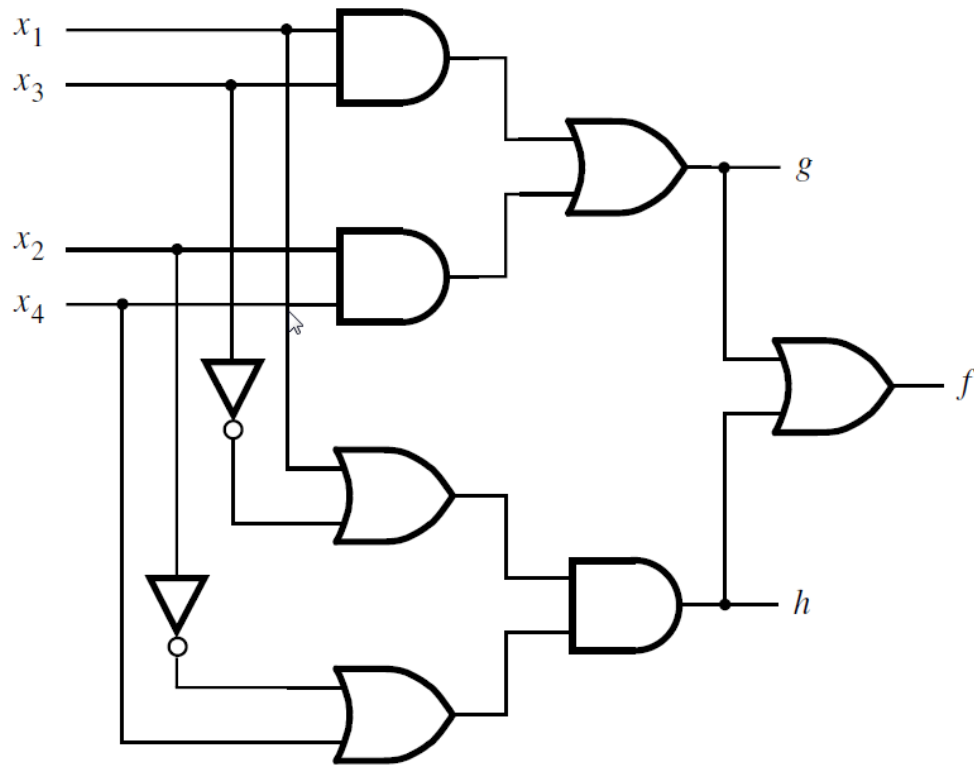

[Figure 2.39 from the textbook]

Structural Verilog

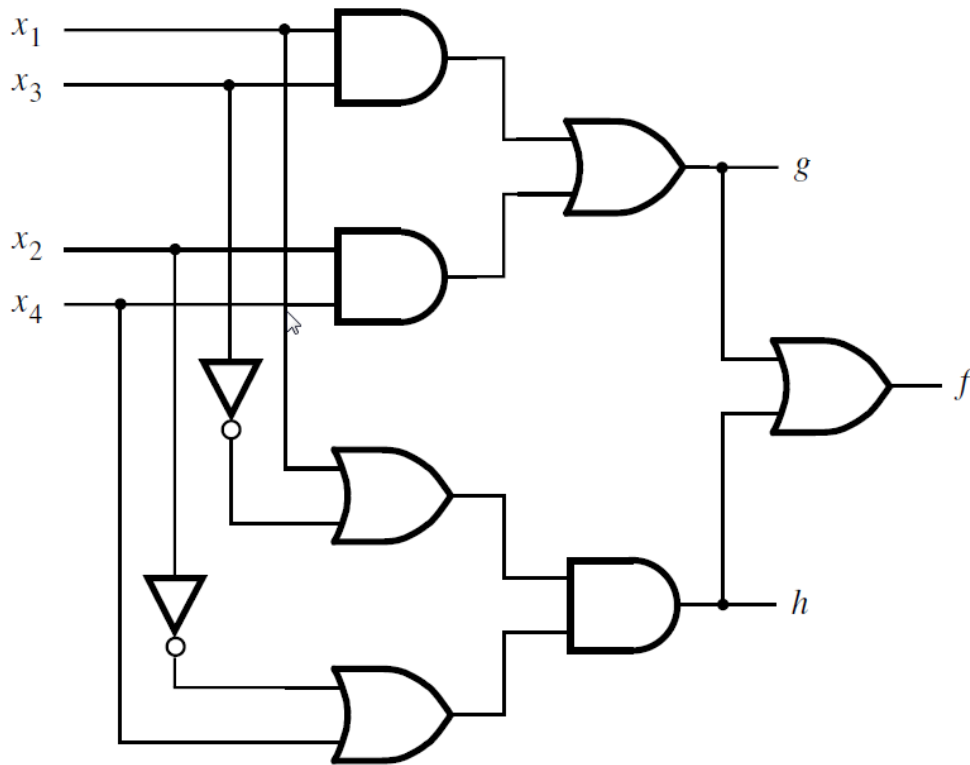

```
module example2 (x1, x2, x3, x4, f, g, h);  
    input x1, x2, x3, x4;  
    output f, g, h;  
  
    and (z1, x1, x3);  
    and (z2, x2, x4);  
    or (g, z1, z2);  
    or (z3, x1, ~x3);  
    or (z4, ~x2, x4);  
    and (h, z3, z4);  
    or (f, g, h);  
  
endmodule
```

Structural Verilog

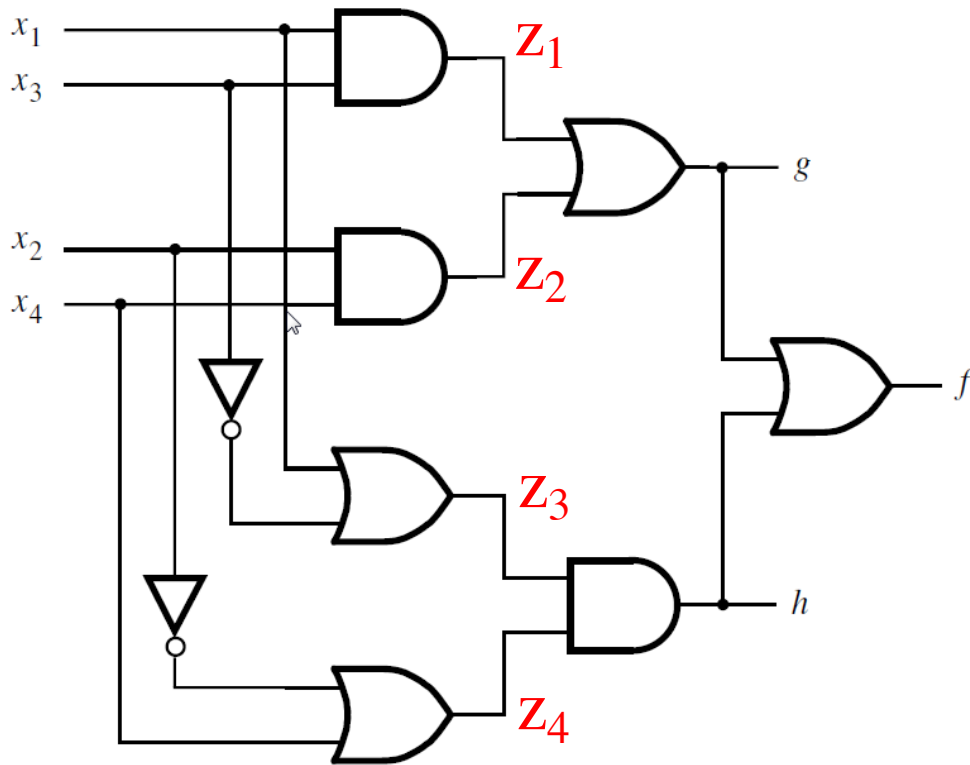

```
module example2 (x1, x2, x3, x4, f, g, h);  
  input x1, x2, x3, x4;  
  output f, g, h;  
  
  and (z1, x1, x3);  
  and (z2, x2, x4);  
  or (g, z1, z2);  
  or (z3, x1, ~x3);  
  or (z4, ~x2, x4);  
  and (h, z3, z4);  
  or (f, g, h);  
  
endmodule
```

Behavioral Verilog

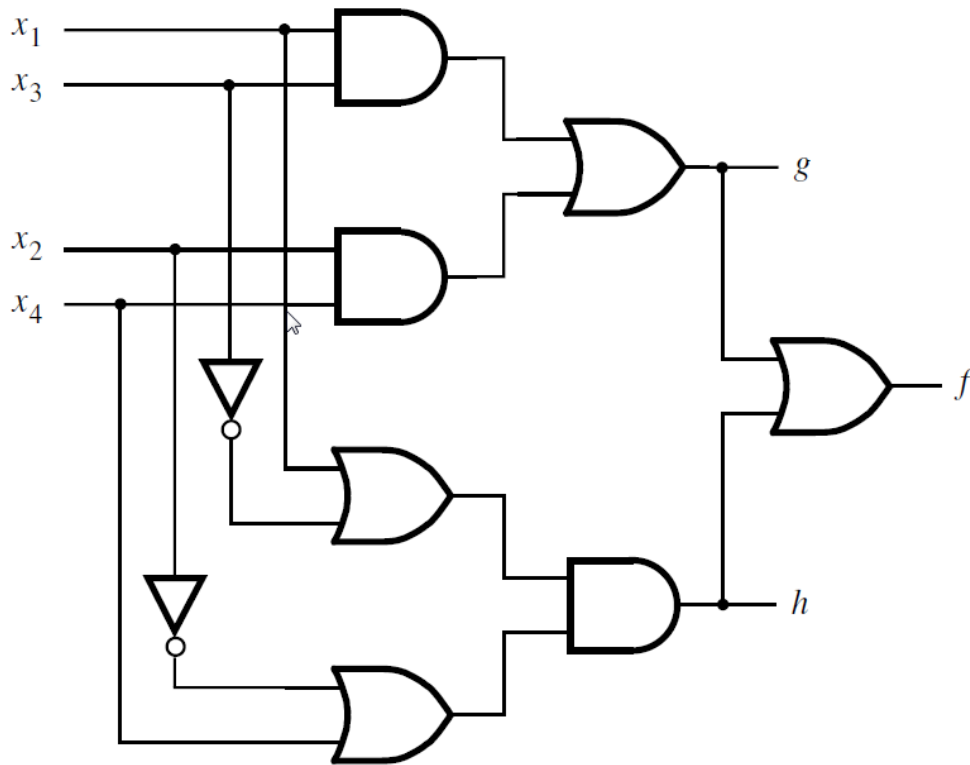

```
module example4 (x1, x2, x3, x4, f, g, h);  
  input x1, x2, x3, x4;  
  output f, g, h;  
  
  assign g = (x1 & x3) | (x2 & x4);  
  assign h = (x1 | ~x3) & (~x2 | x4);  
  assign f = g | h;  
  
endmodule
```

Structural v.s. Behavioral

```
module example2 (x1, x2, x3, x4, f, g, h);  
    input x1, x2, x3, x4;  
    output f, g, h;  
  
    and (z1, x1, x3);  
    and (z2, x2, x4);  
    or (g, z1, z2);  
    or (z3, x1, ~x3);  
    or (z4, ~x2, x4);  
    and (h, z3, z4);  
    or (f, g, h);  
  
endmodule
```

// structural

```
module example4 (x1, x2, x3, x4, f, g, h);  
    input x1, x2, x3, x4;  
    output f, g, h;  
  
    assign g = (x1 & x3) | (x2 & x4);  
    assign h = (x1 | ~x3) & (~x2 | x4);  
    assign f = g | h;  
  
endmodule
```

// behavioral-continuous

Yet Another Example

A logic circuit with two modules

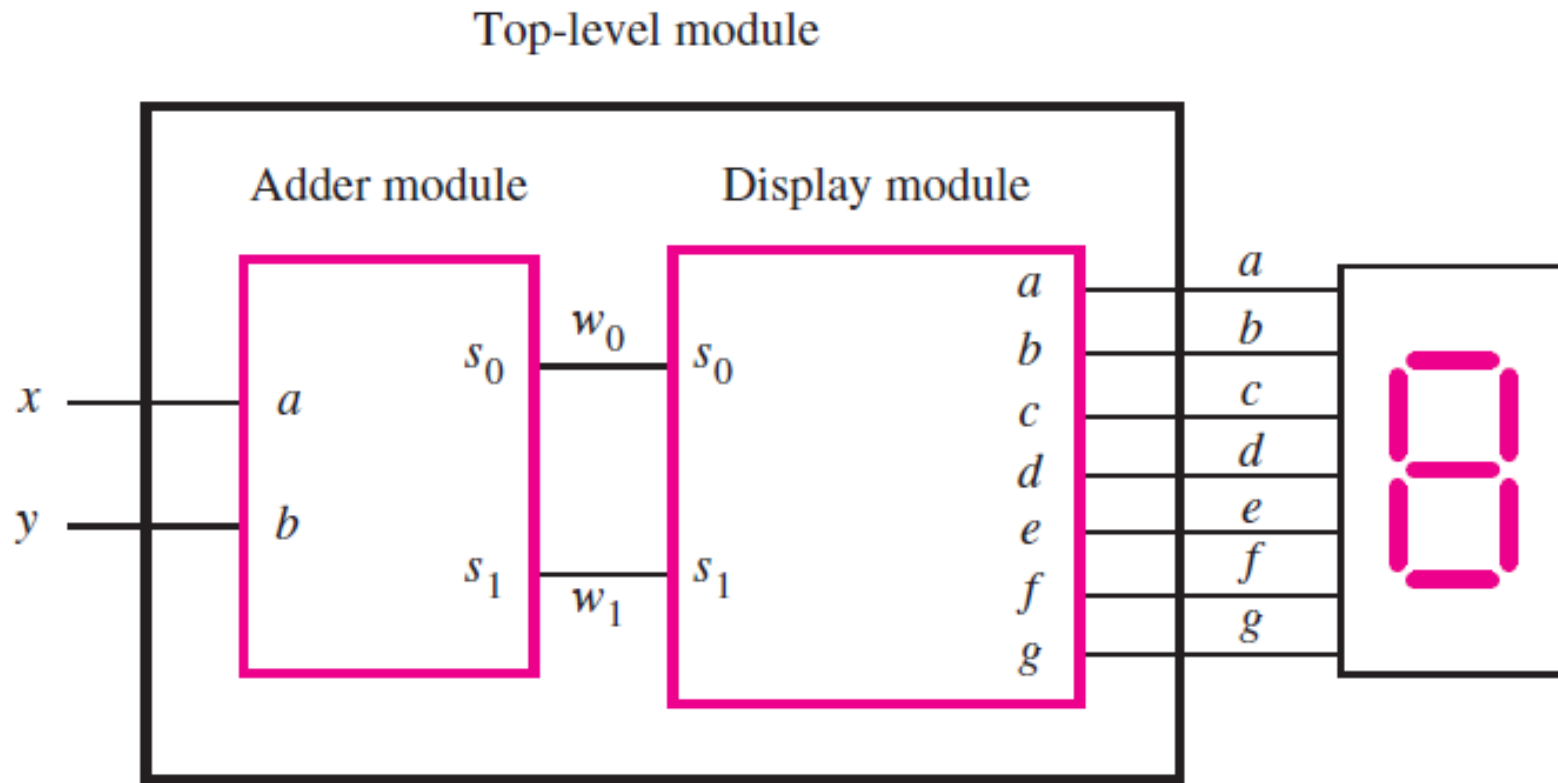

The adder module

a	0	0	1	1
$+b$	$+0$	$+1$	$+0$	$+1$
$s_1 s_0$	0 0	0 1	0 1	1 0

(a) Evaluation of $S = a + b$

a	b	s_1	s_0
0	0	0	0
0	1	0	1
1	0	0	1
1	1	1	0

(b) Truth table

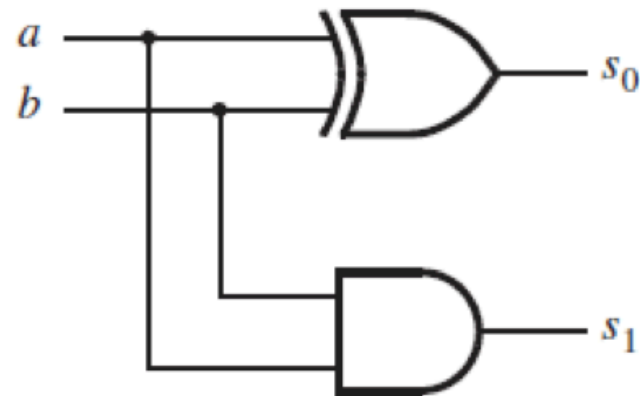

(c) Logic network

The adder module

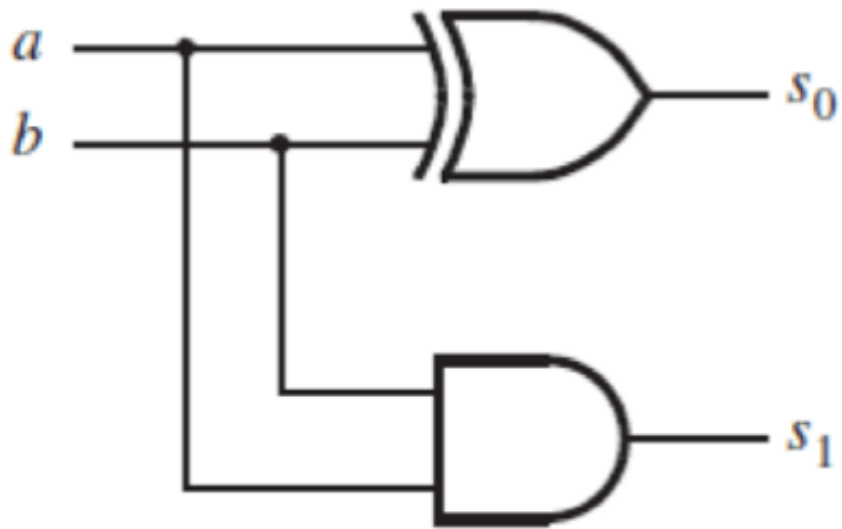

```
// An adder module
module adder (a, b, s1, s0);
  input a, b;
  output s1, s0;

  assign s1 = a & b;
  assign s0 = a ^ b;

endmodule
```

The display module

	s_1	s_0	a	b	c	d	e	f	g
0	0	0	1	1	1	1	1	1	0
1	0	1	0	1	1	0	0	0	0
2	1	0	1	1	0	1	1	0	1

$$a = \overline{s_0}$$

$$c = \overline{s_1}$$

$$e = \overline{s_0}$$

$$g = s_1 \overline{s_0}$$

$$b = 1$$

$$d = \overline{s_0}$$

$$f = \overline{s_1} \overline{s_0}$$

The display module

$$a = \overline{s_0}$$

$$b = 1$$

$$c = \overline{s_1}$$

$$d = \overline{s_0}$$

$$e = \overline{s_0}$$

$$f = \overline{s_1} \overline{s_0}$$

$$g = s_1 \overline{s_0}$$

```
// A module for driving a 7-segment display
module display (s1, s0, a, b, c, d, e, f, g);
    input s1, s0;
    output a, b, c, d, e, f, g;

    assign a = ~s0;
    assign b = 1;
    assign c = ~s1;
    assign d = ~s0;
    assign e = ~s0;
    assign f = ~s1 & ~s0;
    assign g = s1 & ~s0;

endmodule
```

Putting it all together

Top-level module

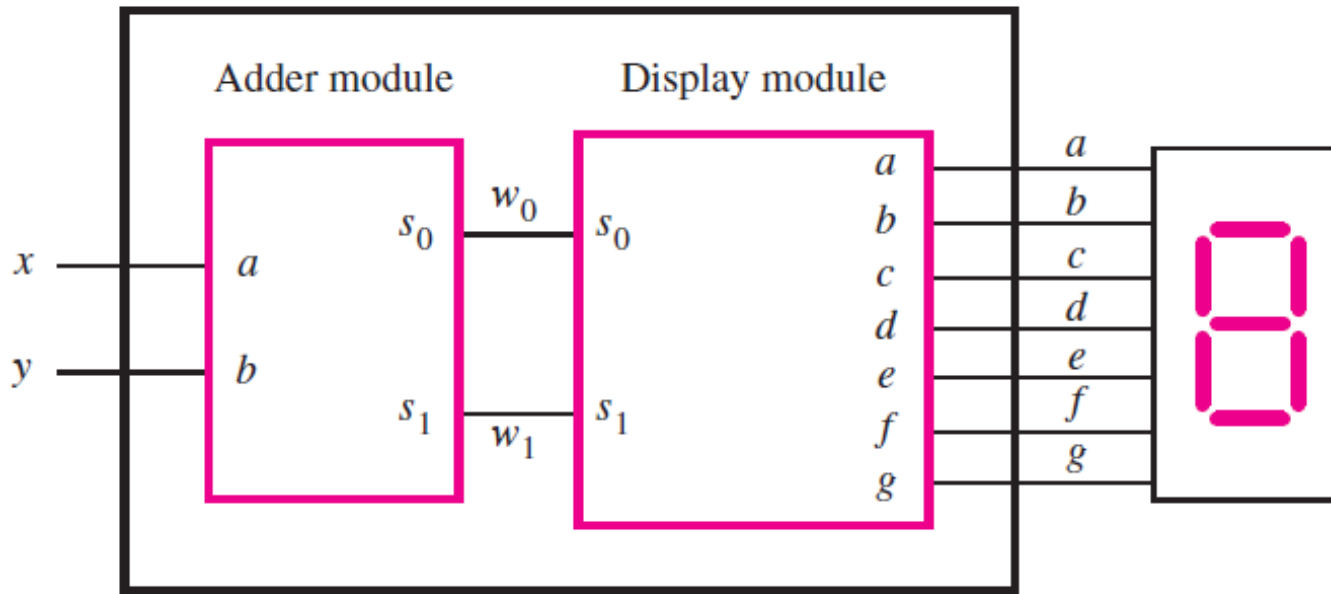

```
// An adder module
module adder (a, b, s1, s0)
  input a, b;
  output s1, s0;

  assign s1 = a & b;
  assign s0 = a ^ b;

endmodule
```

```
// A module for driving a 7-segment display
module display (s1, s0, a, b, c, d, e, f, g);
  input s1, s0;
  output a, b, c, d, e, f, g;

  assign a = ~s0;
  assign b = 1;
  assign c = ~s1;
  assign d = ~s0;
  assign e = ~s0;
  assign f = ~s1 & ~s0;
  assign g = s1 & ~s0;

endmodule
```

```
module adder_display (x, y, a, b, c, d, e, f, g);
  input x, y;
  output a, b, c, d, e, f, g;
  wire w1, w0;

  adder U1 (x, y, w1, w0);
  display U2 (w1, w0, a, b, c, d, e, f, g);

endmodule
```

Putting it all together

Top-level module

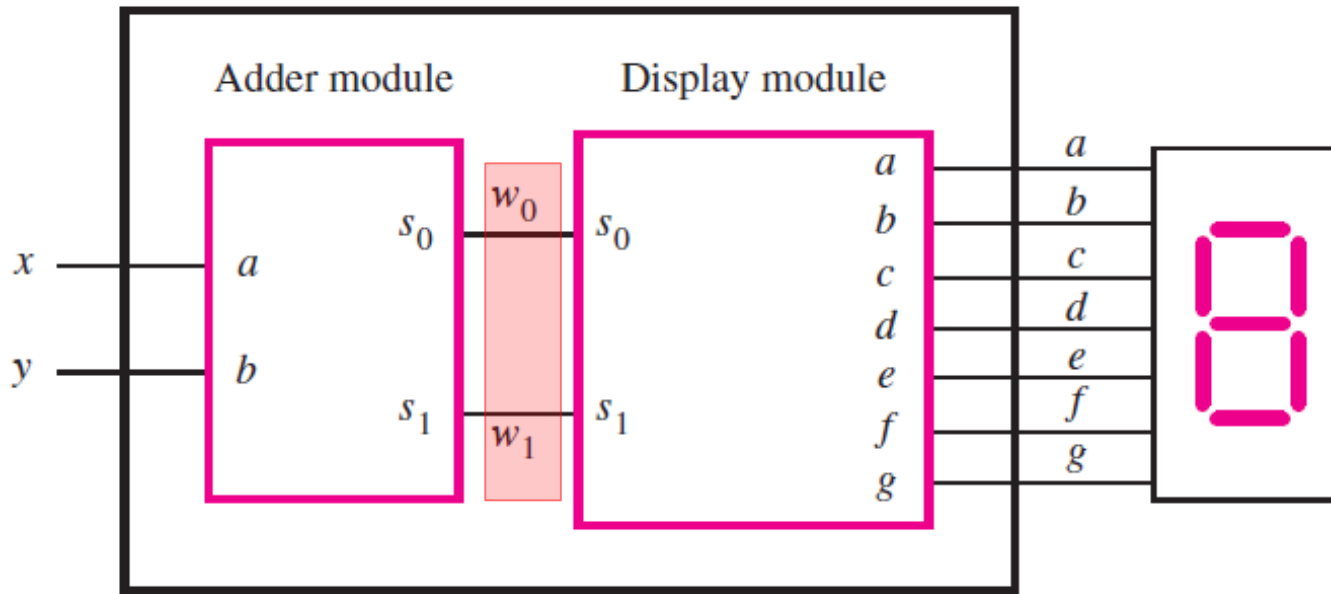

```
// An adder module
module adder (a, b, s1, s0)
  input a, b;
  output s1, s0;

  assign s1 = a & b;
  assign s0 = a ^ b;

endmodule
```

```
// A module for driving a 7-segment display
module display (s1, s0, a, b, c, d, e, f, g);
  input s1, s0;
  output a, b, c, d, e, f, g;

  assign a = ~s0;
  assign b = 1;
  assign c = ~s1;
  assign d = ~s0;
  assign e = ~s0;
  assign f = ~s1 & ~s0;
  assign g = s1 & ~s0;

endmodule
```

```
module adder_display (x, y, a, b, c, d, e, f, g);
  input x, y;
  output a, b, c, d, e, f, g;
  wire w1, w0;

  adder U1 (x, y, w1, w0);
  display U2 (w1, w0, a, b, c, d, e, f, g);

endmodule
```

Questions?

THE END