



CprE 281: Digital Logic

Instructor: Alexander Stoytchev

<http://www.ece.iastate.edu/~alexs/classes/>

Designing a Counter

(Using the Sequential Circuit Approach)

CprE 281: Digital Logic
Iowa State University, Ames, IA
Copyright © Alexander Stoytchev

Administrative Stuff

- **Homework 11 is due on Wednesday Nov. 16 @ 10pm**

Example:
Implement a modulo-8 counter

Mini Review

Asynchronous Counters

A three-bit down-counter

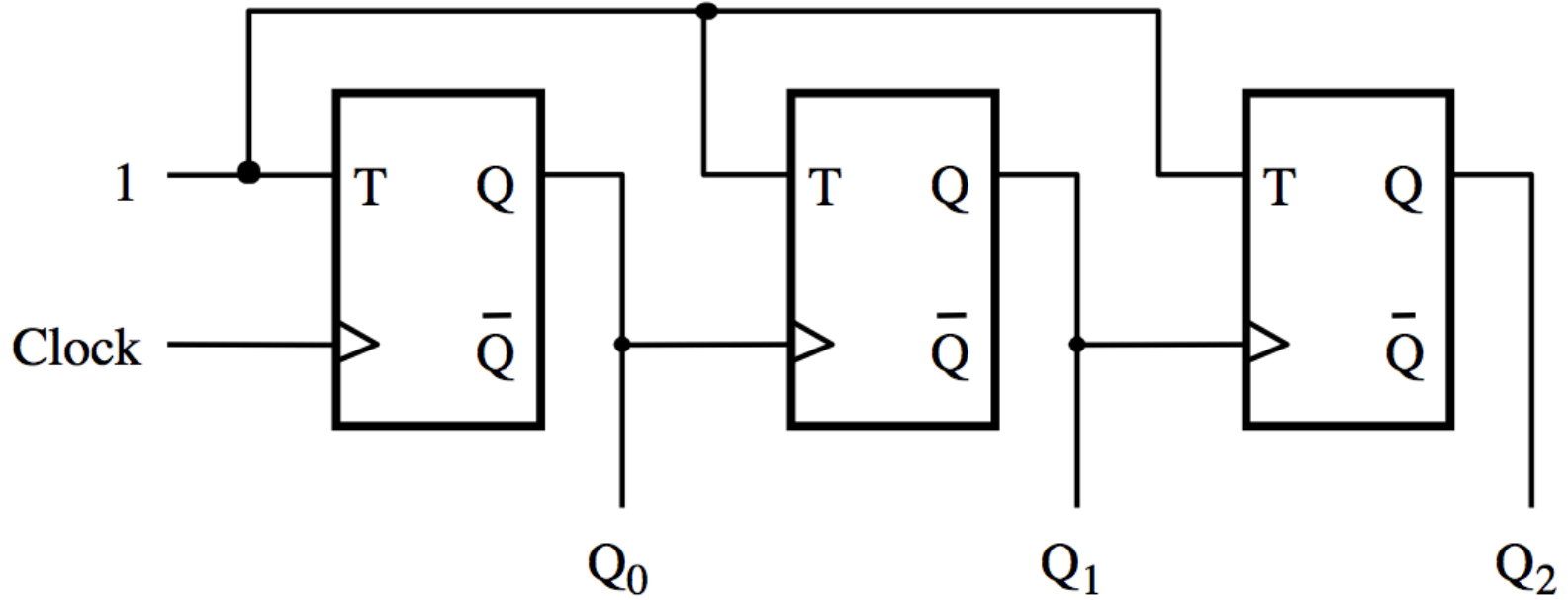

A three-bit down-counter

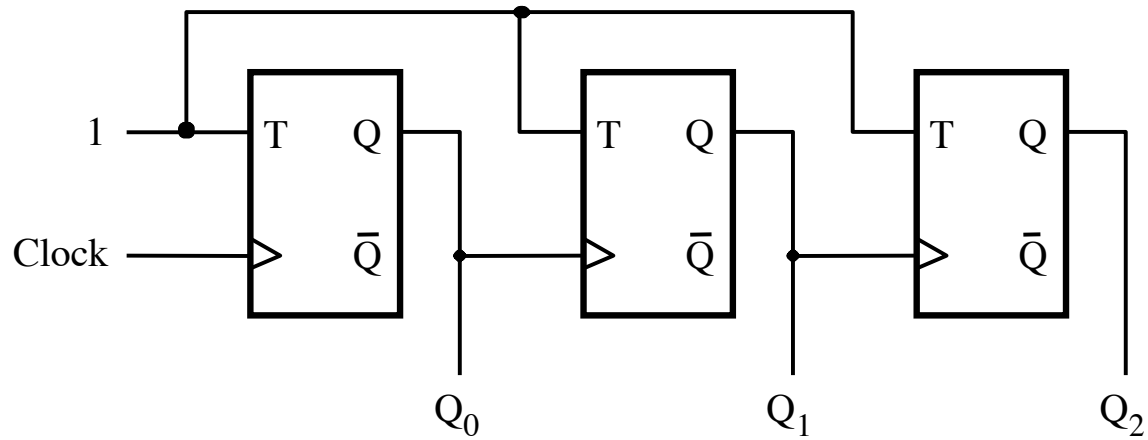

(a) Circuit

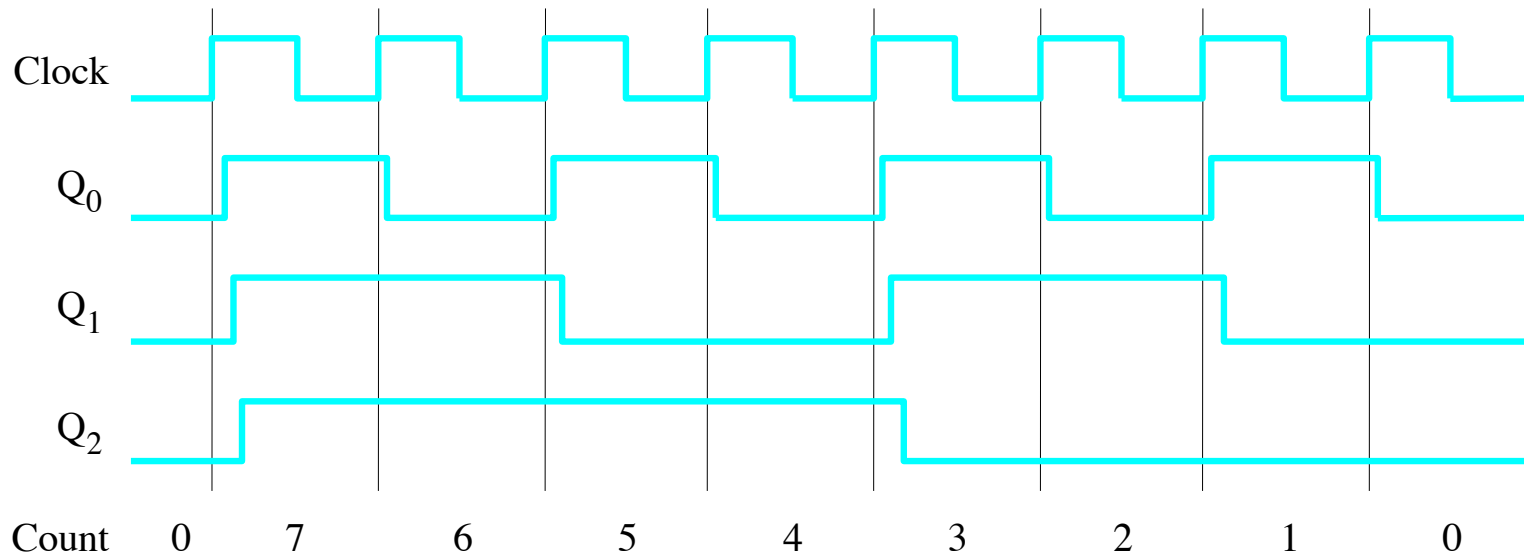

(b) Timing diagram

[Figure 5.20 from the textbook]

A three-bit down-counter

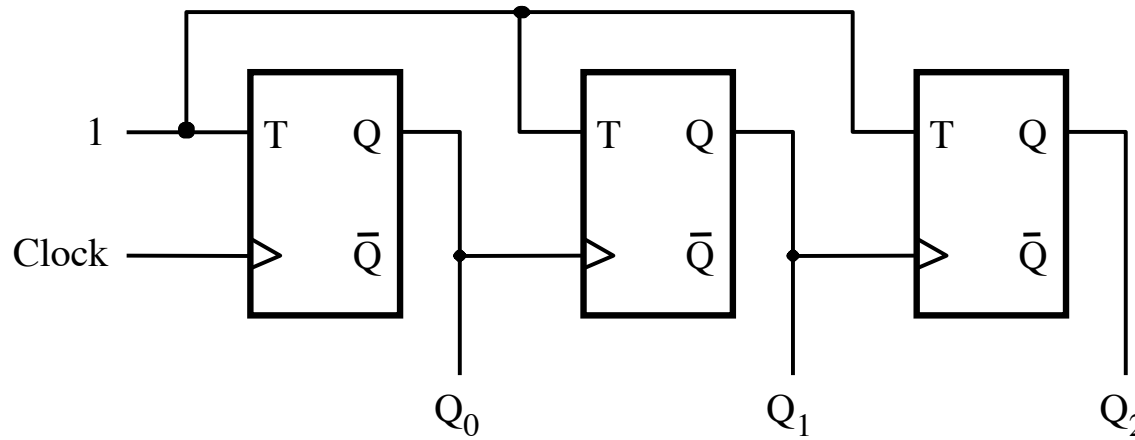

(a) Circuit

The propagation delays get longer

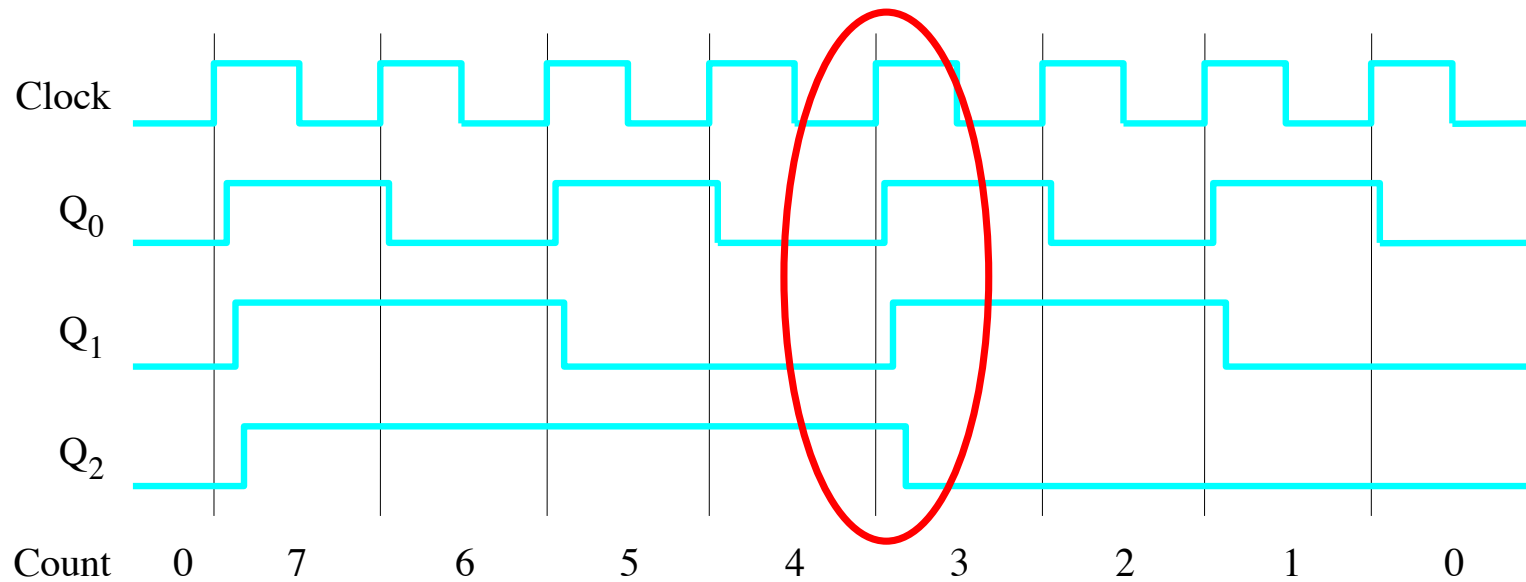

(b) Timing diagram

[Figure 5.20 from the textbook]

A three-bit up-counter

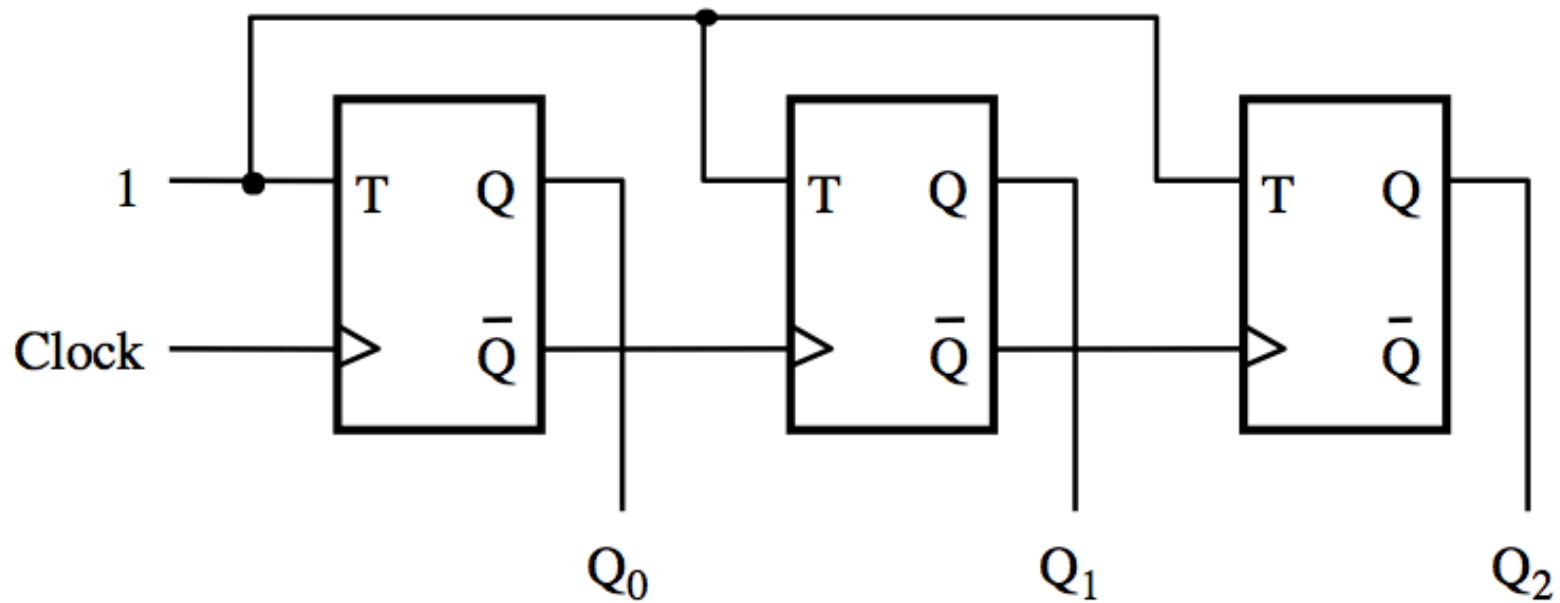

A three-bit up-counter

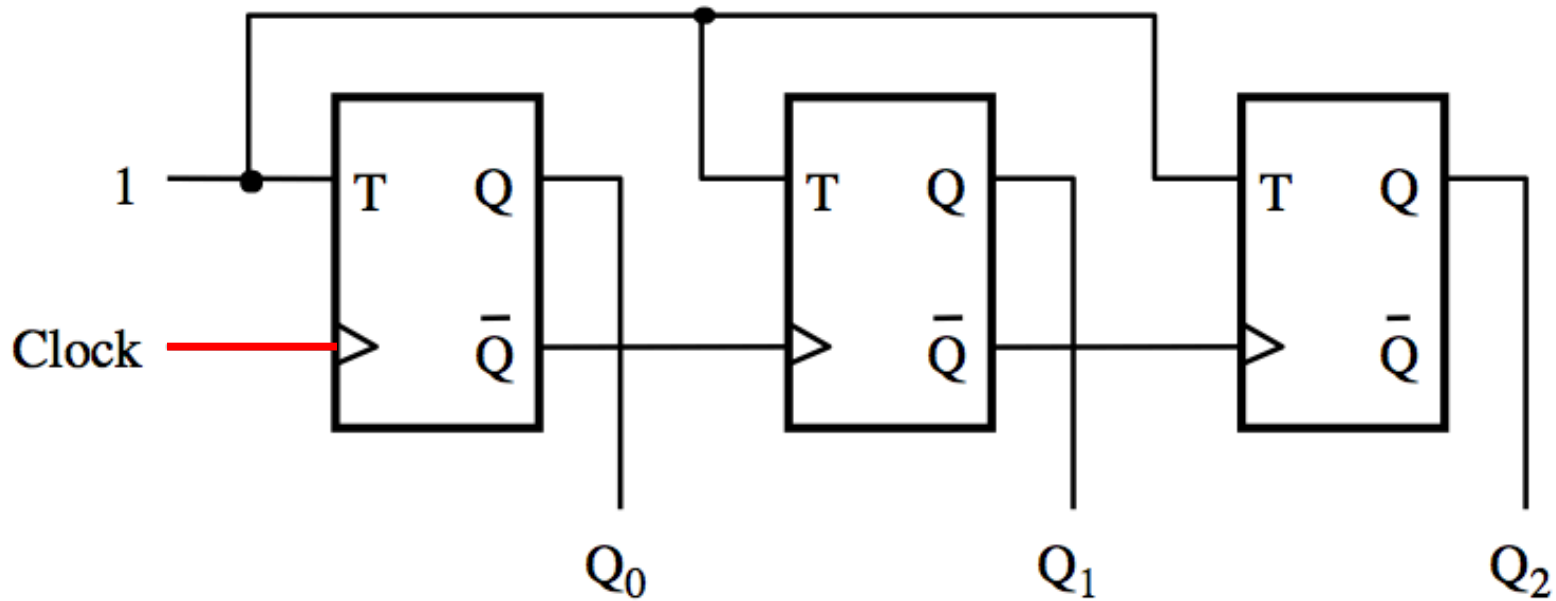

The first flip-flop changes
on the positive edge of the clock

A three-bit up-counter

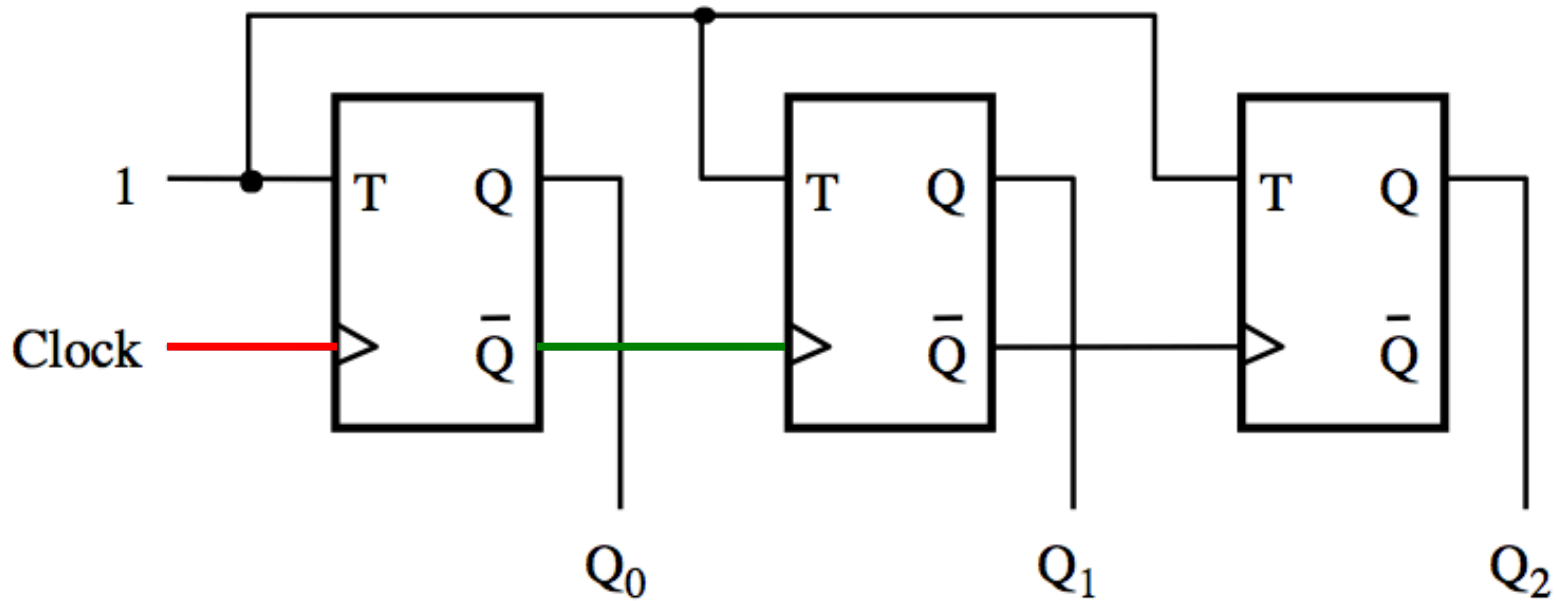

The first flip-flop changes on the positive edge of the clock

The second flip-flop changes on the positive edge of \bar{Q}_0

A three-bit up-counter

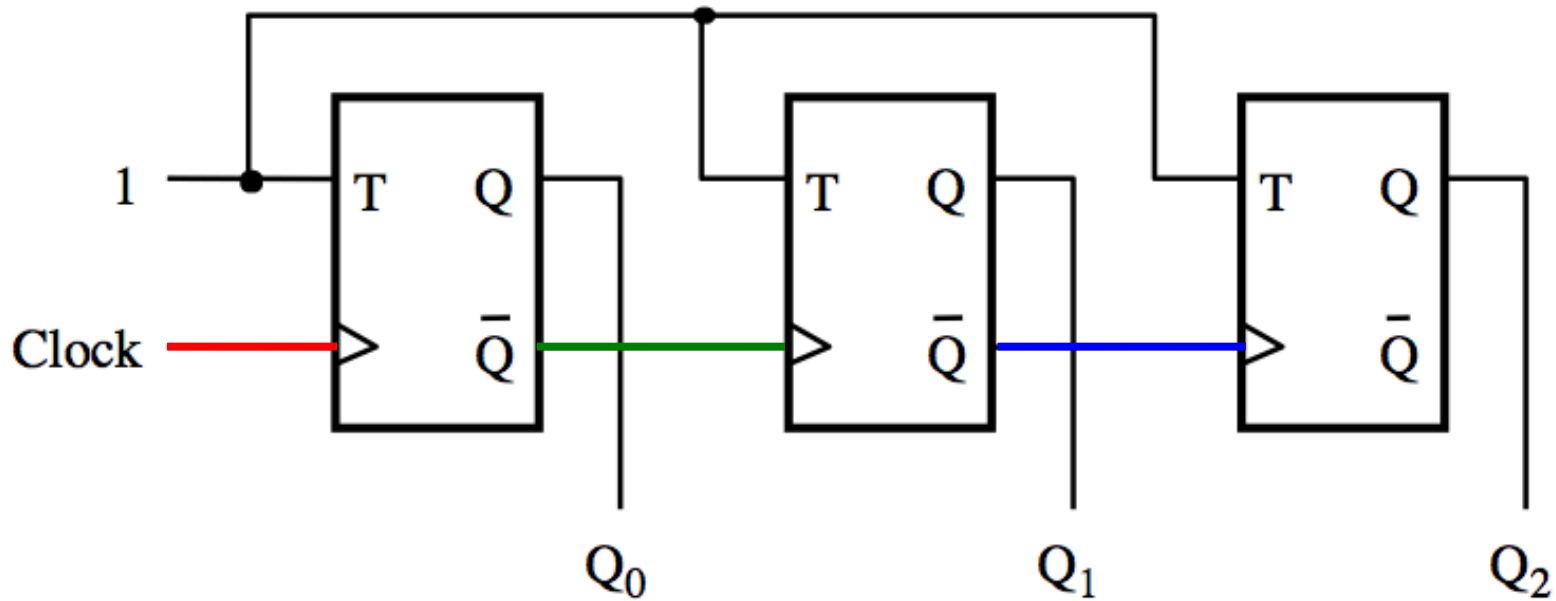

The first flip-flop changes on the positive edge of the clock

The second flip-flop changes on the positive edge of \bar{Q}_0

The third flip-flop changes on the positive edge of \bar{Q}_1

A three-bit up-counter

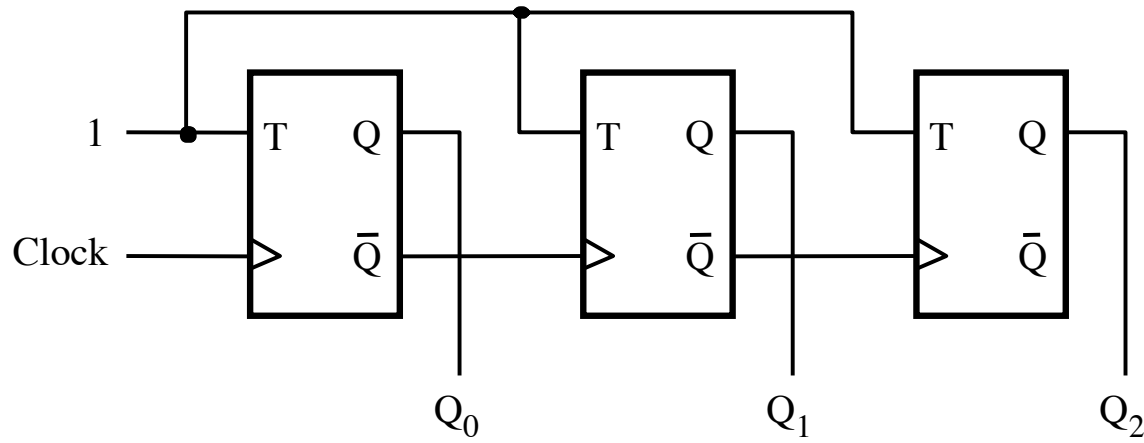

(a) Circuit

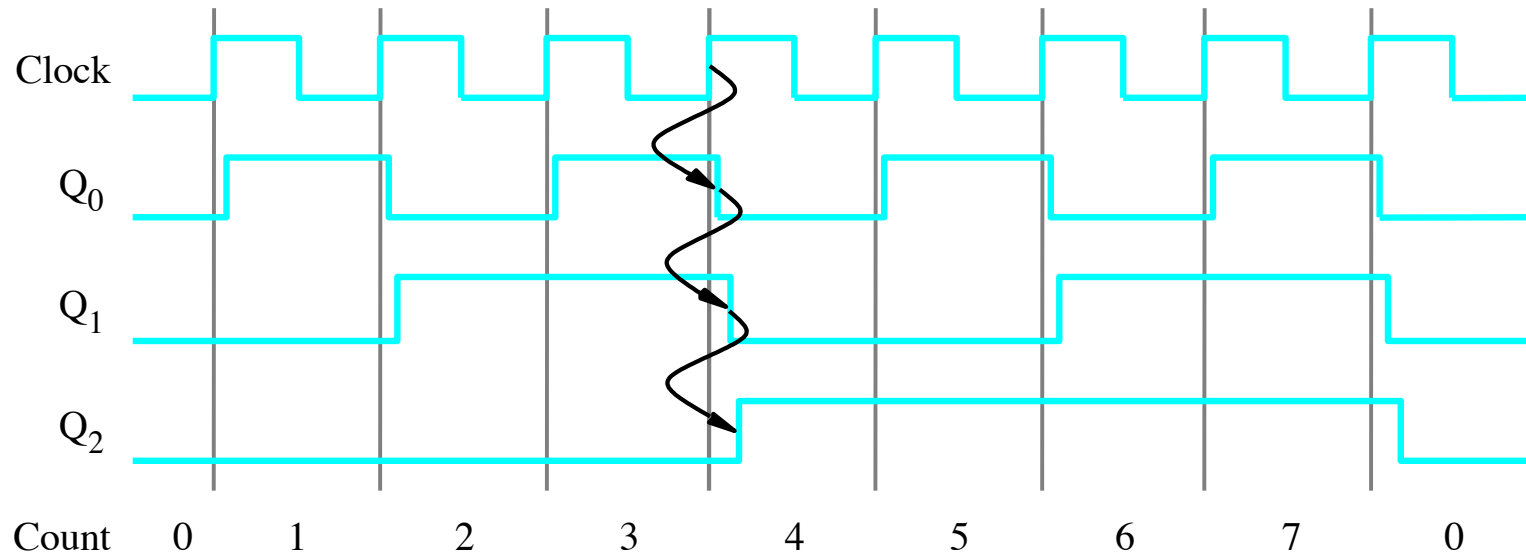

(b) Timing diagram

A three-bit up-counter

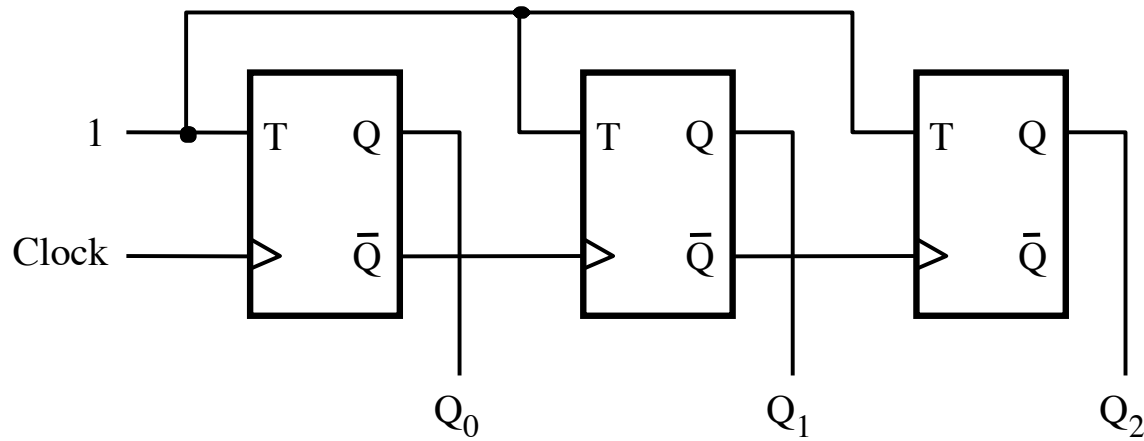

(a) Circuit

The propagation delays get longer

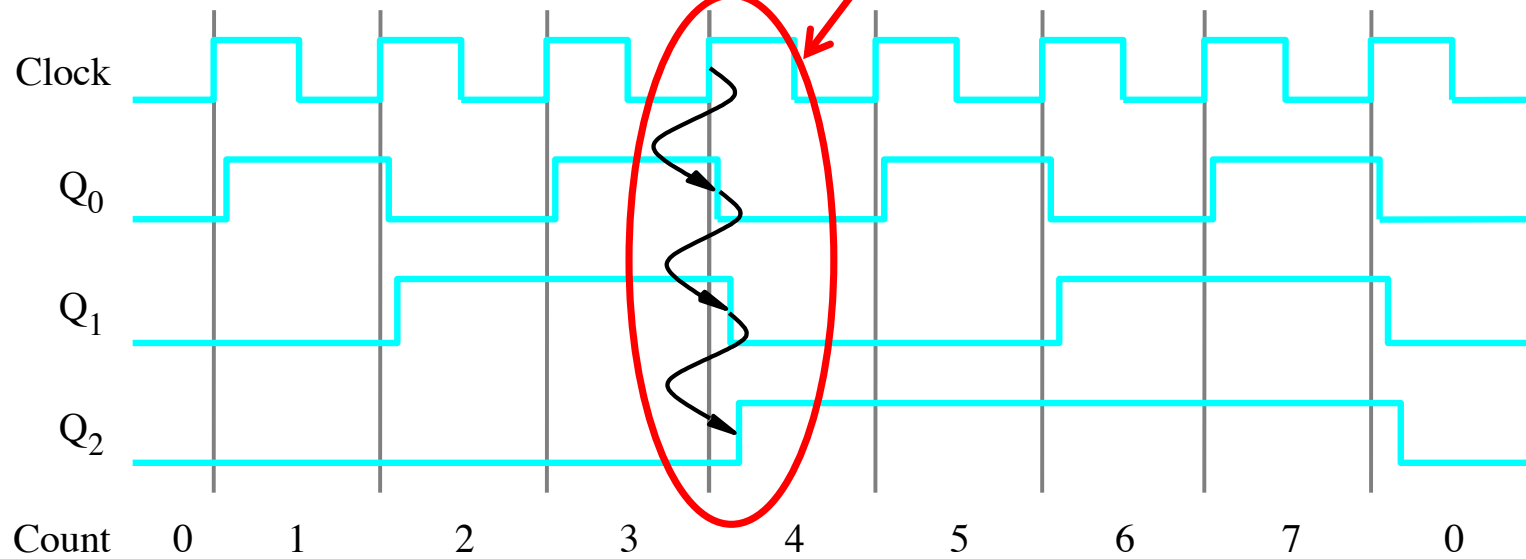

(b) Timing diagram

Synchronous Counters

A four-bit synchronous up-counter

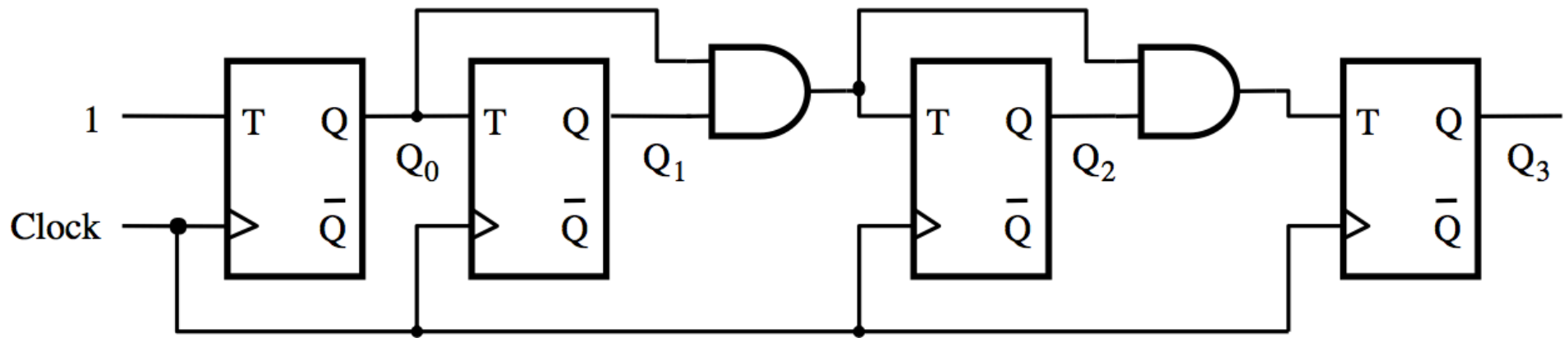

A four-bit synchronous up-counter

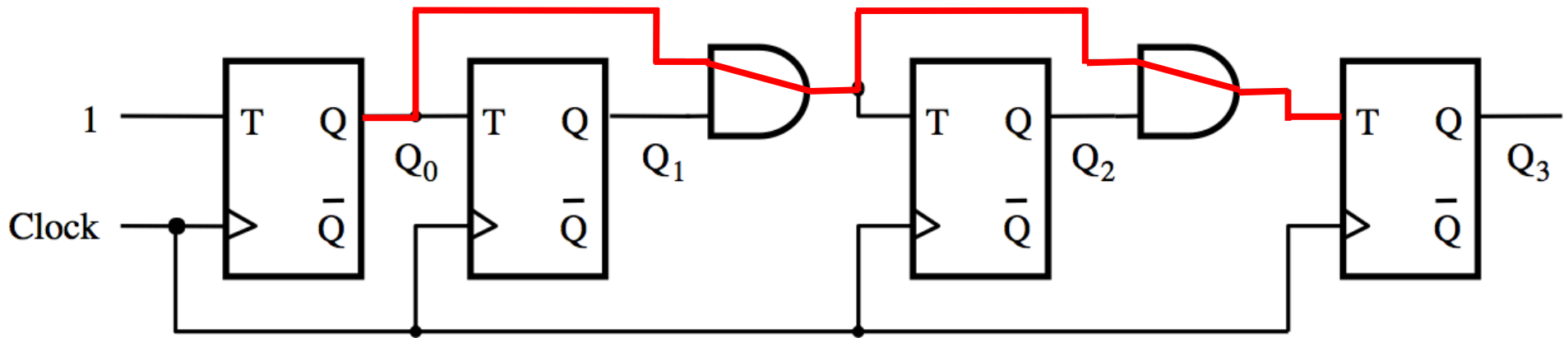

The propagation delay through all AND gates combined must not exceed the clock period minus the setup time for the flip-flops

A four-bit synchronous up-counter

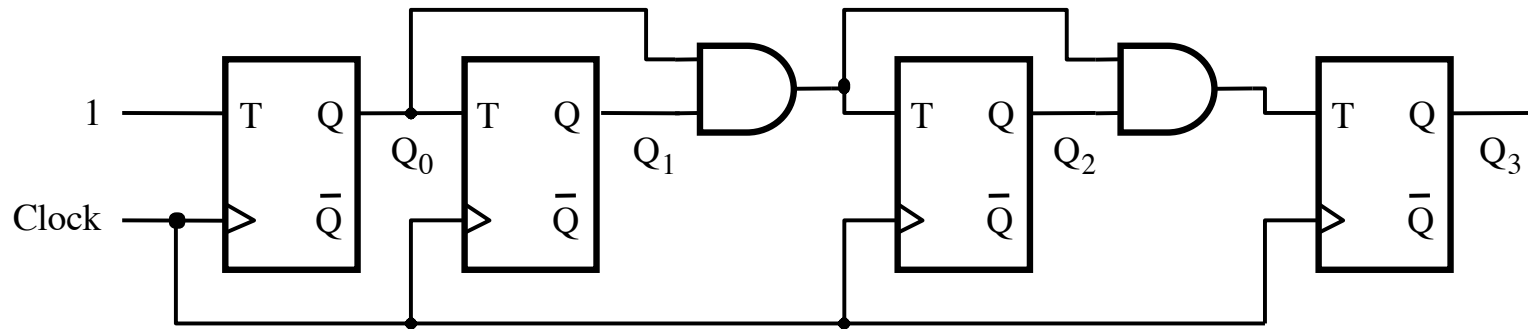

(a) Circuit

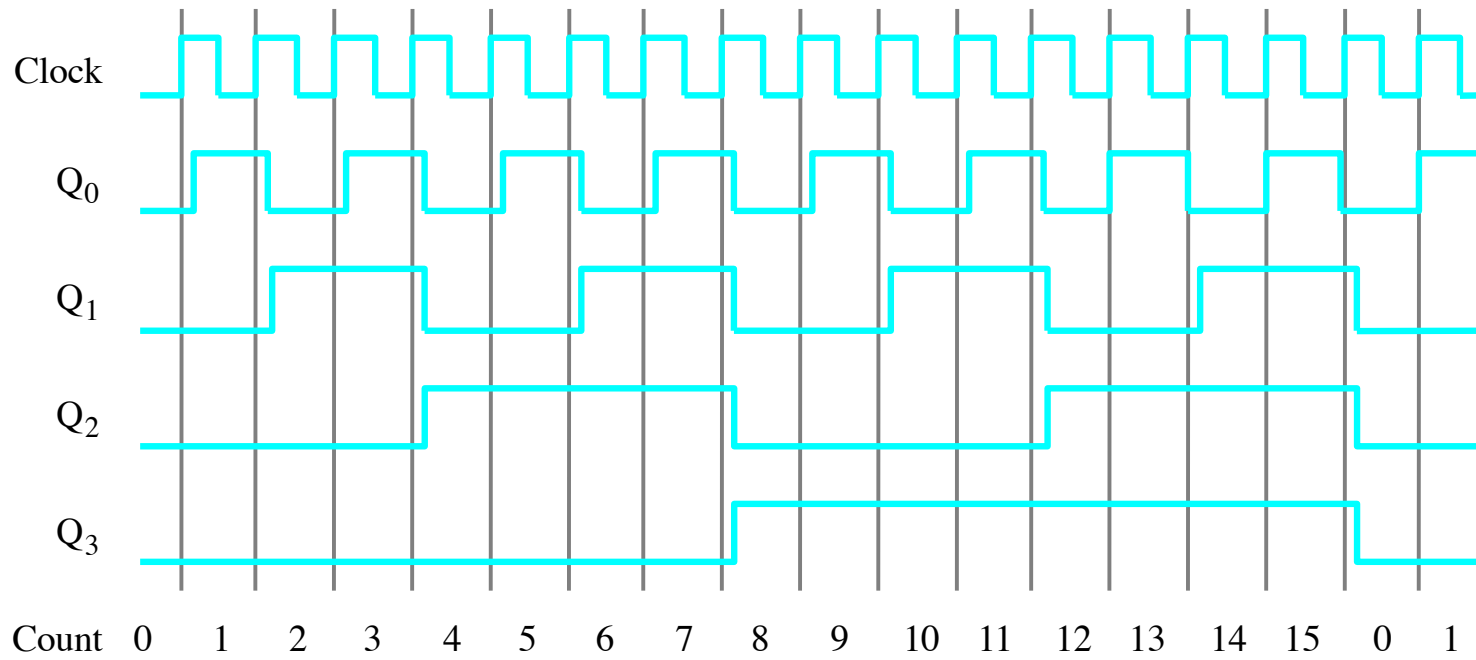

(b) Timing diagram

Derivation of the synchronous up-counter

Clock cycle	Q ₂	Q ₁	Q ₀
0	0	0	0
1	0	0	1
2	0	1	0
3	0	1	1
4	1	0	0
5	1	0	1
6	1	1	0
7	1	1	1
8	0	0	0

Q₁ changes

Q₂ changes

Derivation of the synchronous up-counter

Clock cycle	Q ₂	Q ₁	Q ₀
0	0	0	0
1	0	0	1
2	0	1	0
3	0	1	1
4	1	0	0
5	1	0	1
6	1	1	0
7	1	1	1
8	0	0	0

$$T_0 = 1$$

$$T_1 = Q_0$$

$$T_2 = Q_0 Q_1$$

A four-bit synchronous up-counter

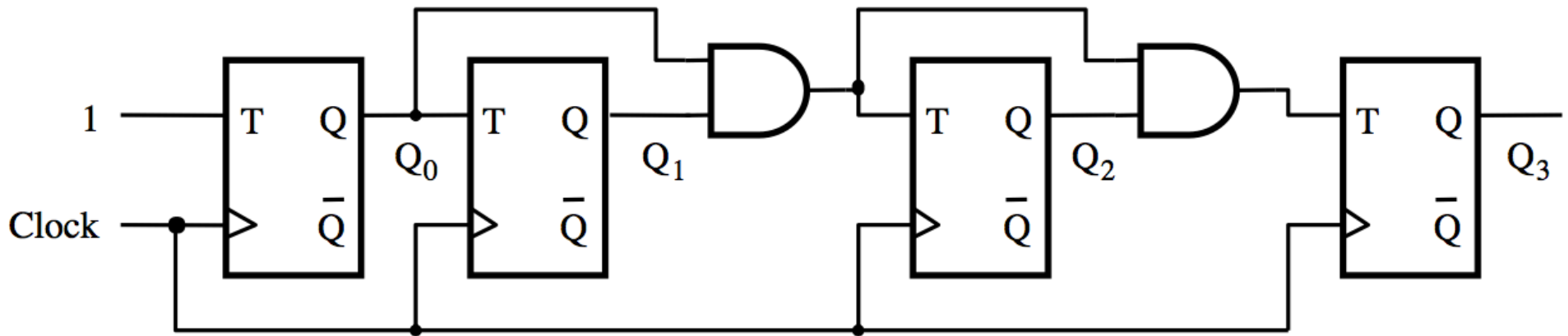

$$T_0 = 1$$

$$T_1 = Q_0$$

$$T_2 = Q_0 Q_1$$

In general we have

$$T_0 = 1$$

$$T_1 = Q_0$$

$$T_2 = Q_0 Q_1$$

$$T_3 = Q_0 Q_1 Q_2$$

...

$$T_n = Q_0 Q_1 Q_2 \cdots Q_{n-1}$$

Inclusion of Enable and Clear capability

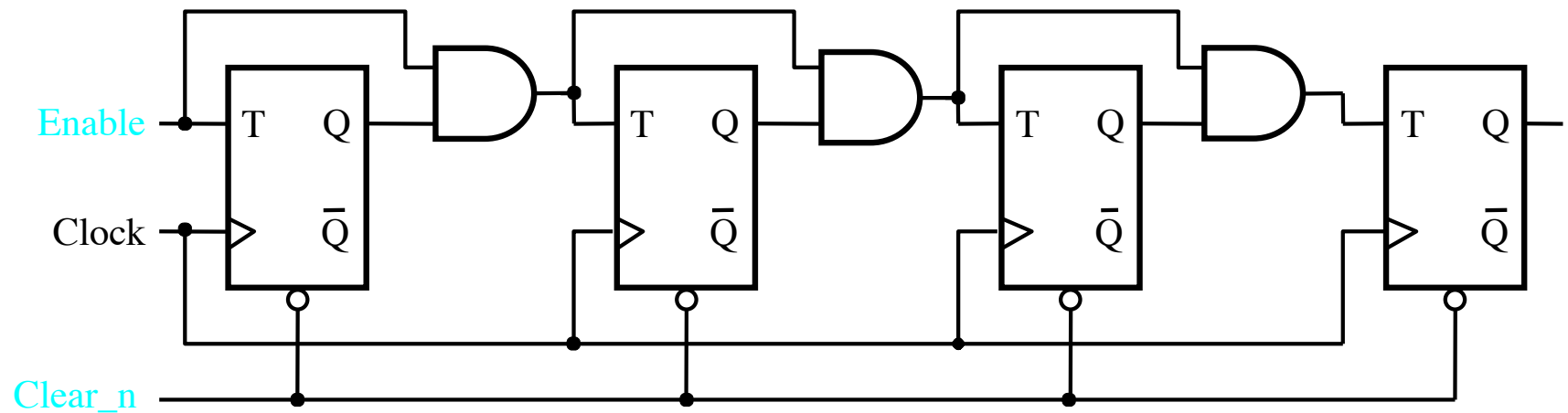

[Figure 5.22 from the textbook]

Inclusion of Enable and Clear capability

This is the new thing relative to the previous figure, plus the clear_n line

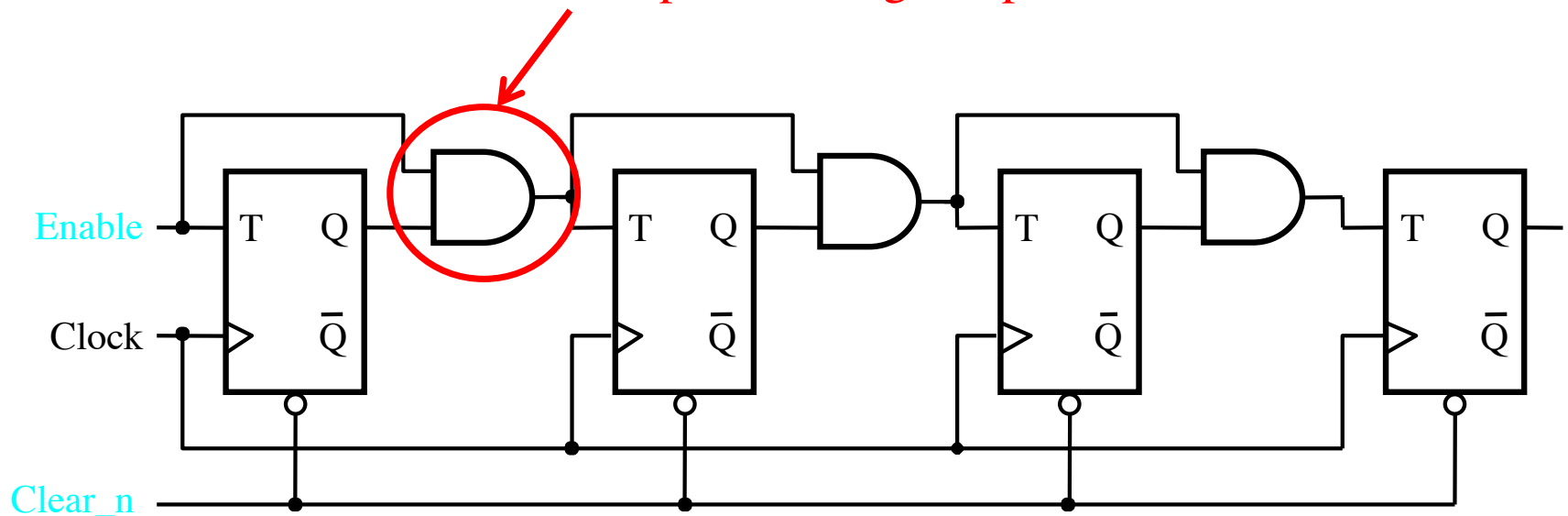

T Flip-Flop

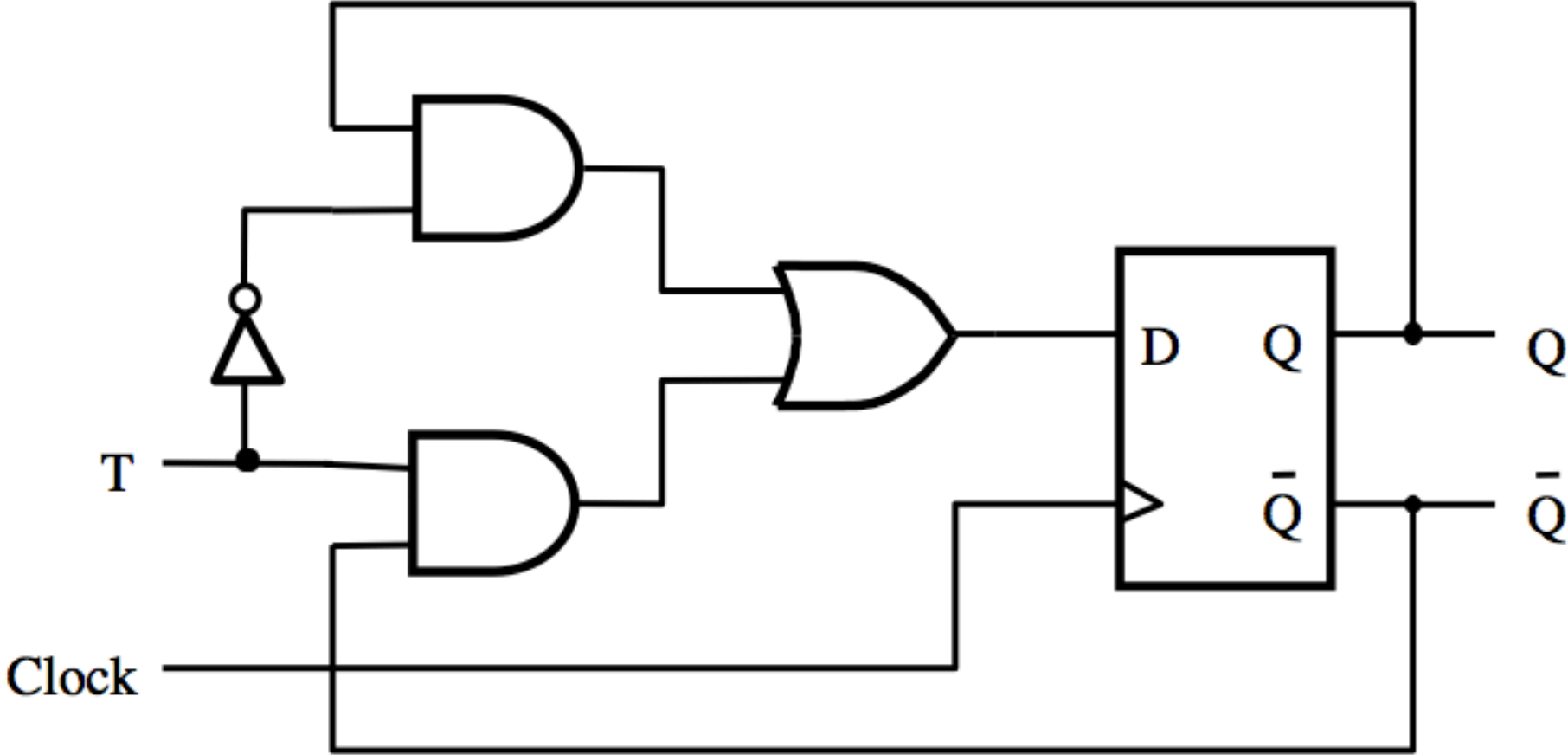

[Figure 5.15a from the textbook]

T Flip-Flop

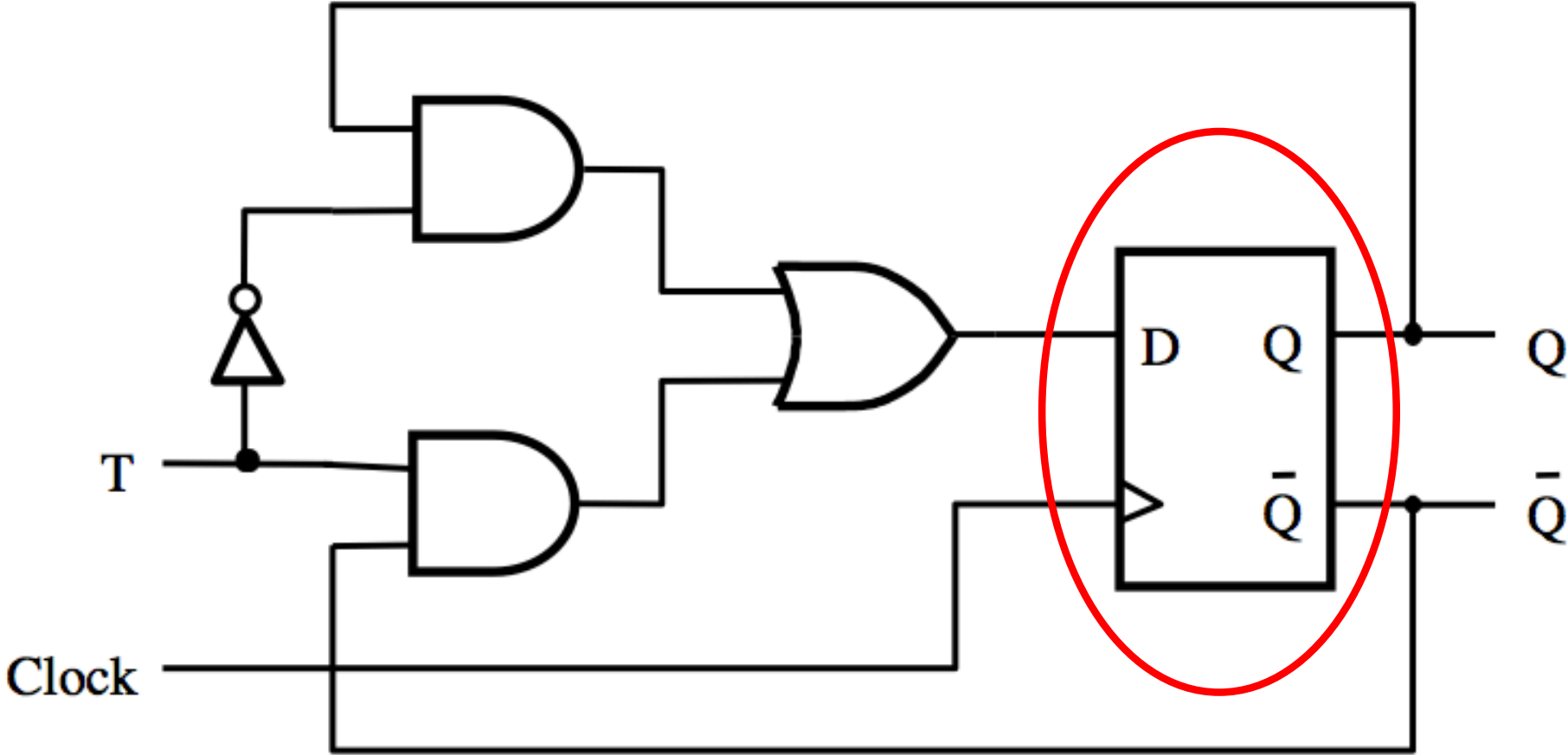

Positive-edge-triggered
D Flip-Flop

[Figure 5.15a from the textbook]

T Flip-Flop

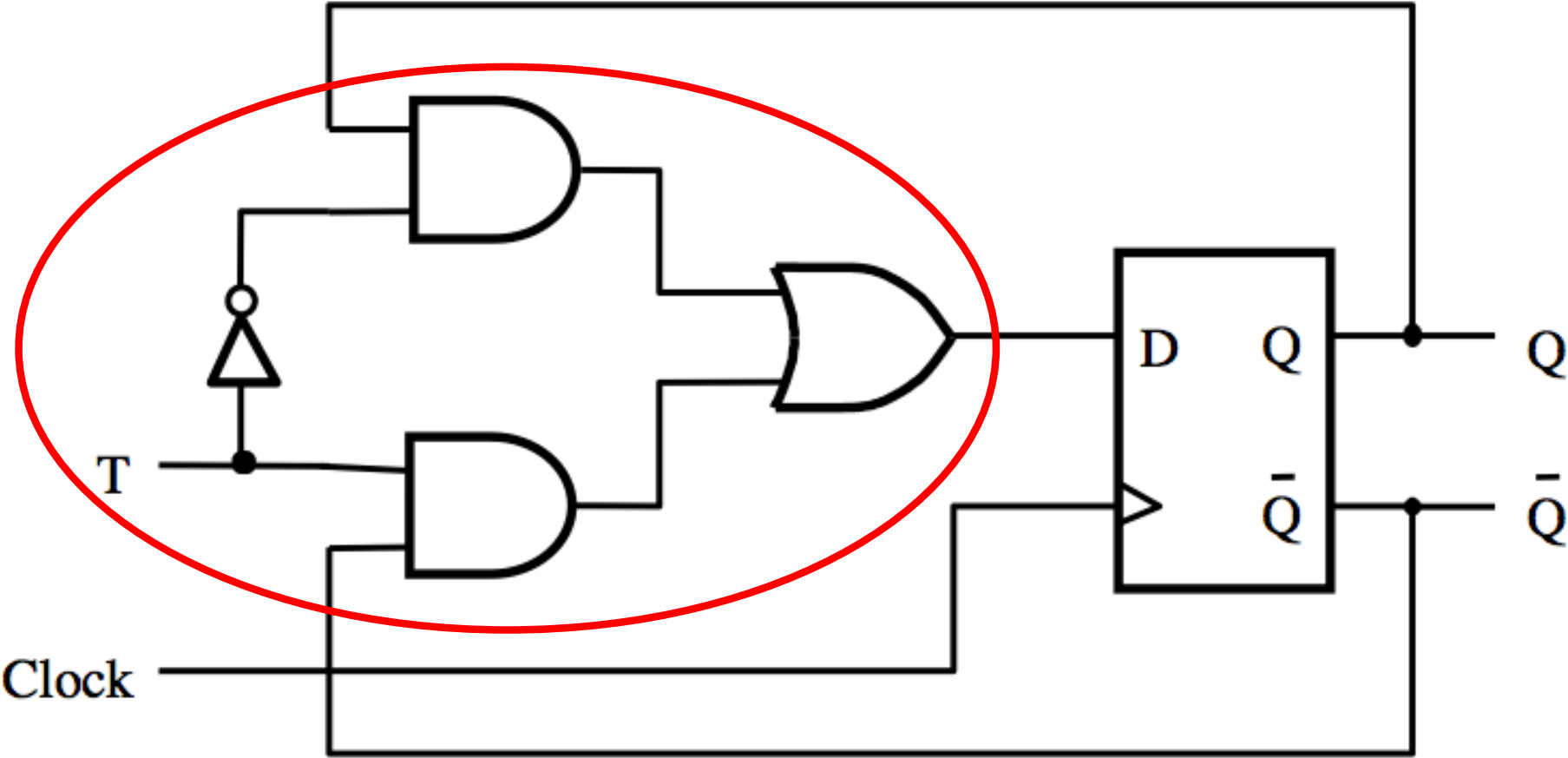

2-to-1 multiplexer

[Figure 5.15a from the textbook]

2-to-1 Multiplexer

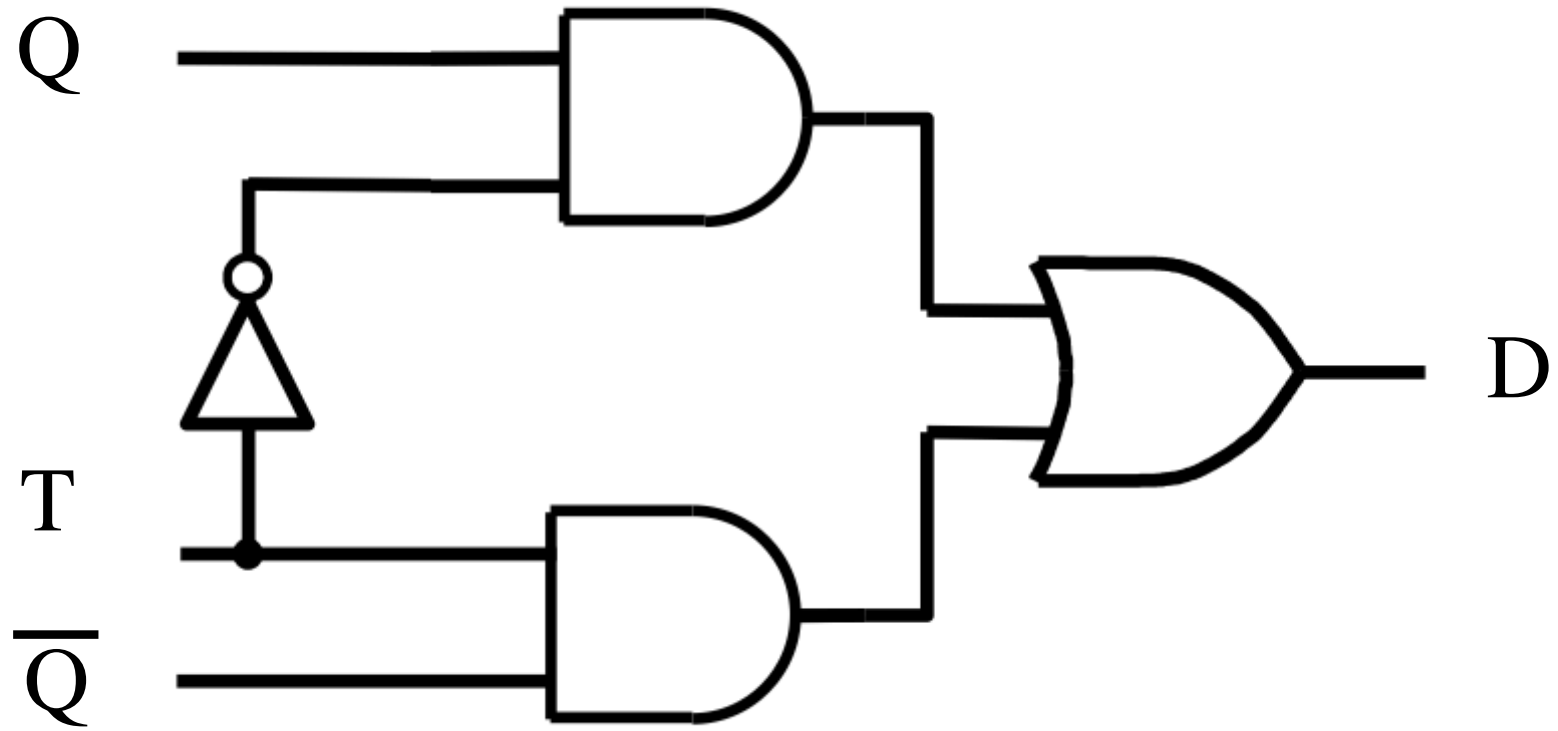

What is this?

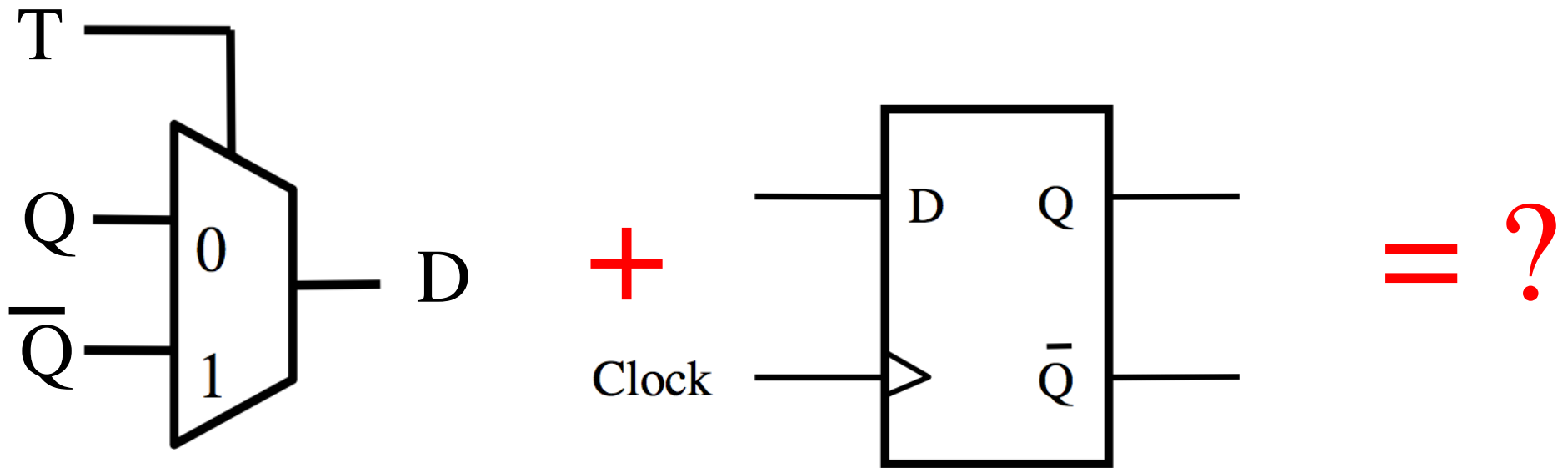

T Flip-Flop

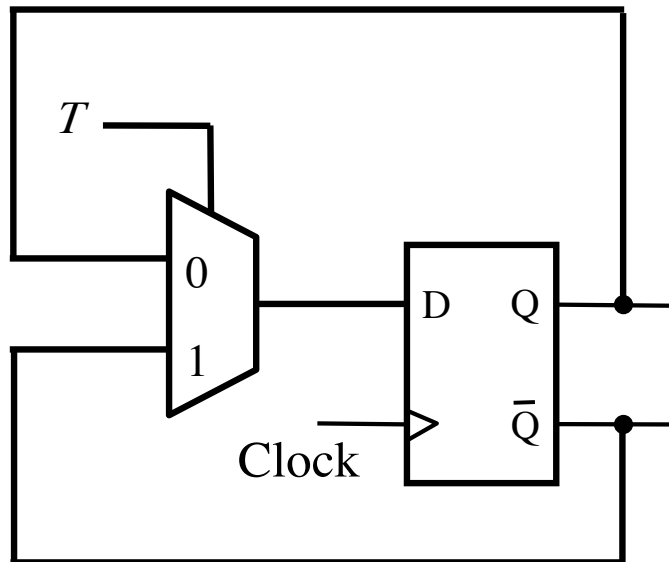

T Flip-Flop

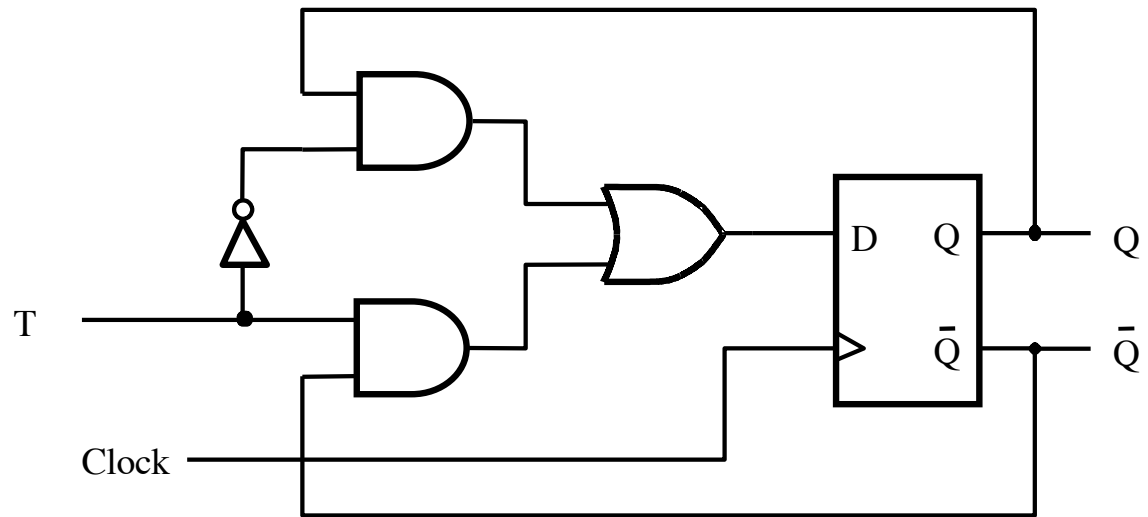

T Flip-Flop

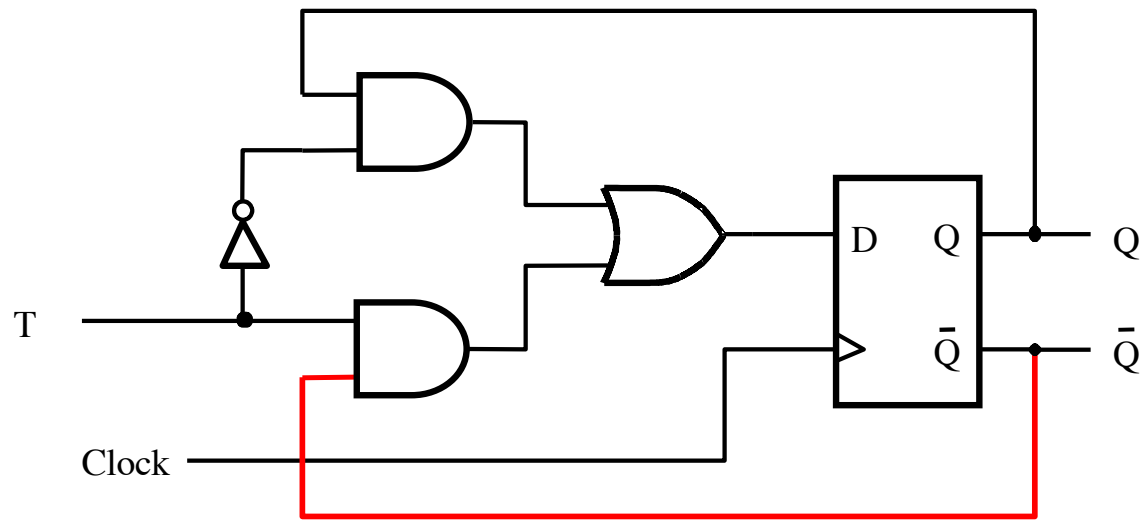

T Flip-Flop

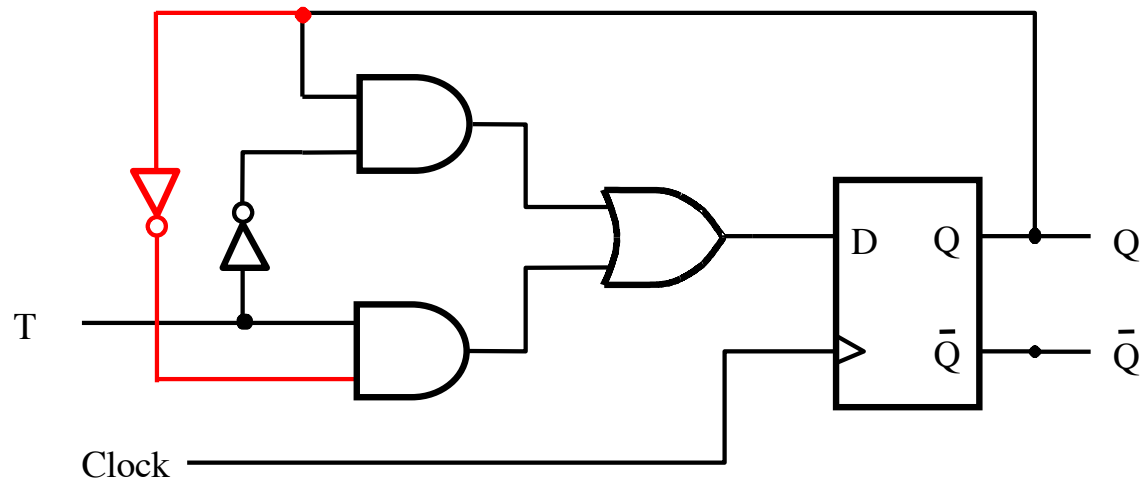

These two circuits are equivalent

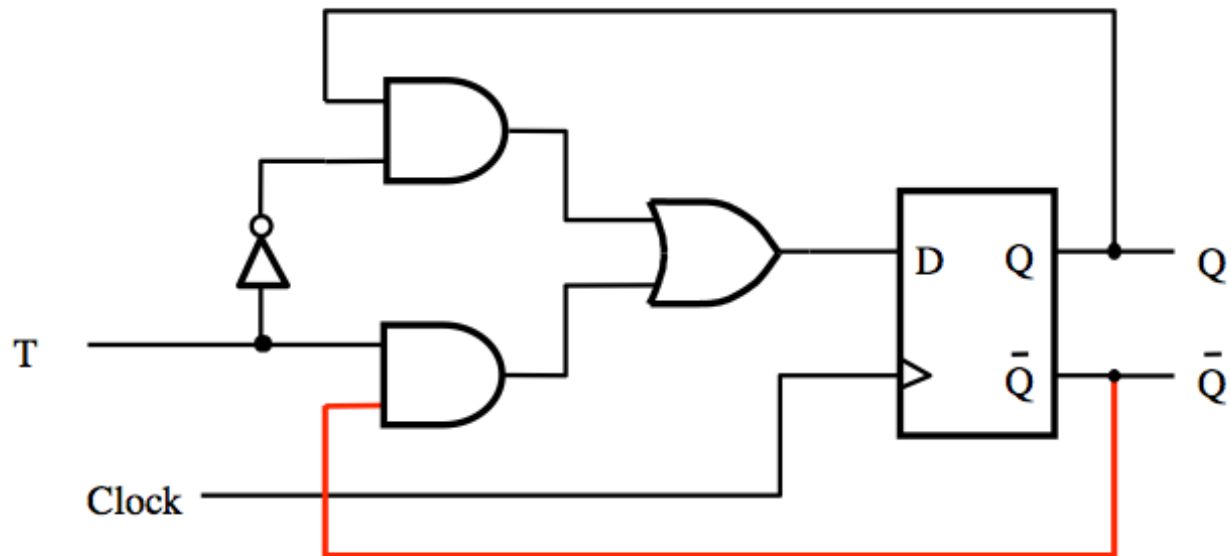
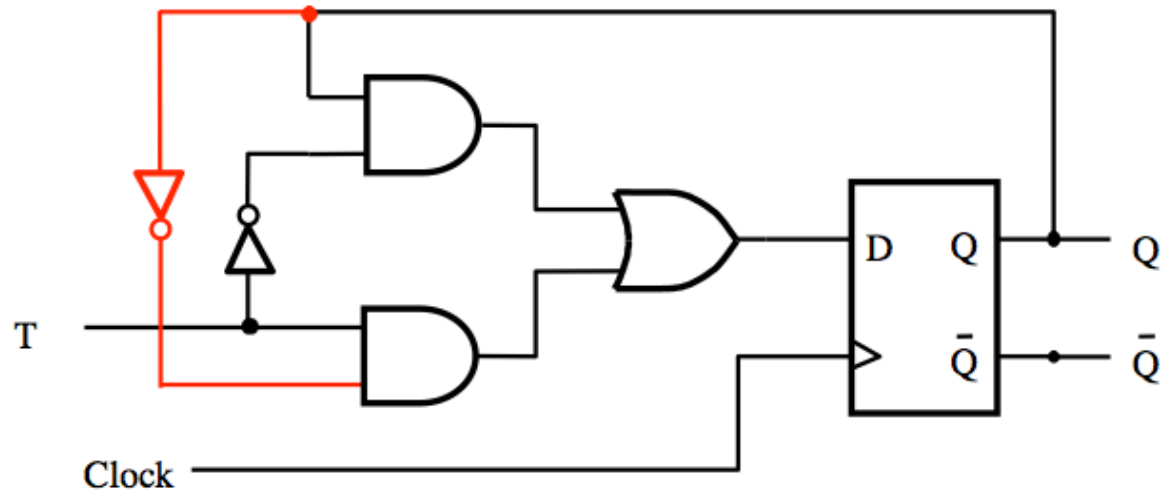

What is this?

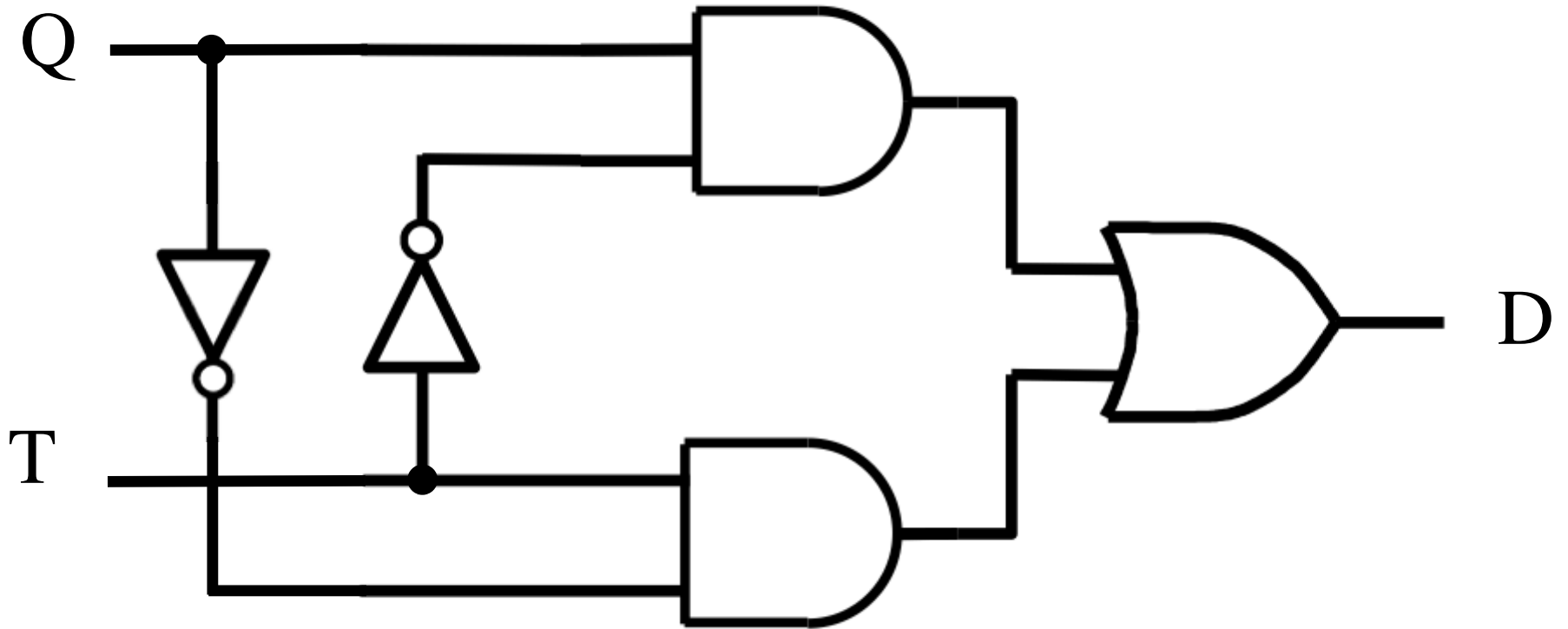

What is this?

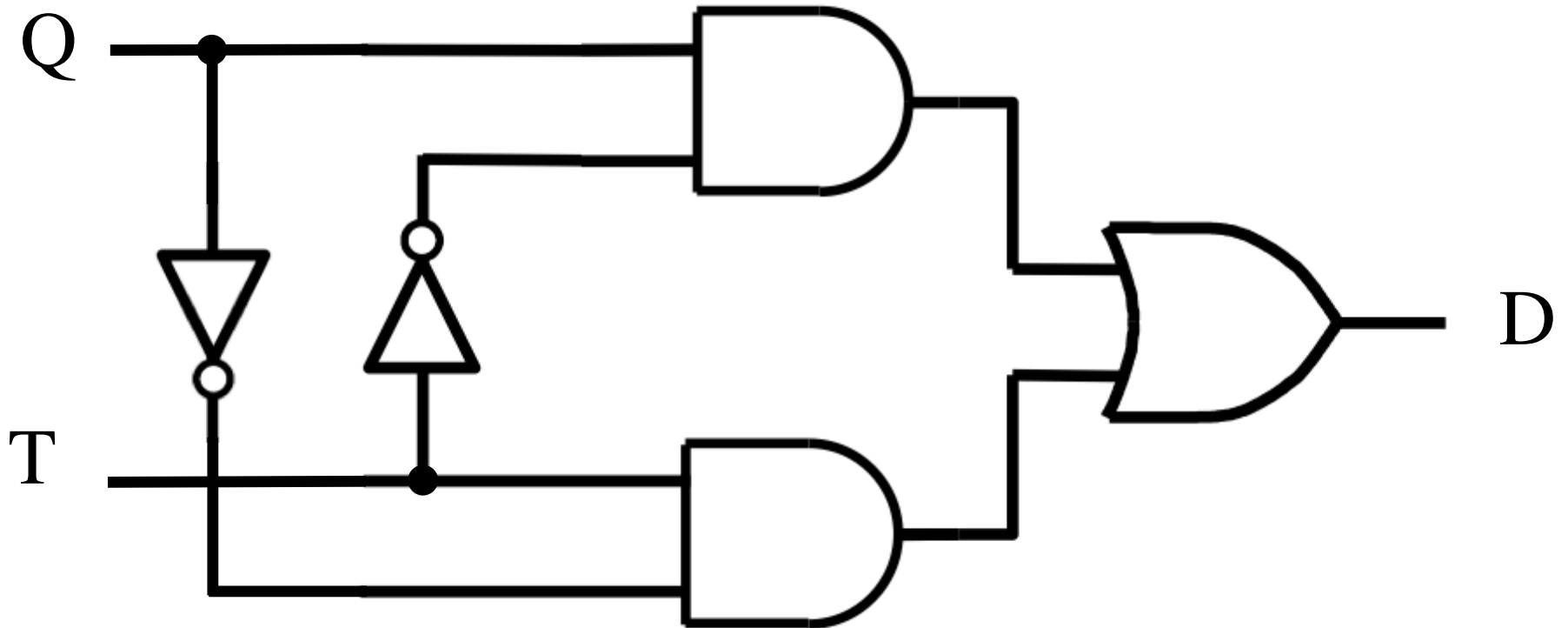

$$D = \overline{Q}T + Q\overline{T}$$

What is this?

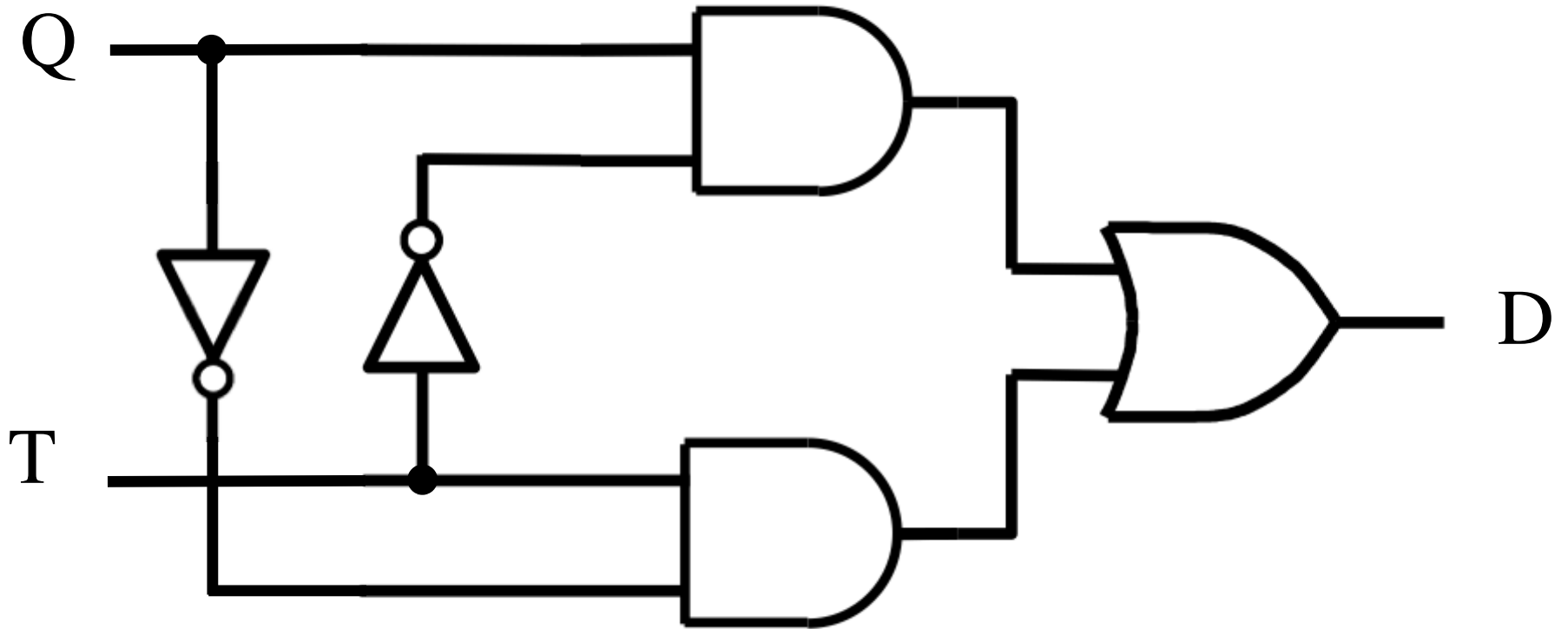

$$D = Q \oplus T$$

What is this?

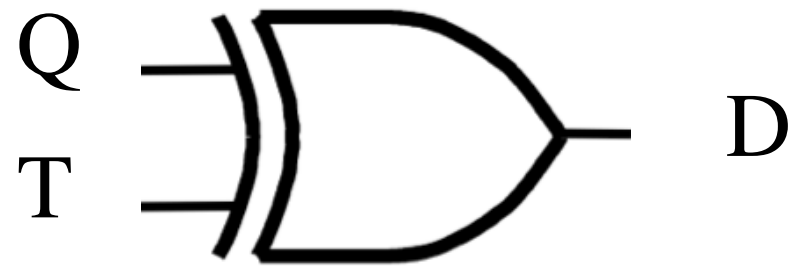

$$D = Q \oplus T$$

What is this?

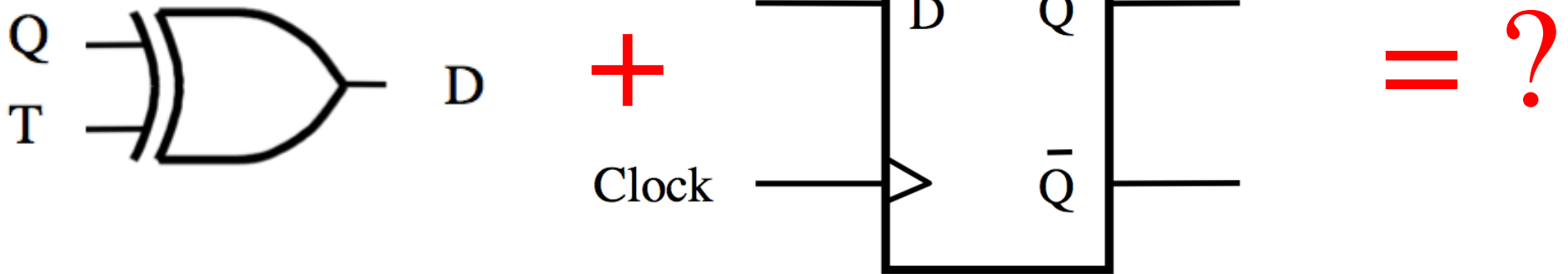

T Flip-Flop

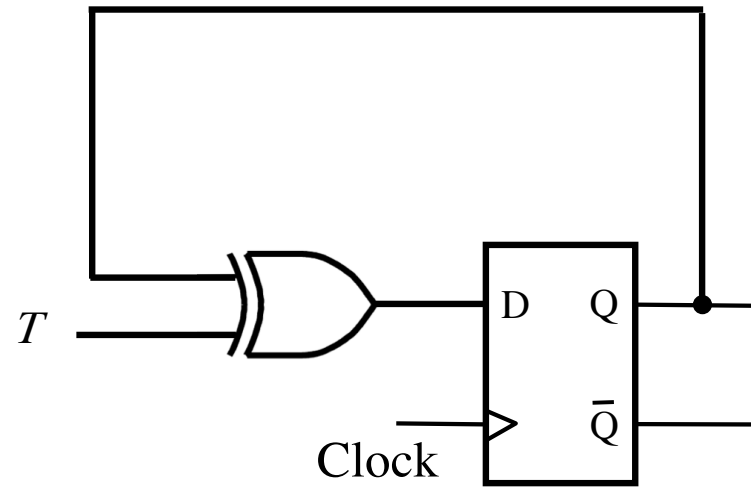

Synchronous Counter with D Flip-Flops

A three-bit up-counter with T flip-flops

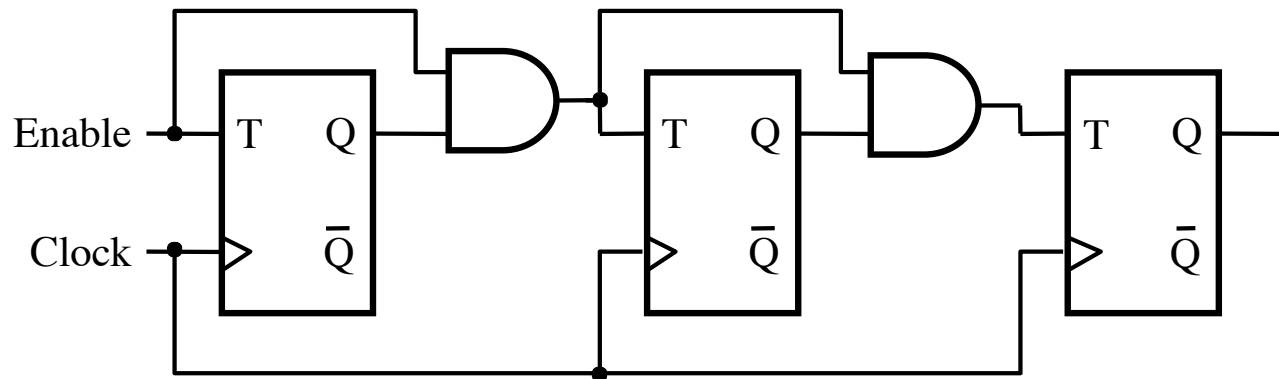

A three-bit up-counter with D flip-flops

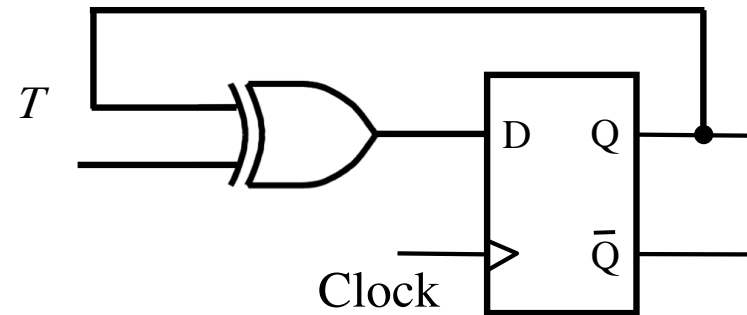
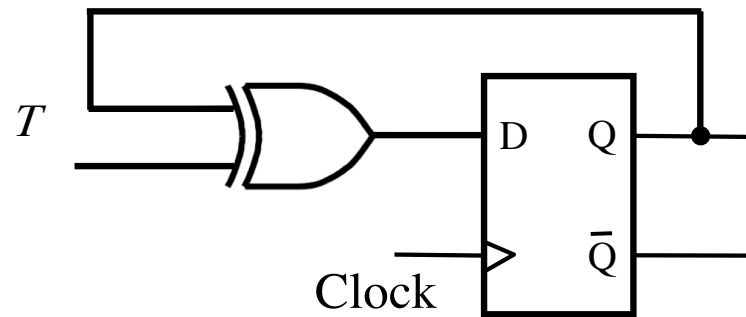
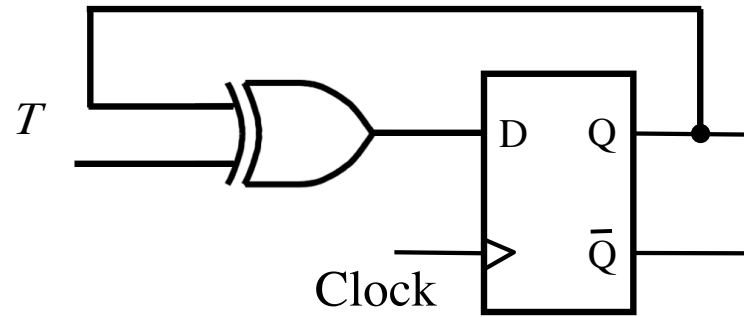

A three-bit up-counter with D flip-flops

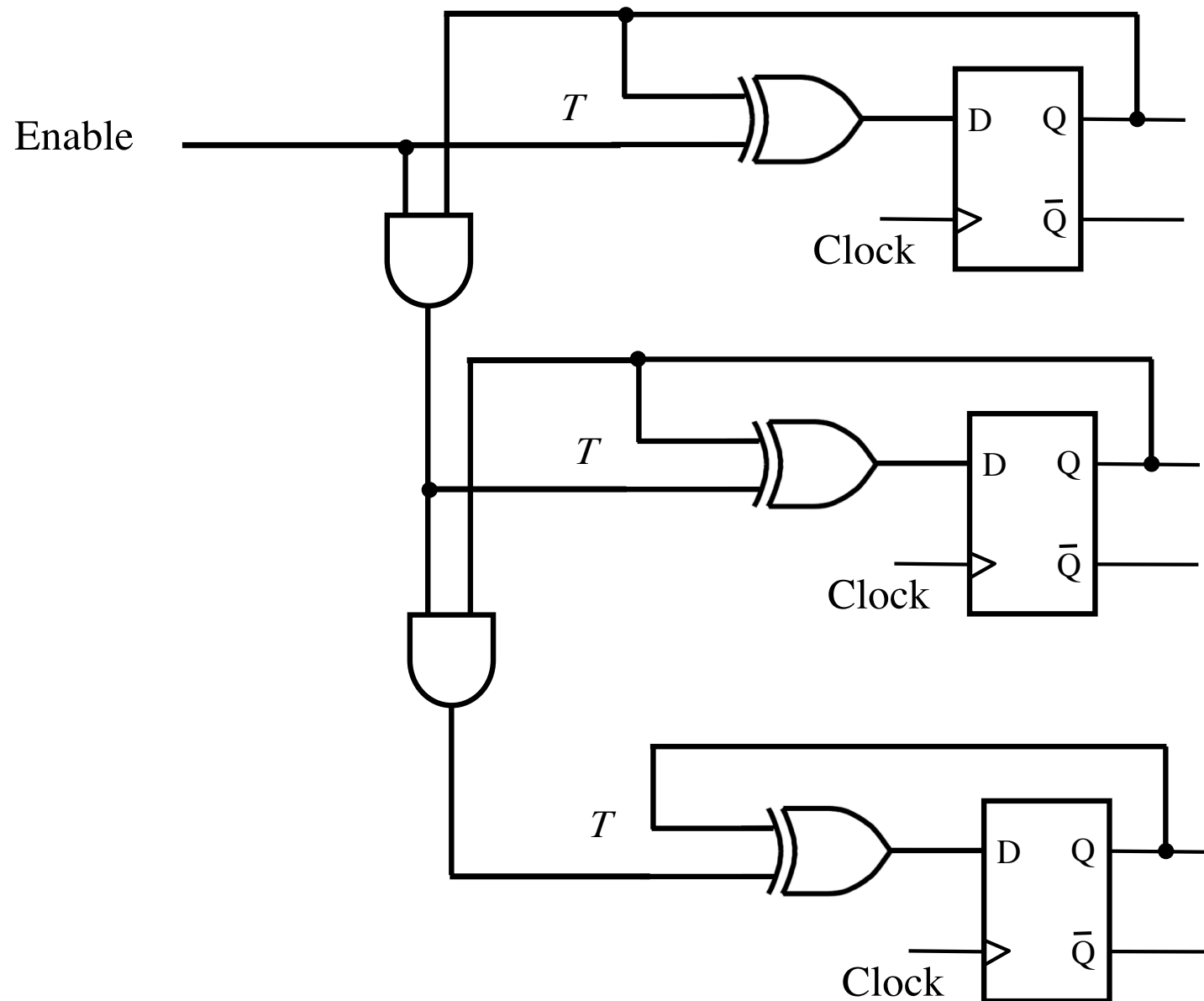

A three-bit up-counter with D flip-flops

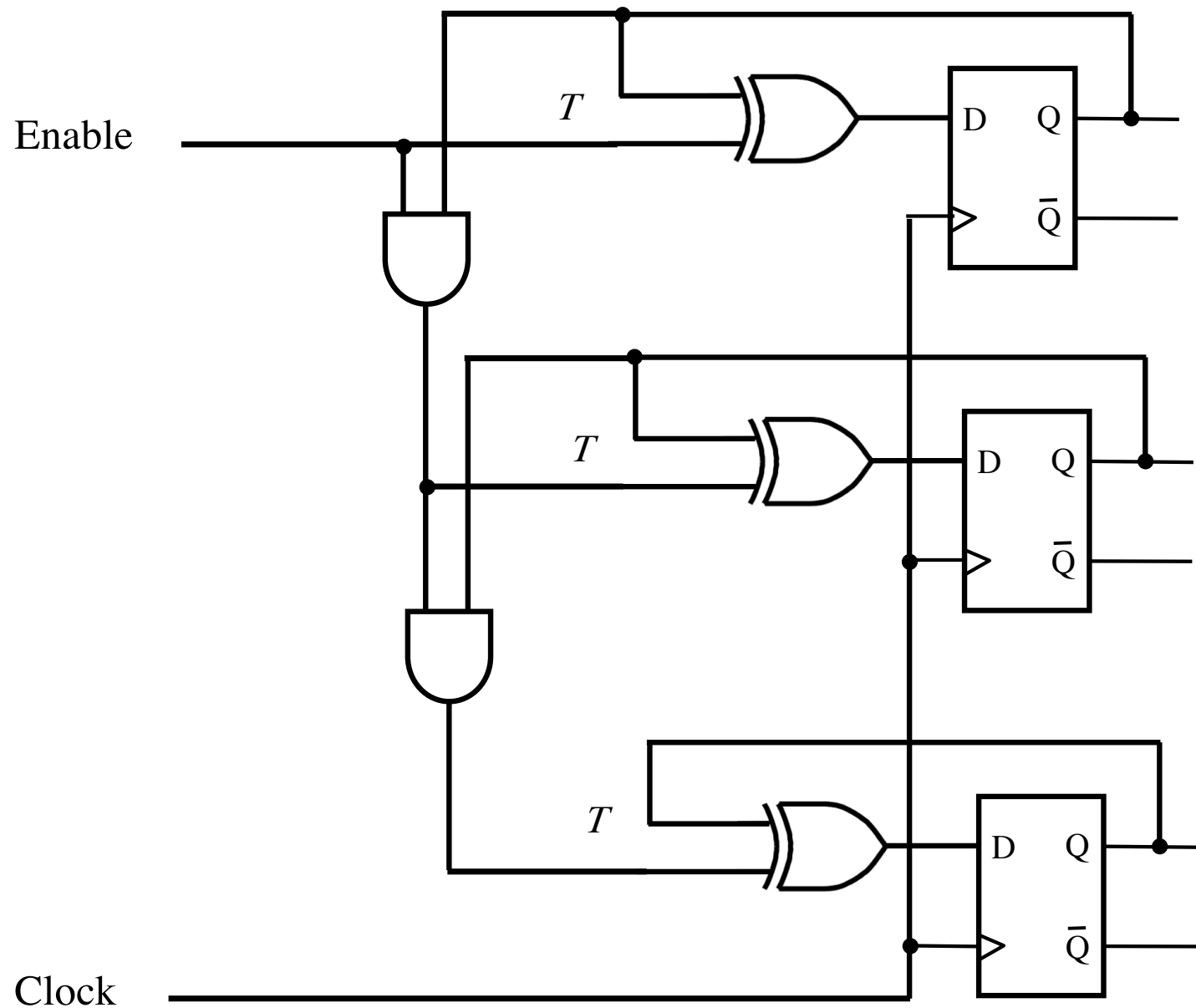

A four-bit up-counter with T flip-flops

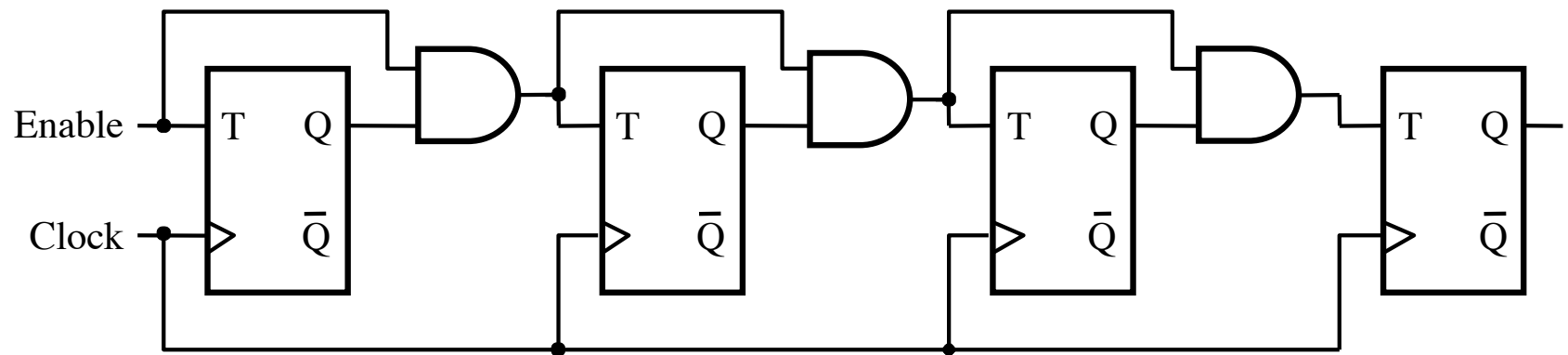

A four-bit up-counter with D flip-flops

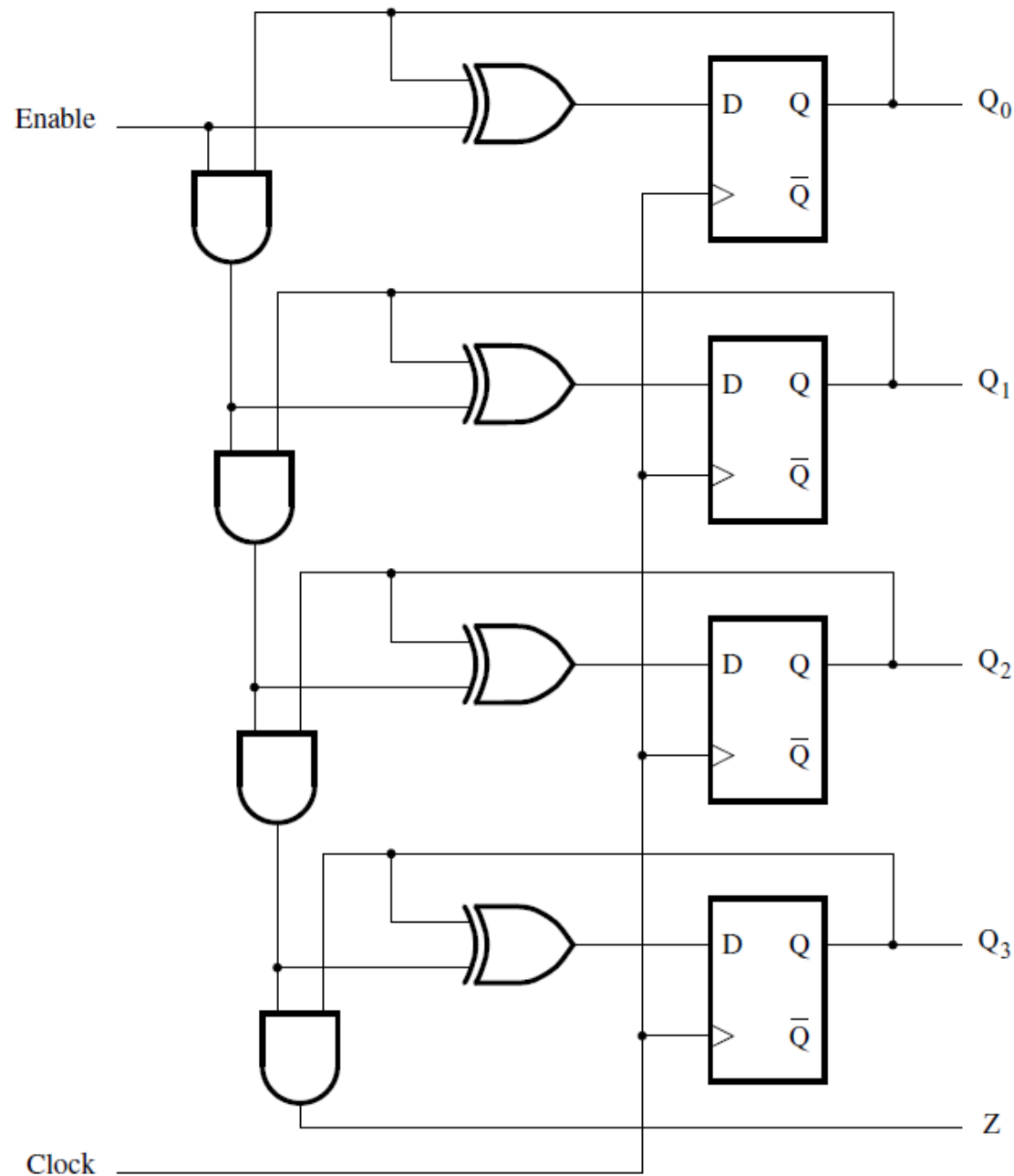

[Figure 5.23 from the textbook]

End of Mini Review

Goal

- **Implement a modulo-8 counter using the sequential circuit approach**
- **In other words, the counting sequence must be 0, 1, 2, 3, 4, 5, 6, 7, 0, 1, 2, ...**
- **The count changes based on the input signal w :**
 - **If $w=0$, then the count remains the same**
 - **If $w=1$, then the count is advanced by one**

State diagram for the counter

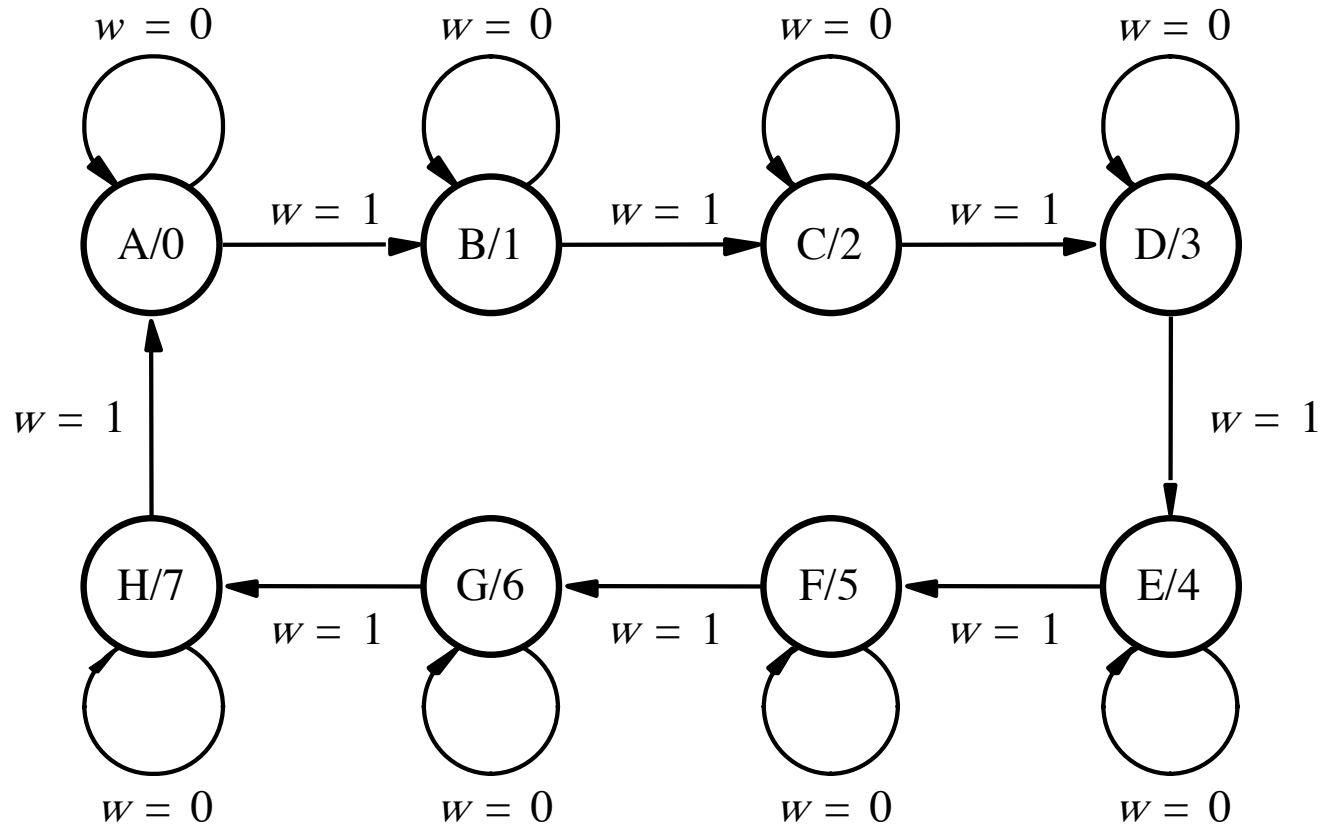

State table for the counter

Present state	Next state		Output
	$w = 0$	$w = 1$	
A	A	B	0
B	B	C	1
C	C	D	2
D	D	E	3
E	E	F	4
F	F	G	5
G	G	H	6
H	H	A	7

State-assigned table for the counter

	Present state $y_2y_1y_0$	Next state		Count $z_2z_1z_0$
		$w = 0$	$w = 1$	
		$Y_2Y_1Y_0$	$Y_2Y_1Y_0$	
A	000	000	001	000
B	001	001	010	001
C	010	010	011	010
D	011	011	100	011
E	100	100	101	100
F	101	101	110	101
G	110	110	111	110
H	111	111	000	111

K-map for Y_0

	Present state $y_2y_1y_0$	Next state		Count $z_2z_1z_0$
		$w = 0$	$w = 1$	
		$Y_2Y_1Y_0$	$Y_2Y_1Y_0$	
A	000	000	001	000
B	001	001	010	001
C	010	010	011	010
D	011	011	100	011
E	100	100	101	100
F	101	101	110	101
G	110	110	111	110
H	111	111	000	111

		y_1y_0			
	wy_2	00	01	11	10
00					
01					
11					
10					

K-map for Y_0

	Present state $y_2y_1y_0$	Next state		Count $z_2z_1z_0$
		$w = 0$	$w = 1$	
		$Y_2Y_1Y_0$	$Y_2Y_1Y_0$	
A	000	0	1	000
B	001	1	0	001
C	010	0	1	010
D	011	1	0	011
E	100	0	1	100
F	101	1	0	101
G	110	0	1	110
H	111	1	0	111

		y_1y_0			
	wy_2	00	01	11	10
00					
01					
11					
10					

K-map for Y_0

	Present state $y_2y_1y_0$	Next state		Count $z_2z_1z_0$
		$w = 0$	$w = 1$	
		$Y_2Y_1Y_0$	$Y_2Y_1Y_0$	
A	000	0	1	000
B	001	1	0	001
C	010	0	1	010
D	011	1	0	011
E	100	0	1	100
F	101	1	0	101
G	110	0	1	110
H	111	1	0	111

wy_2 \ y_1y_0	00	01	11	10
00	0	1	1	0
01	0	1	1	0
11	1	0	0	1
10	1	0	0	1

K-map for Y_0

	Present state $y_2y_1y_0$	Next state		Count $z_2z_1z_0$
		$w = 0$	$w = 1$	
		$Y_2Y_1Y_0$	$Y_2Y_1Y_0$	
A	000	0	1	000
B	001	1	0	001
C	010	0	1	010
D	011	1	0	011
E	100	0	1	100
F	101	1	0	101
G	110	0	1	110
H	111	1	0	111

$wy_2 \backslash y_1y_0$	00	01	11	10
00	0	1	1	0
01	0	1	1	0
11	1	0	0	1
10	1	0	0	1

$$Y_0 = \bar{w}y_0 + w\bar{y}_0$$

K-map for Y_1

	Present state $y_2y_1y_0$	Next state		Count $z_2z_1z_0$
		$w = 0$	$w = 1$	
		$Y_2Y_1Y_0$	$Y_2Y_1Y_0$	
A	000	000	001	000
B	001	001	010	001
C	010	010	011	010
D	011	011	100	011
E	100	100	101	100
F	101	101	110	101
G	110	110	111	110
H	111	111	000	111

wy_2 \ y_1y_0	00	01	11	10
00				
01				
11				
10				

K-map for Y_1

	Present state $y_2y_1y_0$	Next state		Count $z_2z_1z_0$
		$w = 0$	$w = 1$	
		$Y_2Y_1Y_0$	$Y_2Y_1Y_0$	
A	000	0	0	000
B	001	0	1	001
C	010	1	1	010
D	011	1	0	011
E	100	0	0	100
F	101	0	1	101
G	110	1	1	110
H	111	1	0	111

		y_1y_0			
	wy_2	00	01	11	10
00					
01					
11					
10					

K-map for Y_1

	Present state $y_2y_1y_0$	Next state		Count $z_2z_1z_0$
		$w = 0$	$w = 1$	
		$Y_2Y_1Y_0$	$Y_2Y_1Y_0$	
A	000	0	0	000
B	001	0	1	001
C	010	1	1	010
D	011	1	0	011
E	100	0	0	100
F	101	0	1	101
G	110	1	1	110
H	111	1	0	111

wy_2 \ y_1y_0	00	01	11	10
00	0	0	1	1
01	0	0	1	1
11	0	1	0	1
10	0	1	0	1

K-map for Y_1

	Present state $y_2y_1y_0$	Next state		Count $z_2z_1z_0$
		$w = 0$	$w = 1$	
		$Y_2Y_1Y_0$	$Y_2Y_1Y_0$	
A	000	0	0	000
B	001	0	1	001
C	010	1	1	010
D	011	1	0	011
E	100	0	0	100
F	101	0	1	101
G	110	1	1	110
H	111	1	0	111

		y_1y_0			
		00	01	11	10
wy_2	00	0	0	1	1
	01	0	0	1	1
	11	0	1	0	1
	10	0	1	0	1

$$Y_1 = \bar{w}y_1 + y_1\bar{y}_0 + wy_0\bar{y}_1$$

K-map for Y_2

	Present state $y_2y_1y_0$	Next state		Count $z_2z_1z_0$
		$w = 0$	$w = 1$	
		$Y_2Y_1Y_0$	$Y_2Y_1Y_0$	
A	000	000	001	000
B	001	001	010	001
C	010	010	011	010
D	011	011	100	011
E	100	100	101	100
F	101	101	110	101
G	110	110	111	110
H	111	111	000	111

		y_1y_0			
		00	01	11	10
wy_2	00				
	01				
	11				
	10				

K-map for Y_2

	Present state $y_2y_1y_0$	Next state		Count $z_2z_1z_0$
		$w = 0$	$w = 1$	
		$Y_2Y_1Y_0$	$Y_2Y_1Y_0$	
A	000	0	0	000
B	001	0	0	001
C	010	0	0	010
D	011	0	1	011
E	100	1	1	100
F	101	1	1	101
G	110	1	1	110
H	111	1	0	111

	y_1y_0	00	01	11	10
wy_2	00				
	01				
	11				
	10				

K-map for Y_2

	Present state $y_2y_1y_0$	Next state		Count $z_2z_1z_0$
		$w = 0$	$w = 1$	
		$Y_2Y_1Y_0$	$Y_2Y_1Y_0$	
A	000	0	0	000
B	001	0	0	001
C	010	0	0	010
D	011	0	1	011
E	100	1	1	100
F	101	1	1	101
G	110	1	1	110
H	111	1	0	111

wy_2 \ y_1y_0	00	01	11	10
00	0	0	0	0
01	1	1	1	1
11	1	1	0	1
10	0	0	1	0

K-map for Y_2

	Present state $y_2y_1y_0$	Next state		Count $z_2z_1z_0$
		$w = 0$	$w = 1$	
		$Y_2Y_1Y_0$	$Y_2Y_1Y_0$	
A	000	0	0	000
B	001	0	0	001
C	010	0	0	010
D	011	0	1	011
E	100	1	1	100
F	101	1	1	101
G	110	1	1	110
H	111	1	0	111

	y_1y_0	00	01	11	10
wy_2	00	0	0	0	0
	01	1	1	1	1
	11	1	1	0	1
	10	0	0	1	0

$$Y_2 = \bar{w}y_2 + \bar{y}_0y_2 + \bar{y}_1y_2 + wy_0y_1\bar{y}_2$$

Karnaugh maps for D flip-flops for the counter

		y_1y_0			
		00	01	11	10
wy_2	00	0	1	1	0
	01	0	1	1	0
	11	1	0	0	1
	10	1	0	0	1

$$Y_0 = \bar{w}y_0 + wy_0$$

		y_1y_0			
		00	01	11	10
wy_2	00	0	0	1	1
	01	0	0	1	1
	11	0	1	0	1
	10	0	1	0	1

$$Y_1 = \bar{w}y_1 + y_1\bar{y}_0 + wy_0\bar{y}_1$$

		y_1y_0			
		00	01	11	10
wy_2	00	0	0	0	0
	01	1	1	1	1
	11	1	1	0	1
	10	0	0	1	0

$$Y_2 = \bar{w}y_2 + \bar{y}_0y_2 + \bar{y}_1y_2 + wy_0y_1\bar{y}_2$$

Circuit diagram
for the counter
implemented
with D flip-flops

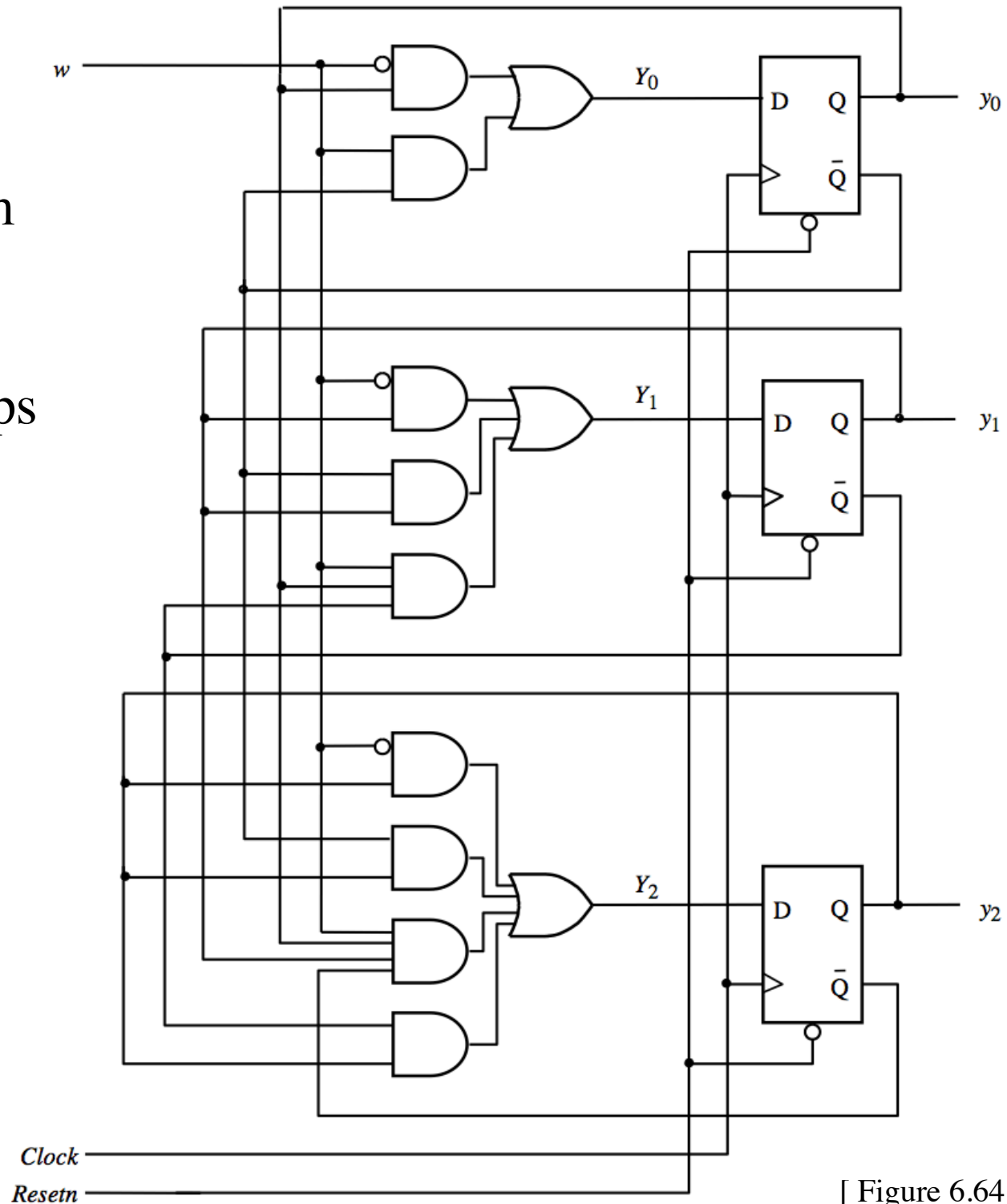

[Figure 6.64 from the textbook]

Circuit diagram
for the counter
implemented
with D flip-flops

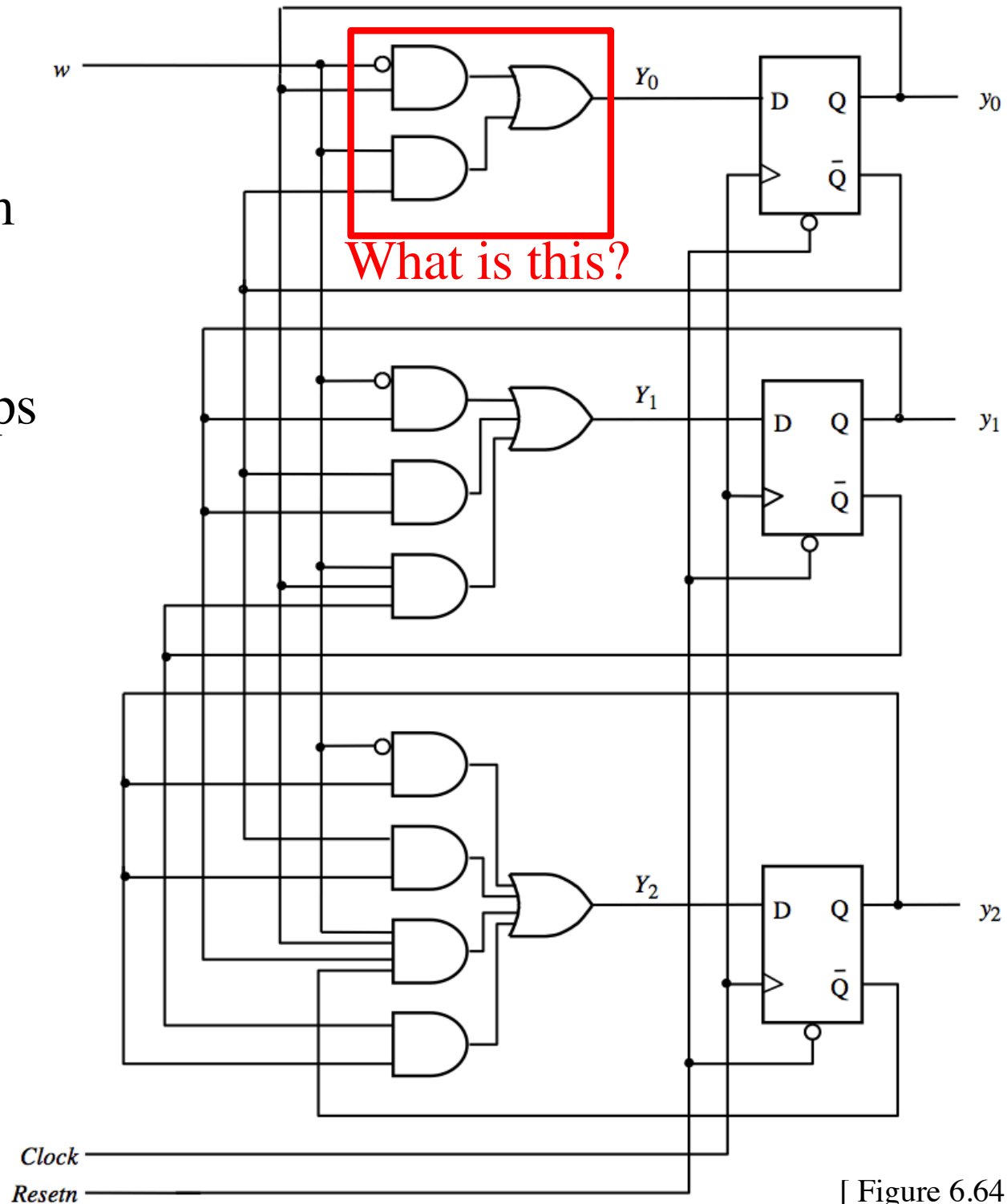

[Figure 6.64 from the textbook]

Circuit diagram
for the counter
implemented
with D flip-flops

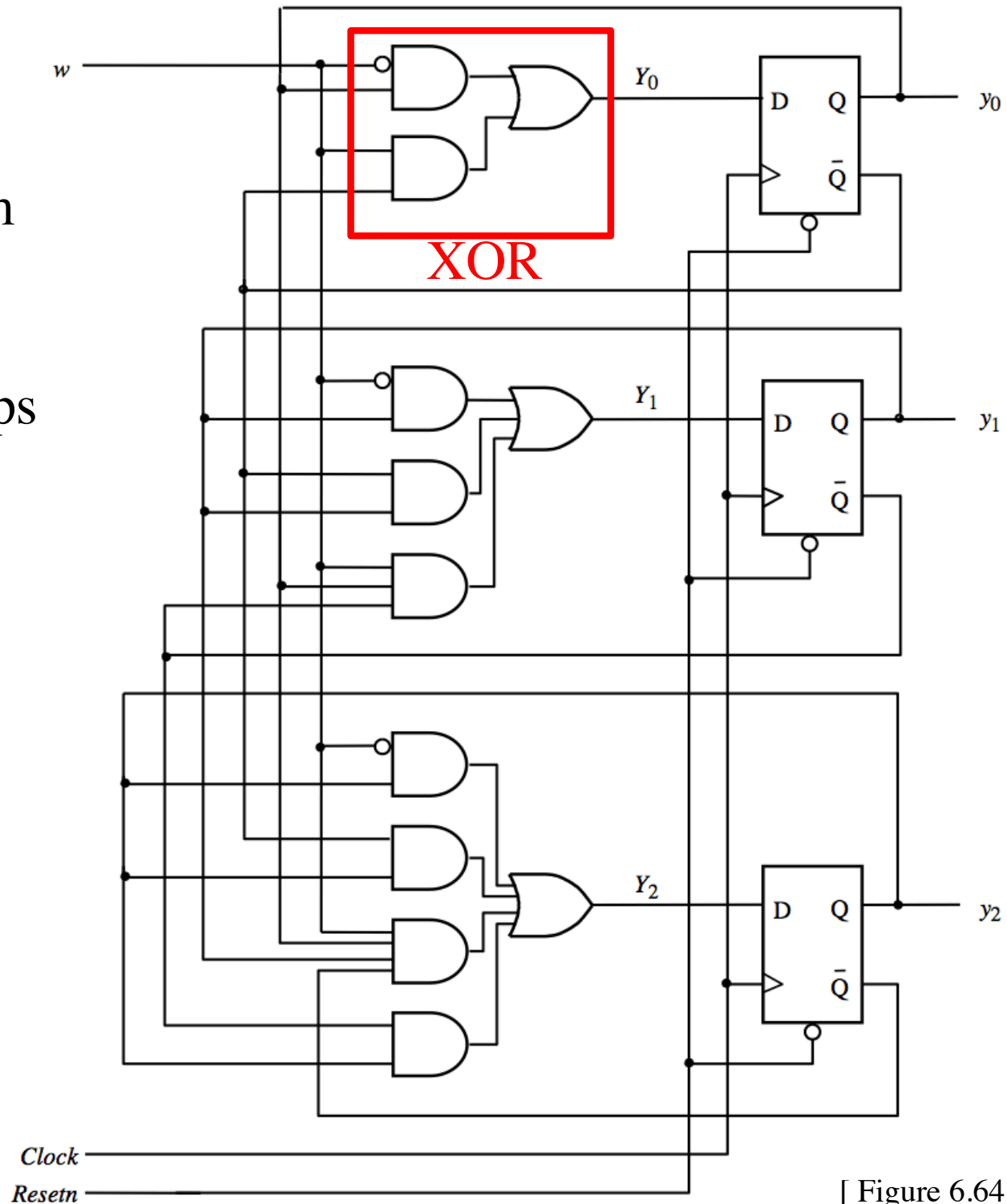

[Figure 6.64 from the textbook]

We can simplify all three expressions

$$Y_0 = \bar{w}y_0 + wy_0\bar{y}_0$$

$$Y_1 = \bar{w}y_1 + y_1\bar{y}_0 + wy_0\bar{y}_1$$

$$Y_2 = \bar{w}y_2 + \bar{y}_0y_2 + \bar{y}_1y_2 + wy_0y_1\bar{y}_2$$

We can simplify all three expressions

$$Y_0 = \bar{w}y_0 + w\bar{y}_0$$

$$\begin{aligned} D_0 &= \bar{w}y_0 + w\bar{y}_0 \\ &= w \oplus y_0 \end{aligned}$$

$$Y_1 = \bar{w}y_1 + y_1\bar{y}_0 + wy_0\bar{y}_1$$

$$\begin{aligned} D_1 &= \bar{w}y_1 + y_1\bar{y}_0 + wy_0\bar{y}_1 \\ &= (\bar{w} + \bar{y}_0)y_1 + wy_0\bar{y}_1 \\ &= \bar{w}\bar{y}_0y_1 + wy_0\bar{y}_1 \\ &= wy_0 \oplus y_1 \end{aligned}$$

$$Y_2 = \bar{w}y_2 + \bar{y}_0y_2 + \bar{y}_1y_2 + wy_0y_1\bar{y}_2$$

$$\begin{aligned} D_2 &= \bar{w}y_2 + \bar{y}_0y_2 + \bar{y}_1y_2 + wy_0y_1\bar{y}_2 \\ &= (\bar{w} + \bar{y}_0 + \bar{y}_1)y_2 + wy_0y_1\bar{y}_2 \\ &= \bar{w}\bar{y}_0\bar{y}_1y_2 + wy_0y_1\bar{y}_2 \\ &= wy_0y_1 \oplus y_2 \end{aligned}$$

A three-bit counter with D flip-flops

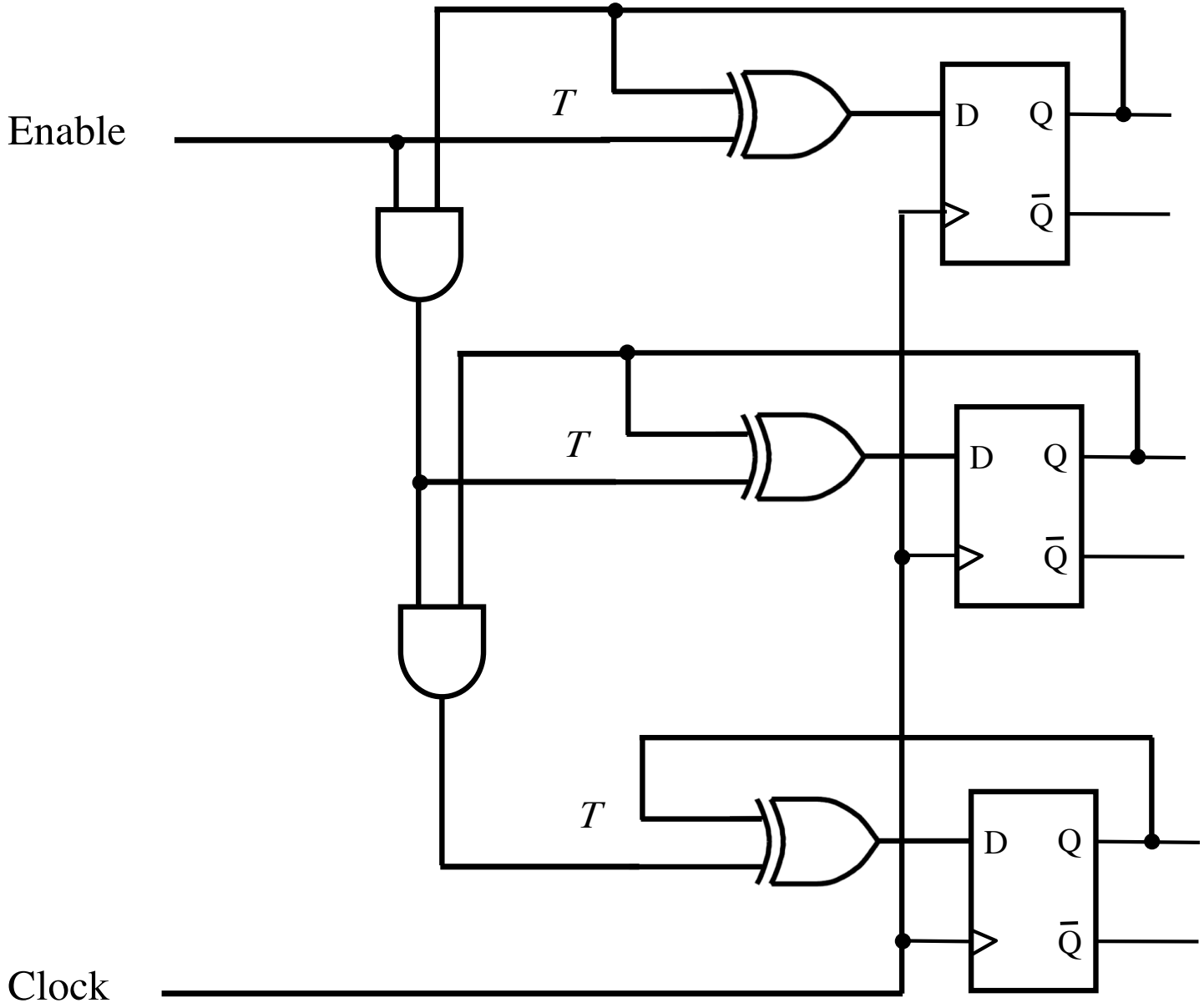

A four-bit counter with D flip-flops

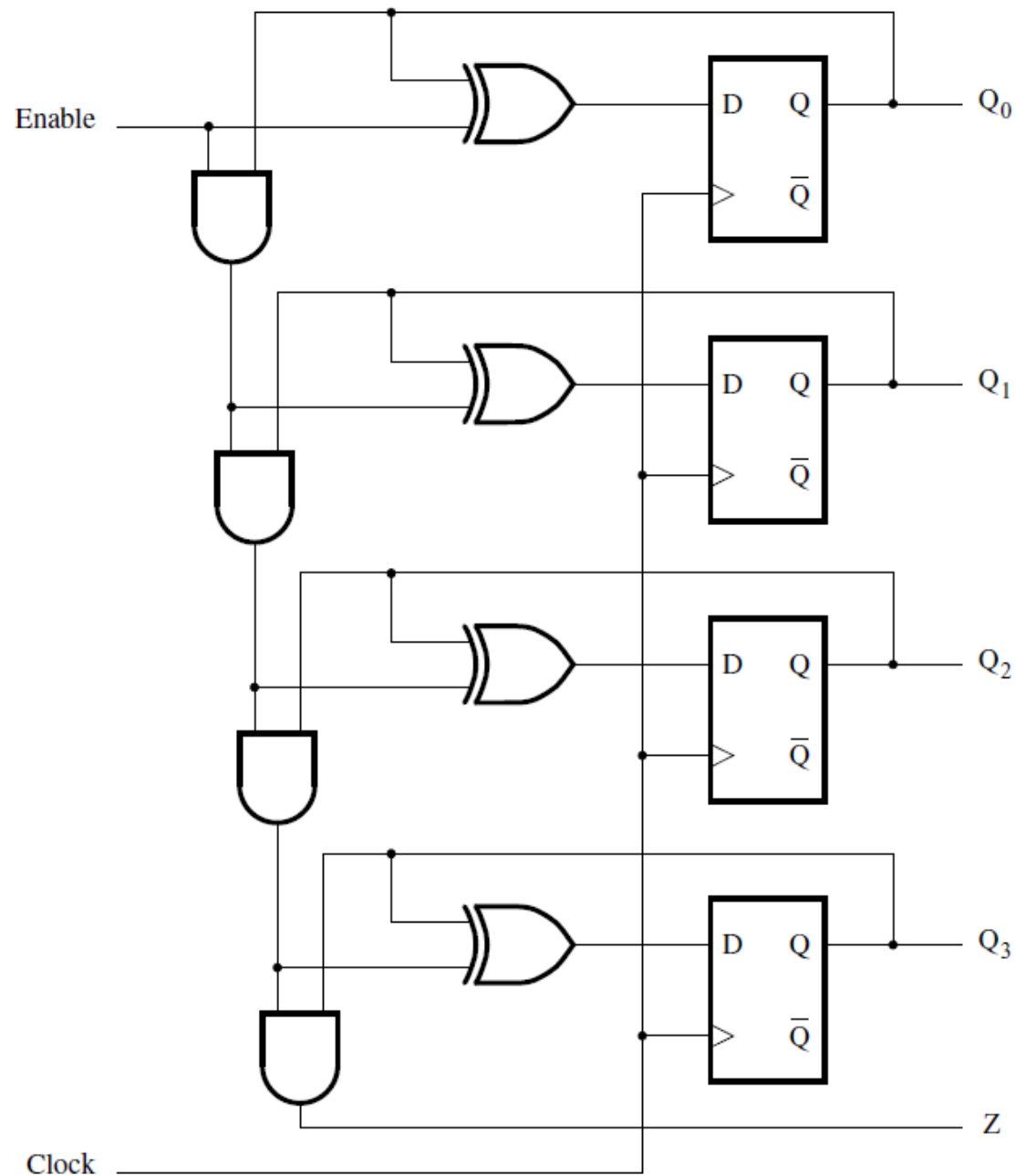

[Figure 5.23 from the textbook]

Summary

- **The up-counters that we studied in Chapter 5 can now be derived using the sequential circuit approach**
- **We get the same circuit diagrams as before**

**Example 2:
Implement a modulo-8 counter
using JK Flip-Flops**

JK Flip-Flop

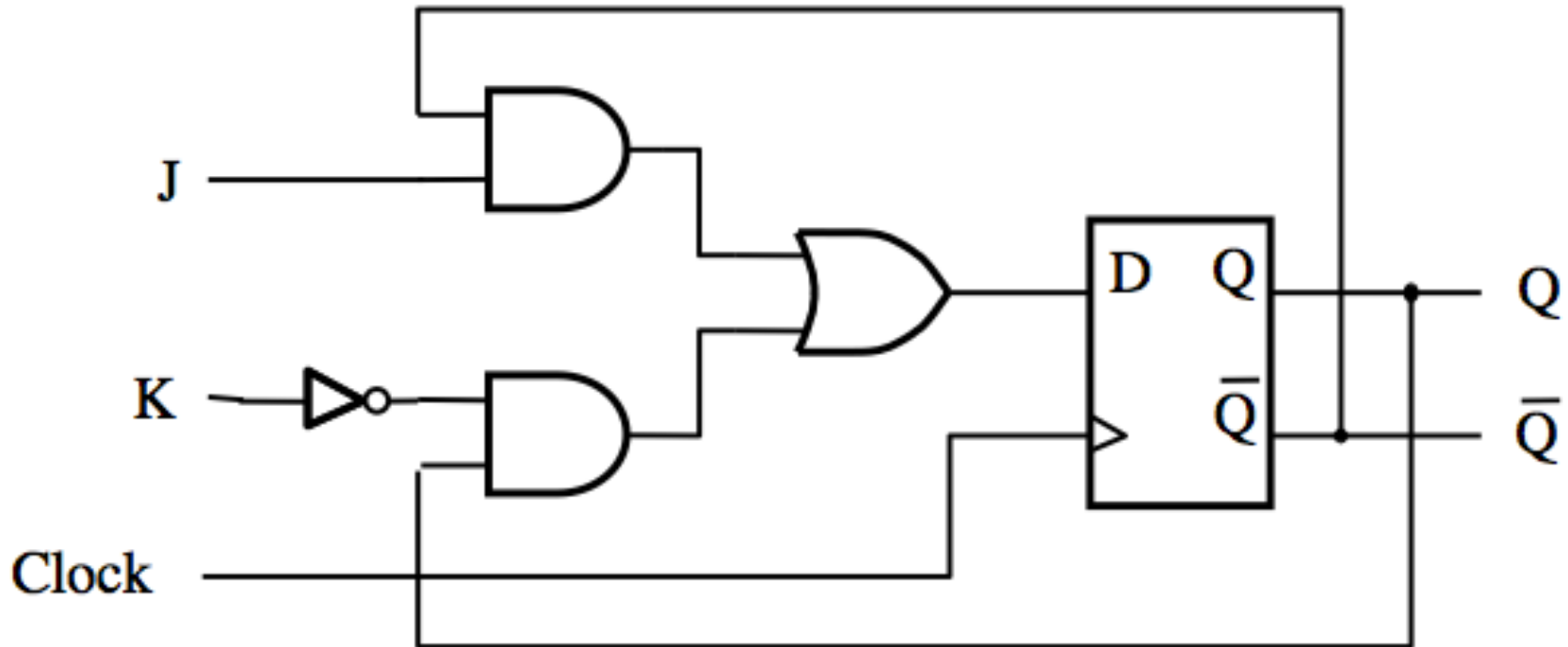

$$D = \overline{J}Q + \overline{K}Q$$

JK Flip-Flop

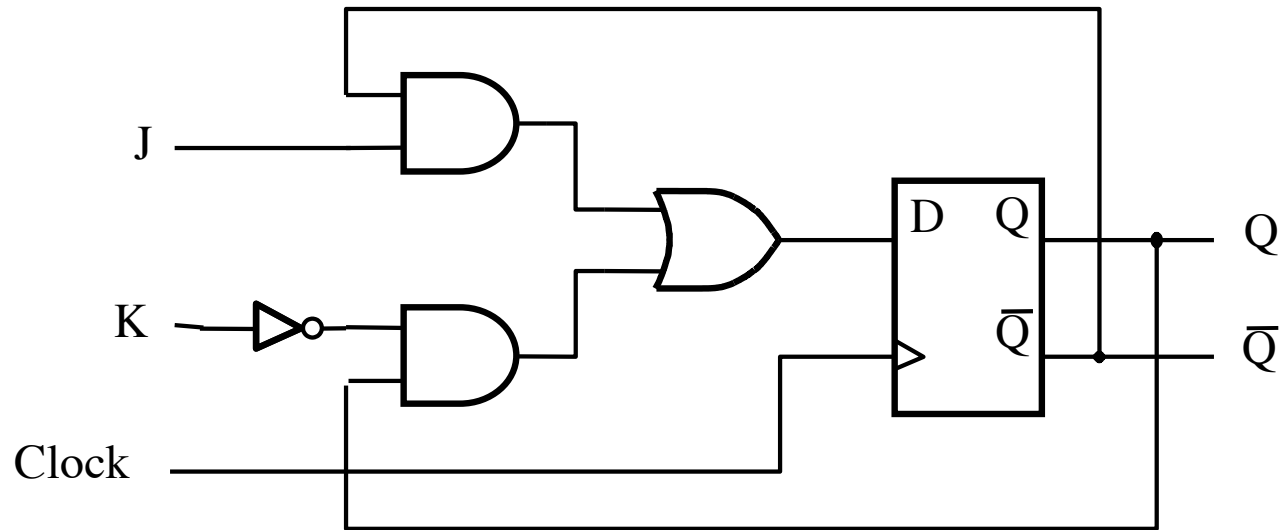

(a) Circuit

J	K	$Q(t+1)$
0	0	$Q(t)$
0	1	0
1	0	1
1	1	$\bar{Q}(t)$

(b) Truth table

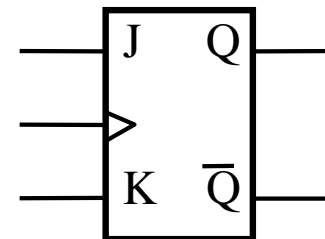

(c) Graphical symbol

JK Flip-Flop (How it Works)

**A versatile circuit that can be used both as a
SR flip-flop and as a T flip flop**

If $J=0$ and $K=0$ it stays in the same state

Just like SR It can be set and reset

$J=S$ and $K=R$

If $J=K$ then it behaves as a T flip-flop

If $J=K$ then it behaves as a T flip-flop

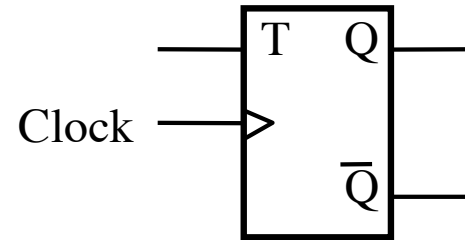
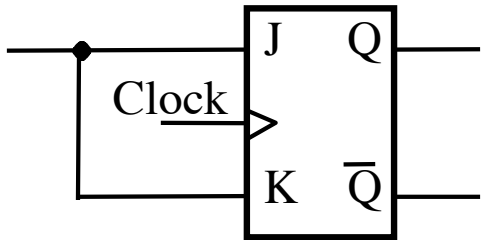

These two are equivalent

Transition Rules in terms of J and K

Current State
of the Flip-flop: $Q(t)$

Next State
of the Flip-flop: $Q(t+1)$

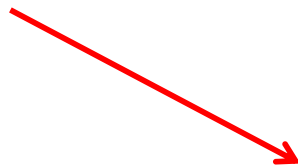

- From 0 to 0 $J=0$ and $K=d$
- From 0 to 1 $J=1$ and $K=d$
- From 1 to 0 $J=d$ and $K=1$
- From 1 to 1 $J=d$ and $K=0$

J	K	$Q(t+1)$
0	0	$Q(t)$
0	1	0
1	0	1
1	1	$\bar{Q}(t)$

Transition Rules in terms of J and K

Current State
of the Flip-flop: $Q(t)$

Next State
of the Flip-flop: $Q(t+1)$

- From 0 to 0 $J=0$ and $K=d$
- From 0 to 1 $J=1$ and $K=d$
- From 1 to 0 $J=d$ and $K=1$
- From 1 to 1 $J=d$ and $K=0$

J	K	$Q(t+1)$
0	0	$Q(t)$
0	1	0
1	0	1
1	1	$\bar{Q}(t)$

$Q(t) \rightarrow Q(t+1)$	J	K
$0 \rightarrow 0$	0	d
$0 \rightarrow 1$	1	d
$1 \rightarrow 0$	d	1
$1 \rightarrow 1$	d	0

Excitation table for the counter with JK flip-flops

	Present state $y_2y_1y_0$	Flip-flop inputs								Count $z_2z_1z_0$
		$w = 0$				$w = 1$				
		$Y_2Y_1Y_0$	J_2K_2	J_1K_1	J_0K_0	$Y_2Y_1Y_0$	J_2K_2	J_1K_1	J_0K_0	
A	000	000	0d	0d	0d	001	0d	0d	1d	000
B	001	001	0d	0d	d0	010	0d	1d	d1	001
C	010	010	0d	d0	0d	011	0d	d0	1d	010
D	011	011	0d	d0	d0	100	1d	d1	d1	011
E	100	100	d0	0d	0d	101	d0	0d	1d	100
F	101	101	d0	0d	d0	110	d0	1d	d1	101
G	110	110	d0	d0	0d	111	d0	d0	1d	110
H	111	111	d0	d0	d0	000	d1	d1	d1	111

Excitation table for the counter with JK flip-flops

	Present state $y_2y_1y_0$	Flip-flop inputs								Count $z_2z_1z_0$
		$w = 0$				$w = 1$				
		$Y_2Y_1Y_0$	J_2K_2	J_1K_1	J_0K_0	$Y_2Y_1Y_0$	J_2K_2	J_1K_1	J_0K_0	
A	000	000	0d	0d	0d	001	0d	0d	1d	000
B	001	001	0d	0d	d0	010	0d	1d	d1	001
C	010	010	0d	d0	0d	011	0d	d0	1d	010
D	011	011	0d	d0	d0	100	1d	d1	d1	011
E	100	100	d0	0d	0d	101	d0	0d	1d	100
F	101	101	d0	0d	d0	110	d0	1d	d1	101
G	110	110	d0	d0	0d	111	d0	d0	1d	110
H	111	111	d0	d0	d0	000	d1	d1	d1	111

$Q(t) \rightarrow Q(t+1)$	J K
0 → 0	0 d
0 → 1	1 d
1 → 0	d 1
1 → 1	d 0

[Figure 6.65 from the textbook]

Karnaugh maps for the first JK flip-flop

	Present state $y_2y_1y_0$	Flip-flop inputs								Count $z_2z_1z_0$
		$w = 0$				$w = 1$				
		$Y_2Y_1Y_0$	J_2K_2	J_1K_1	J_0K_0	$Y_2Y_1Y_0$	J_2K_2	J_1K_1	J_0K_0	
A	000	000	0d	0d	0d	001	0d	0d	1d	000
B	001	001	0d	0d	d0	010	0d	1d	d1	001
C	010	010	0d	d0	0d	011	0d	d0	1d	010
D	011	011	0d	d0	d0	100	1d	d1	d1	011
E	100	100	d0	0d	0d	101	d0	0d	1d	100
F	101	101	d0	0d	d0	110	d0	1d	d1	101
G	110	110	d0	d0	0d	111	d0	d0	1d	110
H	111	111	d0	d0	d0	000	d1	d1	d1	111

Karnaugh map for $w = 0$:

		y_1y_0			
		00	01	11	10
wy_2	00				
	01				
	11				
	10				

Karnaugh map for $w = 1$:

		y_1y_0			
		00	01	11	10
wy_2	00				
	01				
	11				
	10				

Karnaugh maps for the first JK flip-flop

	Present state $y_2y_1y_0$	Flip-flop inputs							Count $z_2z_1z_0$	
		$w = 0$				$w = 1$				
		$Y_2Y_1Y_0$	J_2K_2	J_1K_1	J_0K_0	$Y_2Y_1Y_0$	J_2K_2	J_1K_1		J_0K_0
A	000	000	0d	0d	0d	001	0d	0d	1d	000
B	001	001	0d	0d	d0	010	0d	1d	d1	001
C	010	010	0d	d0	0d	011	0d	d0	1d	010
D	011	011	0d	d0	d0	100	1d	d1	d1	011
E	100	100	d0	0d	0d	101	d0	0d	1d	100
F	101	101	d0	0d	d0	110	d0	1d	d1	101
G	110	110	d0	d0	0d	111	d0	d0	1d	110
H	111	111	d0	d0	d0	000	d1	d1	d1	111

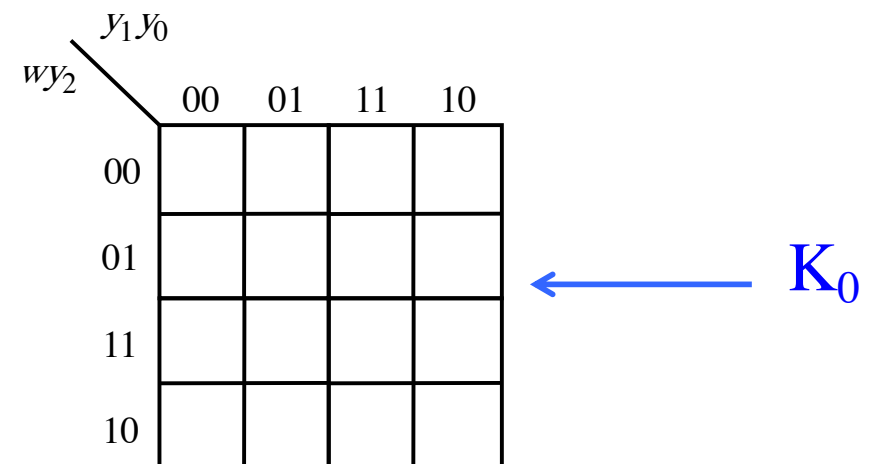
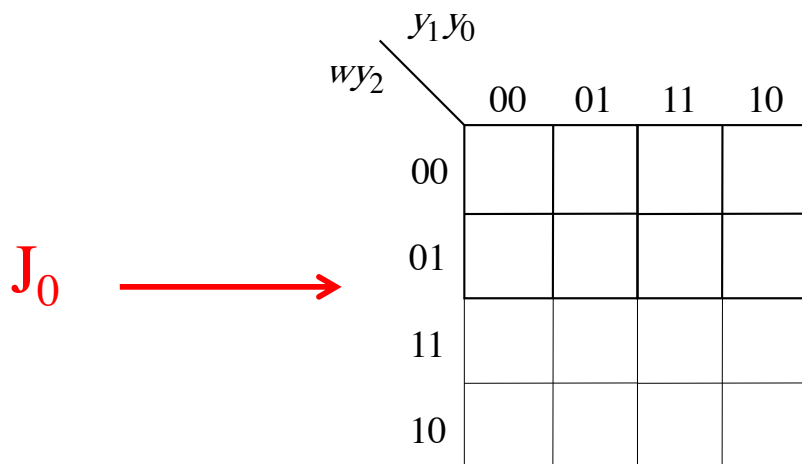

Karnaugh maps for the first JK flip-flop

	Present state $y_2y_1y_0$	Flip-flop inputs								Count $z_2z_1z_0$
		$w = 0$				$w = 1$				
		$Y_2Y_1Y_0$	J_2K_2	J_1K_1	J_0K_0	$Y_2Y_1Y_0$	J_2K_2	J_1K_1	J_0K_0	
A	000	000	0d	0d	0d	001	0d	0d	1d	000
B	001	001	0d	0d	d0	010	0d	1d	d1	001
C	010	010	0d	d0	0d	011	0d	d0	1d	010
D	011	011	0d	d0	d0	100	1d	d1	d1	011
E	100	100	d0	0d	0d	101	d0	0d	1d	100
F	101	101	d0	0d	d0	110	d0	1d	d1	101
G	110	110	d0	d0	0d	111	d0	d0	1d	110
H	111	111	d0	d0	d0	000	d1	d1	d1	111

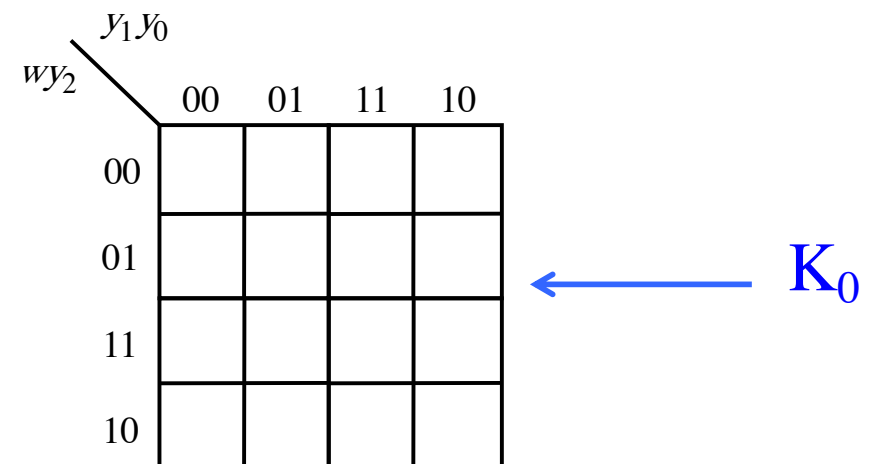
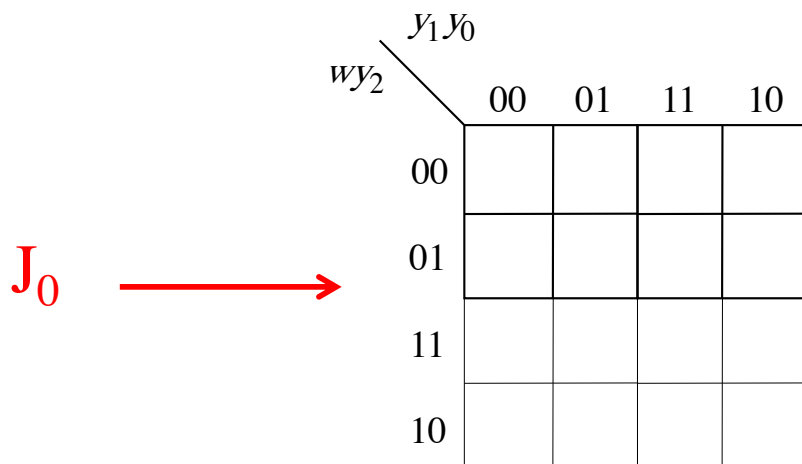

Karnaugh maps for the first JK flip-flop

	Present state $y_2y_1y_0$	Flip-flop inputs							Count $z_2z_1z_0$	
		$w = 0$				$w = 1$				
		$Y_2Y_1Y_0$	J_2K_2	J_1K_1	J_0K_0	$Y_2Y_1Y_0$	J_2K_2	J_1K_1		J_0K_0
A	000	000	0d	0d	0d	001	0d	0d	1d	000
B	001	001	0d	0d	d0	010	0d	1d	d1	001
C	010	010	0d	d0	0d	011	0d	d0	1d	010
D	011	011	0d	d0	d0	100	1d	d1	d1	011
E	100	100	d0	0d	0d	101	d0	0d	1d	100
F	101	101	d0	0d	d0	110	d0	1d	d1	101
G	110	110	d0	d0	0d	111	d0	d0	1d	110
H	111	111	d0	d0	d0	000	d1	d1	d1	111

J_0 

	y_1y_0	00	01	11	10
wy_2	00	0	d	d	0
	01	0	d	d	0
	11	1	d	d	1
	10	1	d	d	1

	y_1y_0	00	01	11	10
wy_2	00				
	01				
	11				
	10				

 K_0

Karnaugh maps for the first JK flip-flop

	Present state $y_2y_1y_0$	Flip-flop inputs							Count $z_2z_1z_0$	
		$w = 0$				$w = 1$				
		$Y_2Y_1Y_0$	J_2K_2	J_1K_1	J_0K_0	$Y_2Y_1Y_0$	J_2K_2	J_1K_1		J_0K_0
A	000	000	0d	0d	0d	001	0d	0d	1d	000
B	001	001	0d	0d	d0	010	0d	1d	d1	001
C	010	010	0d	d0	0d	011	0d	d0	1d	010
D	011	011	0d	d0	d0	100	1d	d1	d1	011
E	100	100	d0	0d	0d	101	d0	0d	1d	100
F	101	101	d0	0d	d0	110	d0	1d	d1	101
G	110	110	d0	d0	0d	111	d0	d0	1d	110
H	111	111	d0	d0	d0	000	d1	d1	d1	111

J_0 

	y_1y_0	00	01	11	10
wy_2	00	0	d	d	0
	01	0	d	d	0
	11	1	d	d	1
	10	1	d	d	1

	y_1y_0	00	01	11	10
wy_2	00	d	0	0	d
	01	d	0	0	d
	11	d	1	1	d
	10	d	1	1	d

 K_0

Karnaugh maps for the first JK flip-flop

	Present state $y_2y_1y_0$	Flip-flop inputs								Count $z_2z_1z_0$
		$w = 0$				$w = 1$				
		$Y_2Y_1Y_0$	J_2K_2	J_1K_1	J_0K_0	$Y_2Y_1Y_0$	J_2K_2	J_1K_1	J_0K_0	
A	000	000	0d	0d	0d	001	0d	0d	1d	000
B	001	001	0d	0d	d0	010	0d	1d	d1	001
C	010	010	0d	d0	0d	011	0d	d0	1d	010
D	011	011	0d	d0	d0	100	1d	d1	d1	011
E	100	100	d0	0d	0d	101	d0	0d	1d	100
F	101	101	d0	0d	d0	110	d0	1d	d1	101
G	110	110	d0	d0	0d	111	d0	d0	1d	110
H	111	111	d0	d0	d0	000	d1	d1	d1	111

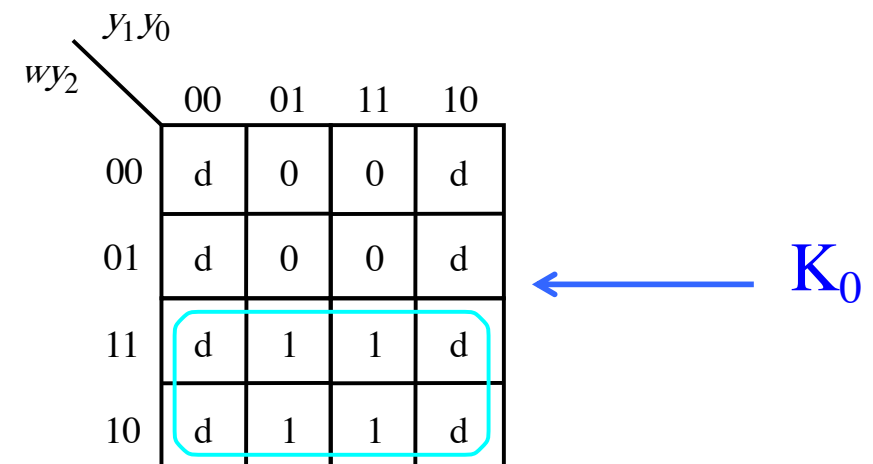
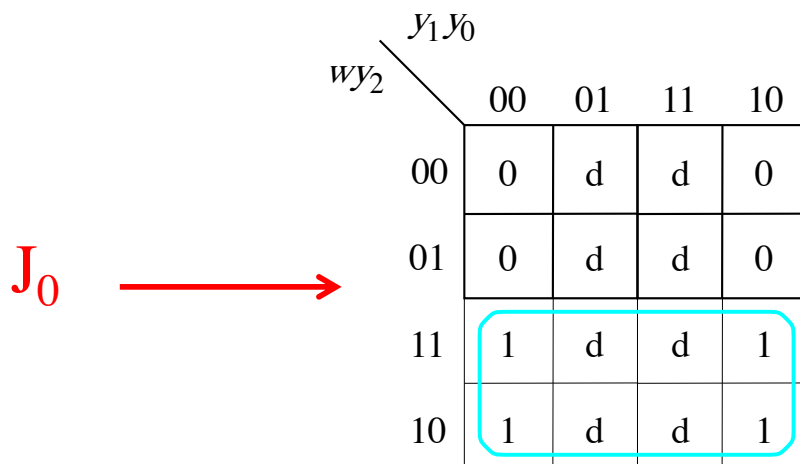

Karnaugh maps for the first JK flip-flop

	Present state $y_2y_1y_0$	Flip-flop inputs								Count $z_2z_1z_0$
		$w = 0$				$w = 1$				
		$Y_2Y_1Y_0$	J_2K_2	J_1K_1	J_0K_0	$Y_2Y_1Y_0$	J_2K_2	J_1K_1	J_0K_0	
A	000	000	0d	0d	0d	001	0d	0d	1d	000
B	001	001	0d	0d	d0	010	0d	1d	d1	001
C	010	010	0d	d0	0d	011	0d	d0	1d	010
D	011	011	0d	d0	d0	100	1d	d1	d1	011
E	100	100	d0	0d	0d	101	d0	0d	1d	100
F	101	101	d0	0d	d0	110	d0	1d	d1	101
G	110	110	d0	d0	0d	111	d0	d0	1d	110
H	111	111	d0	d0	d0	000	d1	d1	d1	111

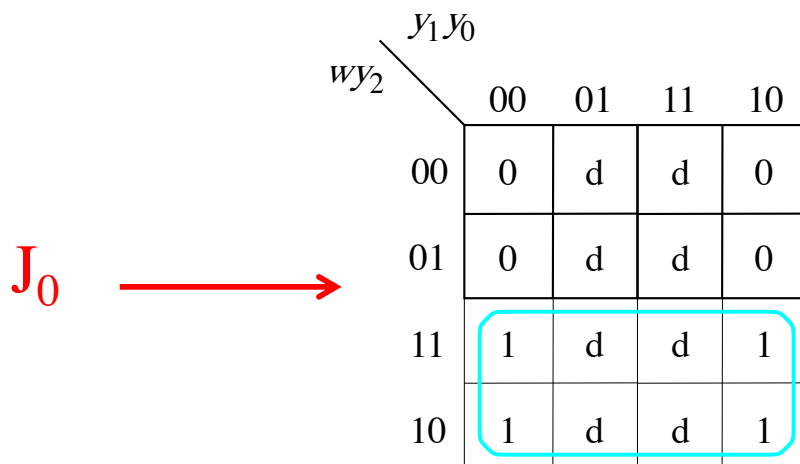

$$J_0 = w$$

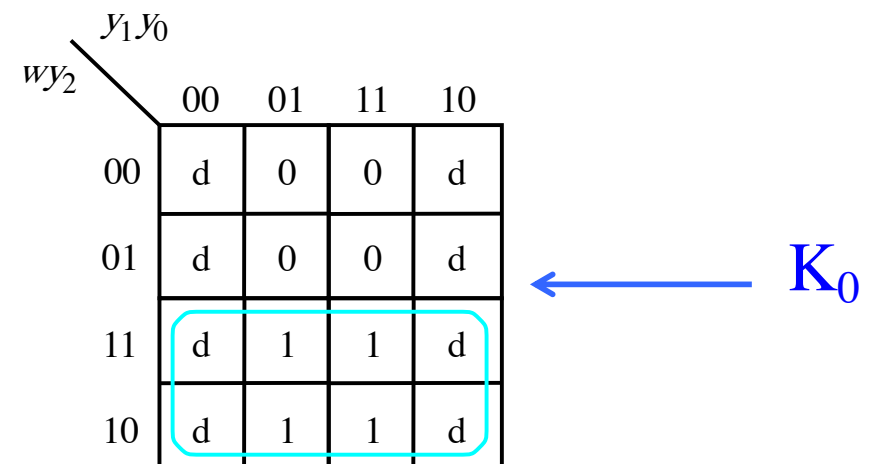

$$K_0 = w$$

Karnaugh maps for the first JK flip-flop

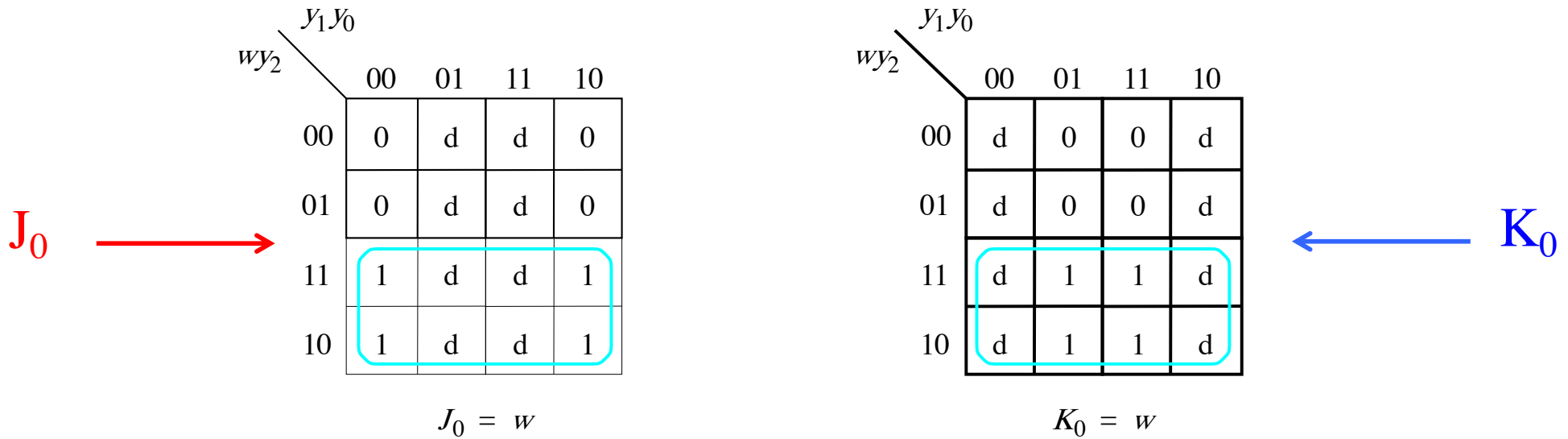

Karnaugh maps for the second JK flip-flop

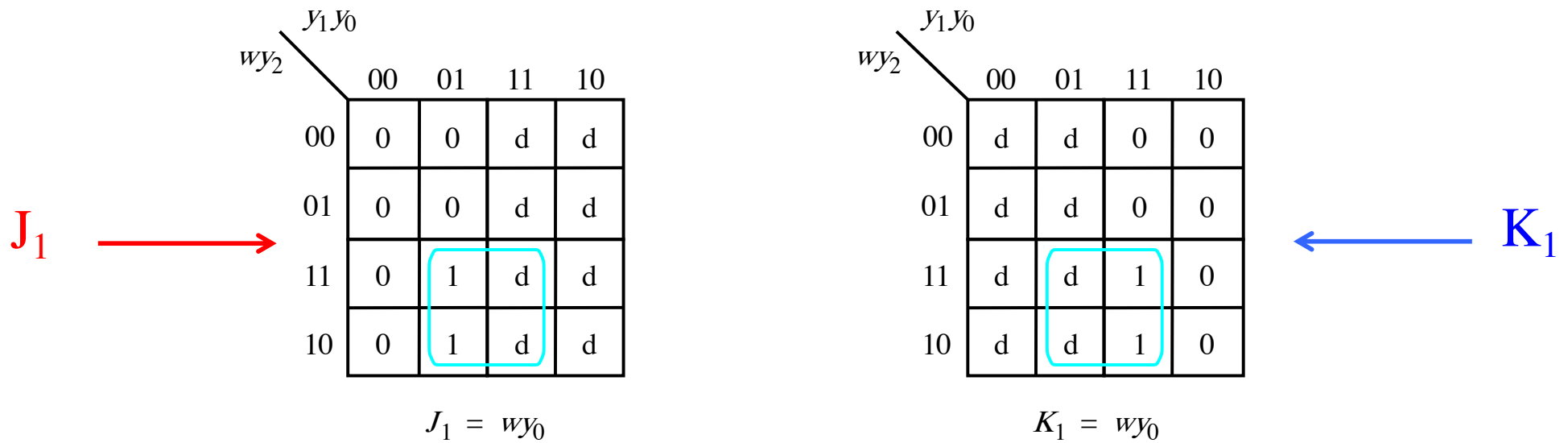

Karnaugh maps for the third JK flip-flop

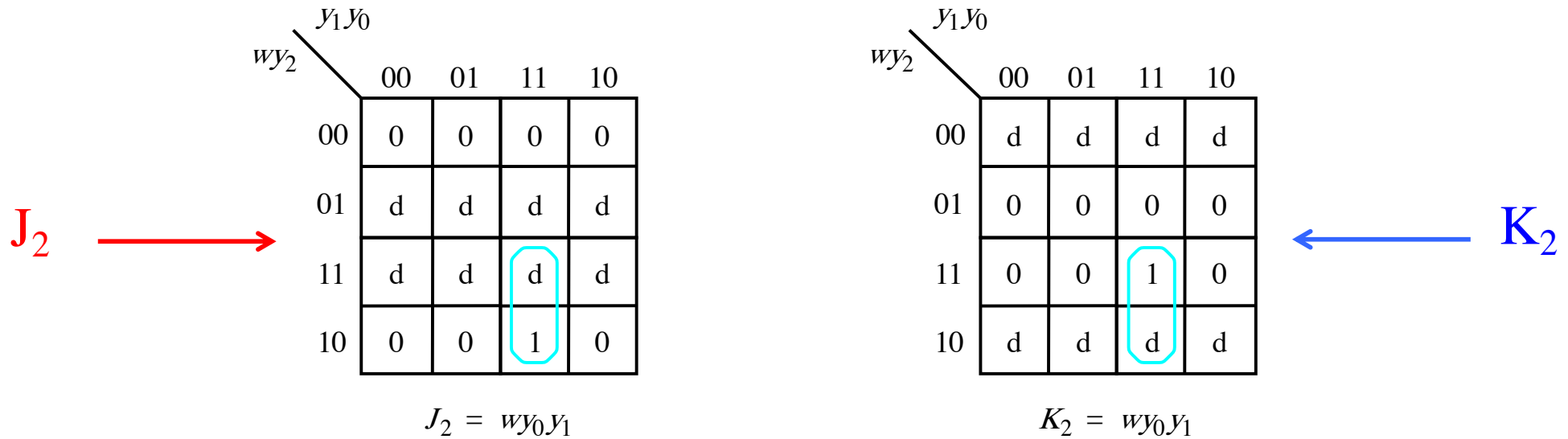

Circuit diagram using JK flip-flops

$$J_0 = w$$

$$K_0 = w$$

$$J_1 = wy_0$$

$$K_1 = wy_0$$

$$J_2 = wy_0y_1$$

$$K_2 = wy_0y_1$$

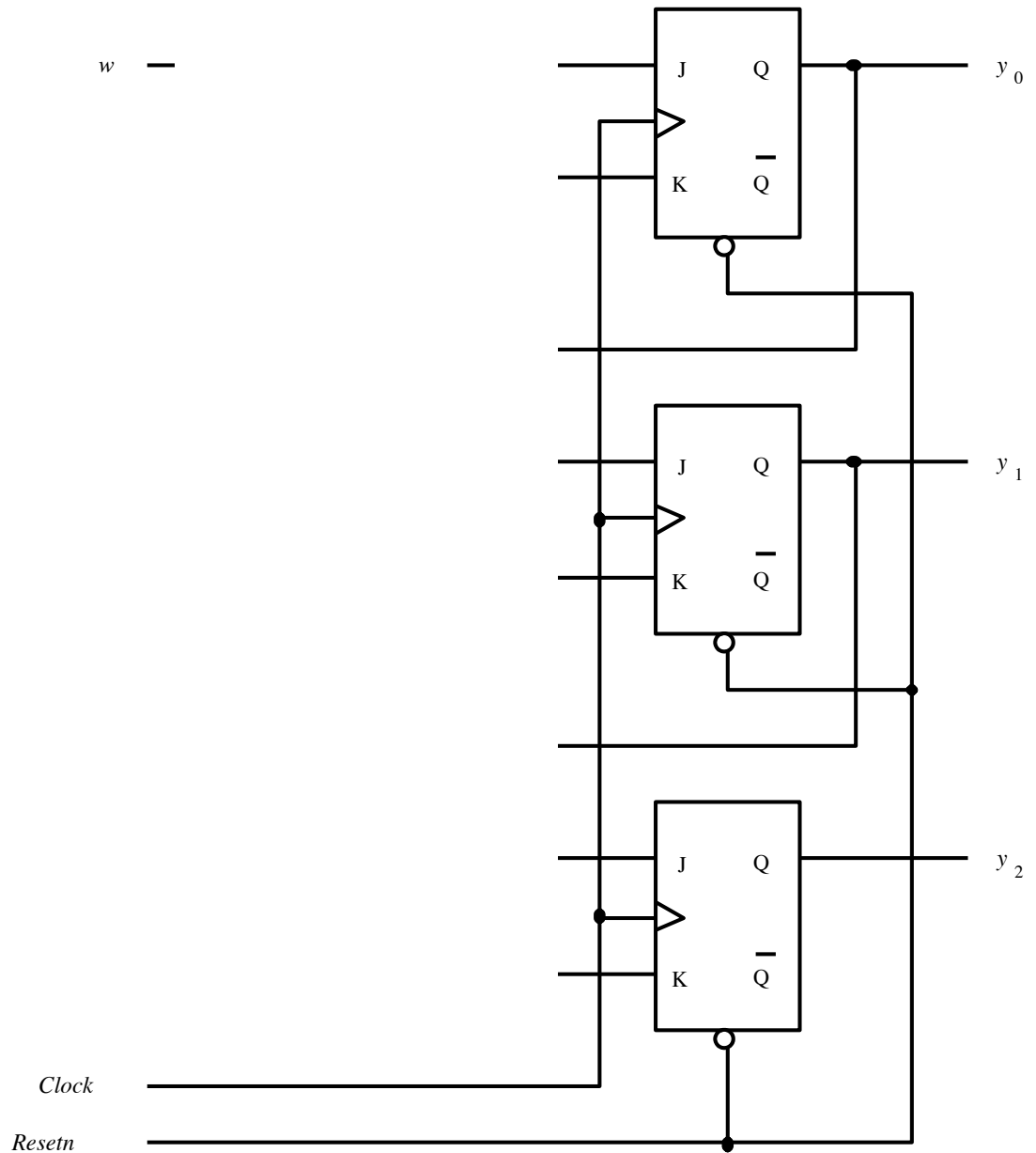

Circuit diagram using JK flip-flops

$$J_0 = w$$

$$K_0 = w$$

$$J_1 = wy_0$$

$$K_1 = wy_0$$

$$J_2 = wy_0y_1$$

$$K_2 = wy_0y_1$$

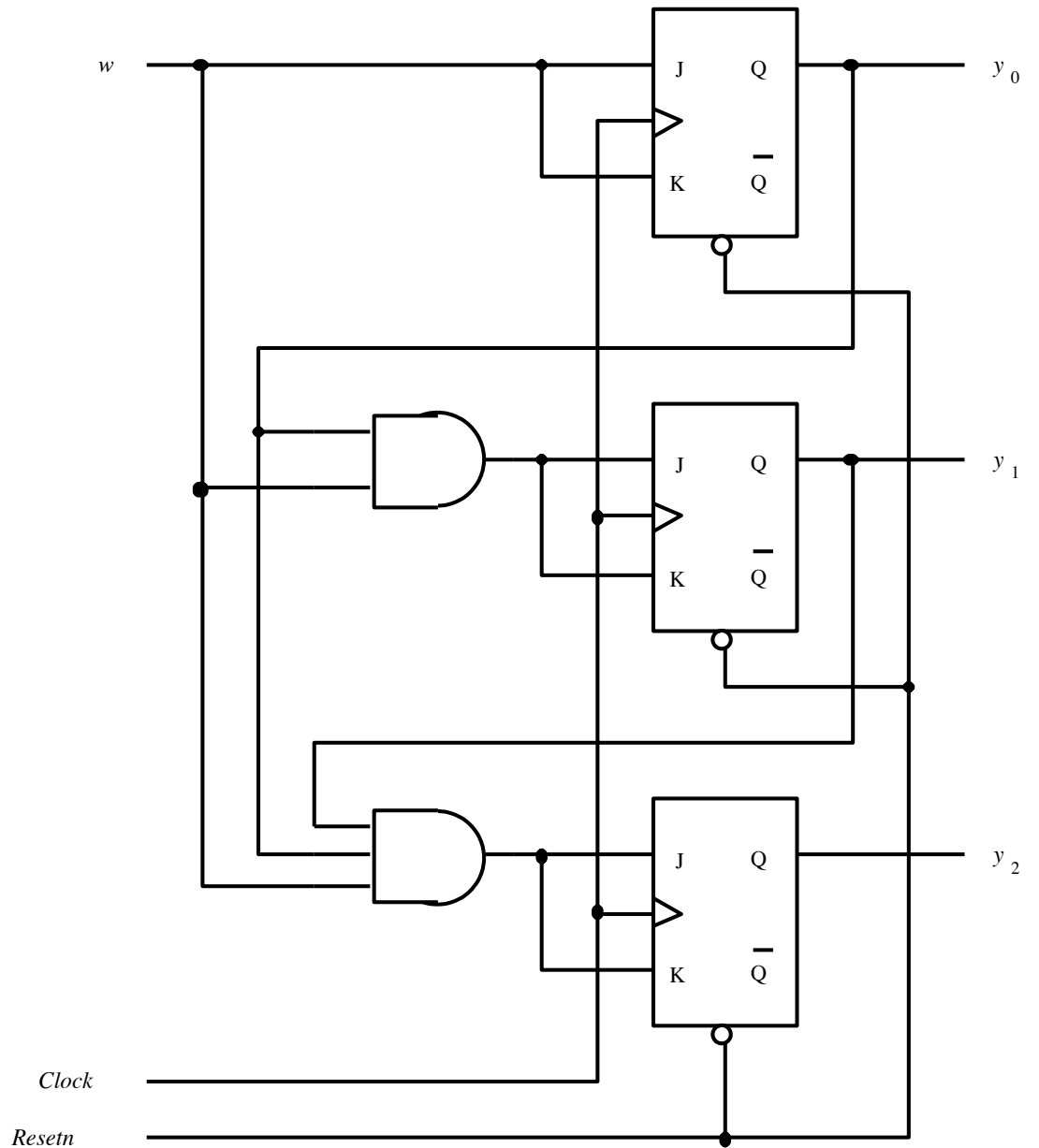

[Figure 6.67 from the textbook]

Factored-form implementation of the counter

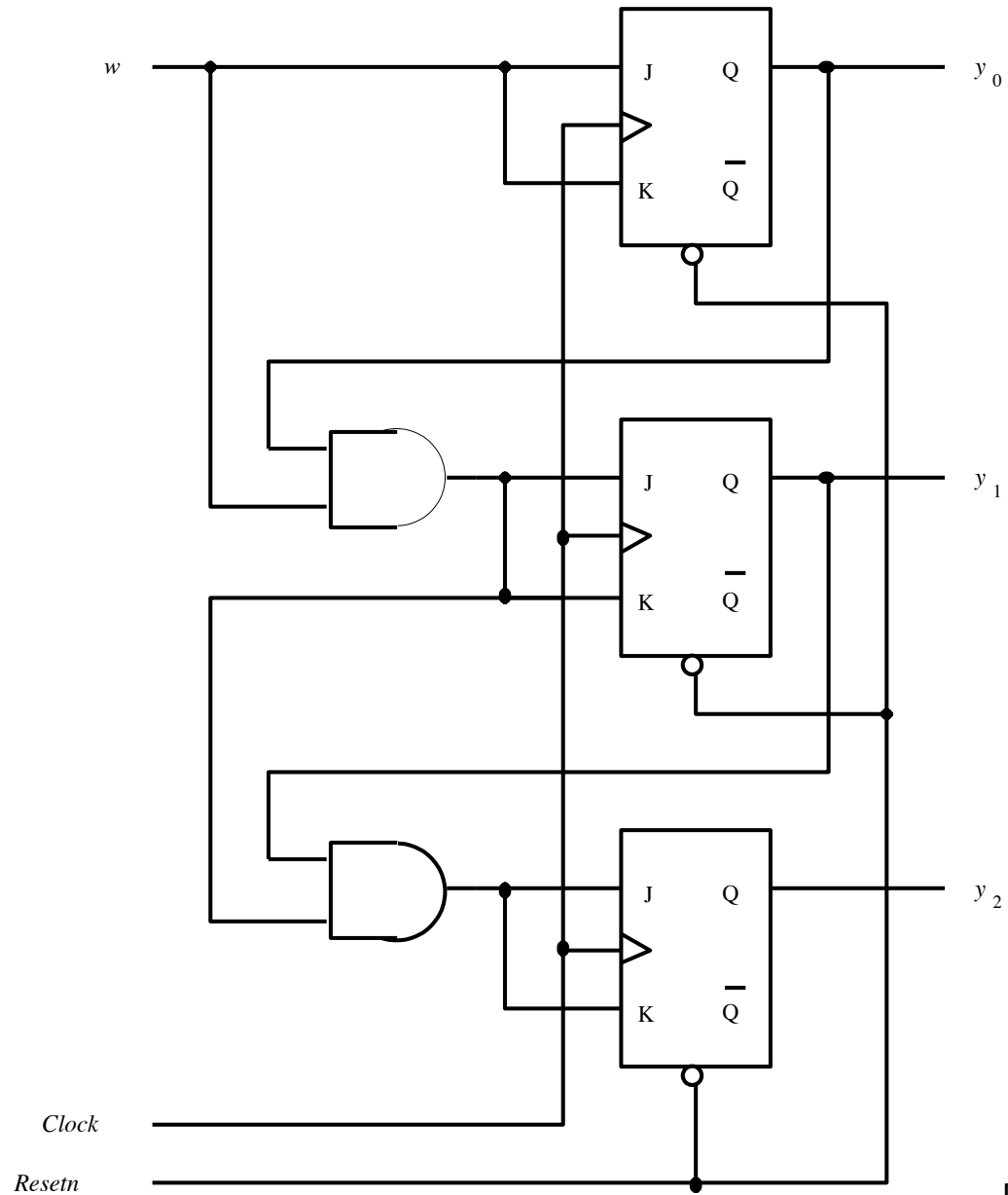

[Figure 6.68 from the textbook]

Factored-form implementation of the counter

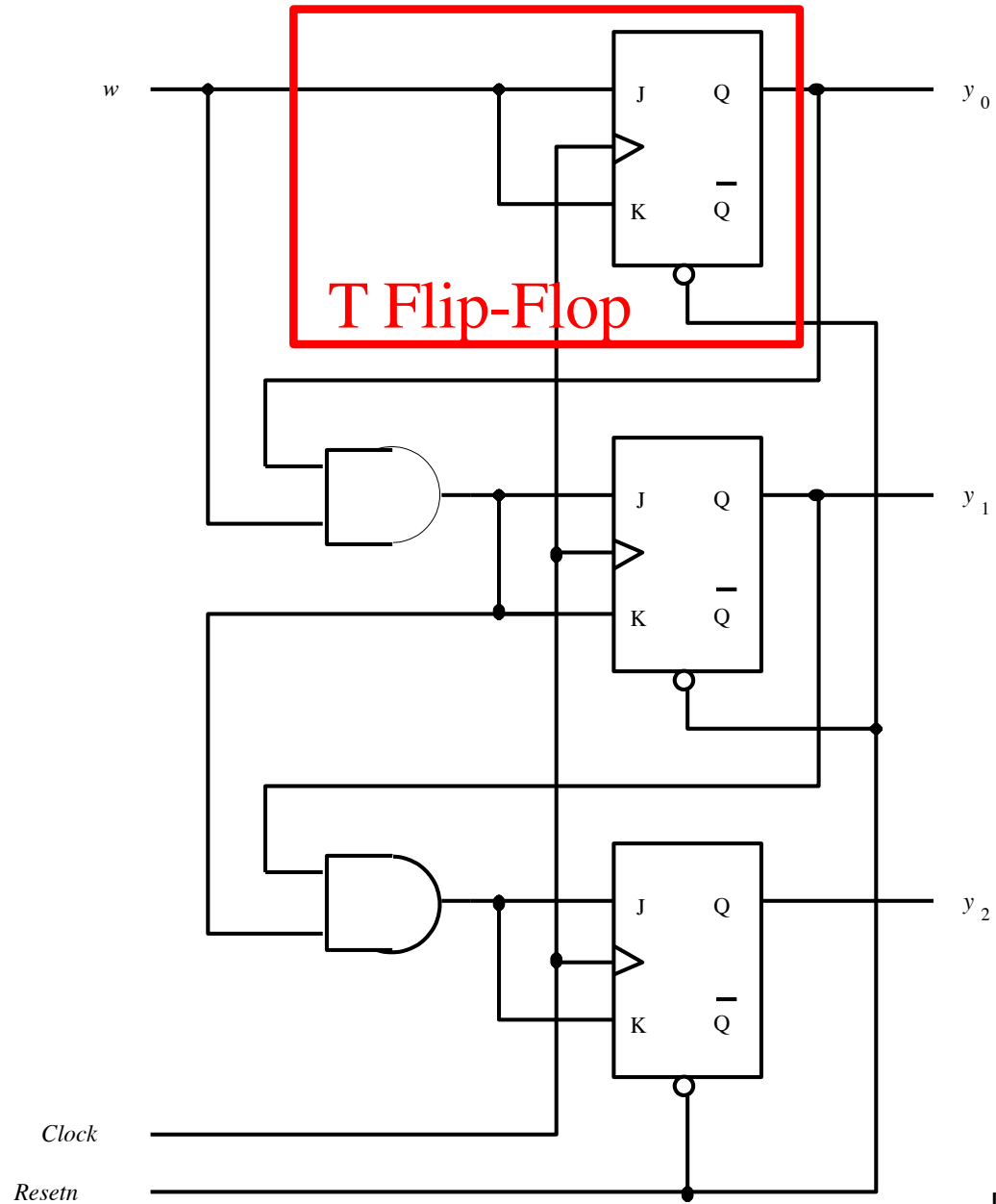

[Figure 6.68 from the textbook]

Compare with the D flip-flop implementation

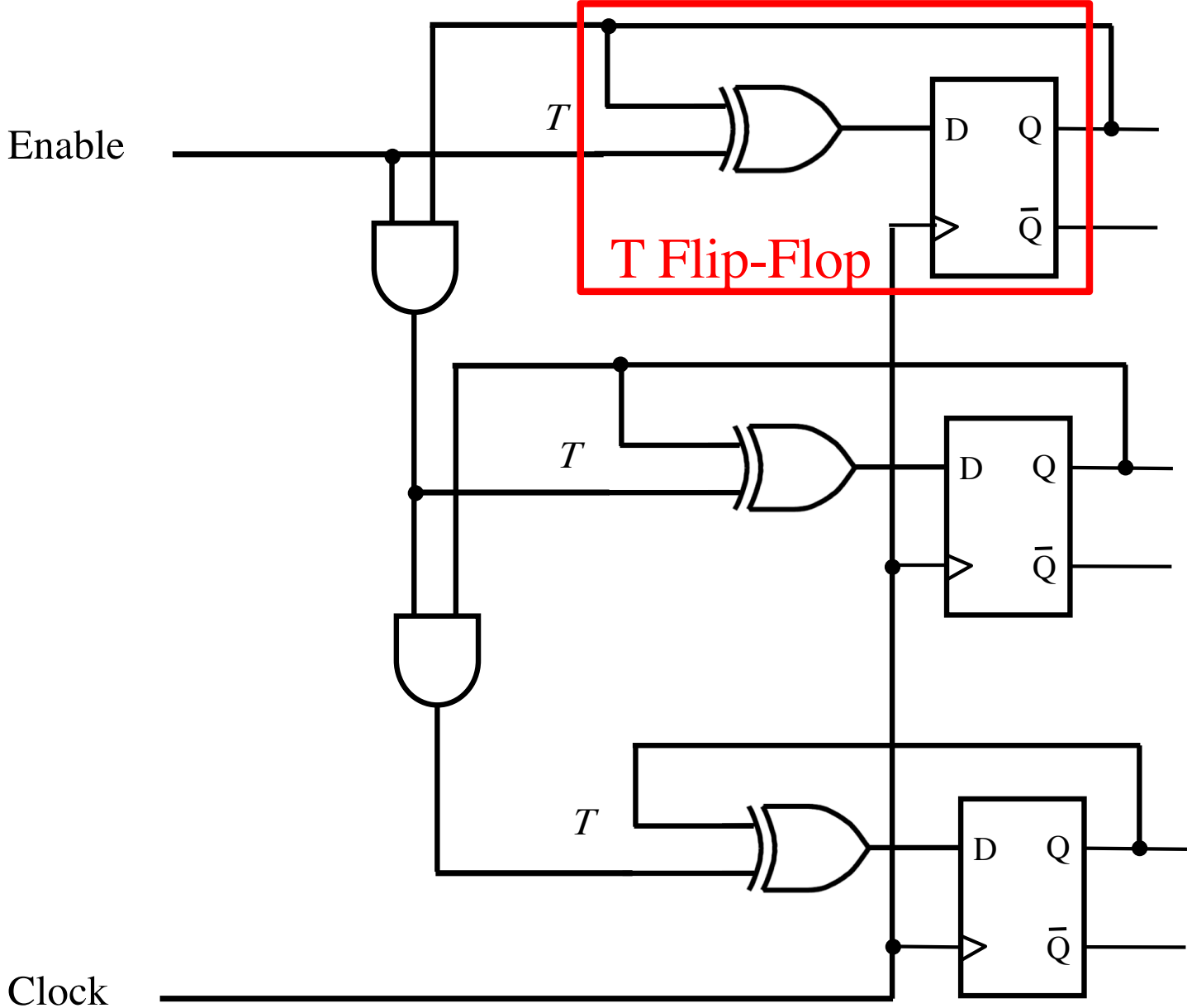

Another Example (A Different “Counter”)

Goal



- **Implement a 3-bit counter using the sequential circuit approach that counts the pulses on the input line w .**
- **The counter must count in the following sequence:
0, 4, 2, 6, 1, 5, 3, 7, 0, 4, 2, ...**
- **The count must be represented directly by the flip-flop values. No extra gates are allowed.**
- **In other words, count = $Q_2 Q_1 Q_0$**
- **The count changes based on the input signal w :**
 - **If $w=0$, then the count remains the same**
 - **If $w=1$, then the count is advanced by one**

Goal



- Implement a 3-bit counter using the sequential circuit approach that counts the pulses on the input line w .
- The counter must count in the following sequence:
0, 4, 2, 6, 1, 5, 3, 7, 0, 4, 2, ...
- The count must be represented directly by the flip-flop values. No extra gates are allowed.
- In other words, count = $Q_2 Q_1 Q_0$
- The count changes based on the input signal w :
 - If $w=0$, then the count remains the same
 - If $w=1$, then the count is advanced by one

Clock = w

By flipping the order of the bits we get

000		000
001		100
010		010
011		110
100		001
101		101
110		011
111		111

By flipping the order of the bits we get

0	000		000	0
1	001		100	4
2	010		010	2
3	011		110	6
4	100		001	1
5	101		101	5
6	110		011	3
7	111		111	7

State table for the counterlike example

Present state	Next state	Output $z_2z_1z_0$
A	B	000
B	C	100
C	D	010
D	E	110
E	F	001
F	G	101
G	H	011
H	A	111

State-assigned table for this example

Present state $y_2y_1y_0$	Next state $Y_2Y_1Y_0$	Output $z_2z_1z_0$
000	100	000
100	010	100
010	110	010
110	001	110
001	101	001
101	011	101
011	111	011
111	000	111

K-maps for Y_2 , Y_1 , and Y_0

Present state $y_2y_1y_0$	Next state $Y_2Y_1Y_0$	Output $z_2z_1z_0$
000	100	000
100	010	100
010	110	010
110	001	110
001	101	001
101	011	101
011	111	011
111	000	111

		y_1y_0			
y_2		00	01	11	10
0					
1					

K-maps for Y_2 , Y_1 , and Y_0

Present state $y_2y_1y_0$	Next state $Y_2Y_1Y_0$	Output $z_2z_1z_0$
000	100	000
100	010	100
010	110	010
110	001	110
001	101	001
101	011	101
011	111	011
111	000	111

$y_2 \backslash y_1y_0$	00	01	11	10
0				
1				

Notice that these
are scrambled

K-maps for Y_2 , Y_1 , and Y_0

Present state $y_2y_1y_0$	Next state $Y_2Y_1Y_0$	Output $z_2z_1z_0$
000	100	000
100	010	100
010	110	010
110	001	110
001	101	001
101	011	101
011	111	011
111	000	111

$y_2 \backslash y_1y_0$	00	01	11	10
0				
1				

Notice that these
are scrambled

K-map for Y_2

Present state $y_2y_1y_0$	Next state $Y_2Y_1Y_0$	Output $z_2z_1z_0$
000	100	000
100	010	100
010	110	010
110	001	110
001	101	001
101	011	101
011	111	011
111	000	111

$y_2 \backslash y_1y_0$	00	01	11	10
0				
1				

K-map for Y_2

Present state $y_2y_1y_0$	Next state $Y_2Y_1Y_0$	Output $z_2z_1z_0$
000	100	000
100	010	100
010	110	010
110	001	110
001	101	001
101	011	101
011	111	011
111	000	111

$y_2 \backslash y_1y_0$	00	01	11	10
0				
1				

K-map for Y_2

Present state $y_2y_1y_0$	Next state $Y_2Y_1Y_0$	Output $z_2z_1z_0$
000	100	000
100	010	100
010	110	010
110	001	110
001	101	001
101	011	101
011	111	011
111	000	111

$y_2 \backslash y_1y_0$	00	01	11	10
0	1	1	1	1
1	0	0	0	0

K-map for Y_2

Present state $y_2y_1y_0$	Next state $Y_2Y_1Y_0$	Output $z_2z_1z_0$
000	100	000
100	010	100
010	110	010
110	001	110
001	101	001
101	011	101
011	111	011
111	000	111

$y_2 \backslash y_1y_0$	00	01	11	10
0	1	1	1	1
1	0	0	0	0

$$Y_2 = \overline{y_2}$$

K-map for Y_1

Present state $y_2y_1y_0$	Next state $Y_2Y_1Y_0$	Output $z_2z_1z_0$
000	100	000
100	010	100
010	110	010
110	001	110
001	101	001
101	011	101
011	111	011
111	000	111

$y_2 \backslash y_1y_0$	00	01	11	10
0				
1				

K-map for Y_1

Present state $y_2y_1y_0$	Next state $Y_2Y_1Y_0$	Output $z_2z_1z_0$
000	100	000
100	010	100
010	110	010
110	001	110
001	101	001
101	011	101
011	111	011
111	000	111

$y_2 \backslash y_1y_0$	00	01	11	10
0				
1				

K-map for Y_1

Present state $y_2y_1y_0$	Next state $Y_2Y_1Y_0$	Output $z_2z_1z_0$
000	100	000
100	010	100
010	110	010
110	001	110
001	101	001
101	011	101
011	111	011
111	000	111

$y_2 \backslash y_1y_0$	00	01	11	10
0	0	0	1	1
1	1	1	0	0

K-map for Y_1

Present state $y_2y_1y_0$	Next state $Y_2Y_1Y_0$	Output $z_2z_1z_0$
000	100	000
100	010	100
010	110	010
110	001	110
001	101	001
101	011	101
011	111	011
111	000	111

		y_1y_0			
		00	01	11	10
y_2	0	0	0	1	1
	1	1	1	0	0

$$Y_1 = y_2\bar{y}_1 + \bar{y}_2y_1$$

XOR

K-map for Y_0

Present state $y_2y_1y_0$	Next state $Y_2Y_1Y_0$	Output $z_2z_1z_0$
000	100	000
100	010	100
010	110	010
110	001	110
001	101	001
101	011	101
011	111	011
111	000	111

$y_2 \backslash y_1y_0$	00	01	11	10
0				
1				

K-map for Y_0

Present state $y_2y_1y_0$	Next state $Y_2Y_1Y_0$	Output $z_2z_1z_0$
000	100	000
100	010	100
010	110	010
110	001	110
001	101	001
101	011	101
011	111	011
111	000	111

$y_2 \backslash y_1y_0$	00	01	11	10
0	0	1	1	0
1	0	1	0	1

K-map for Y_0

Present state $y_2y_1y_0$	Next state $Y_2Y_1Y_0$	Output $z_2z_1z_0$
000	100	000
100	010	100
010	110	010
110	001	110
001	101	001
101	011	101
011	111	011
111	000	111

$y_2 \backslash y_1y_0$	00	01	11	10
0	0	1	1	0
1	0	1	0	1

$$Y_0 = \bar{y}_1y_0 + \bar{y}_2y_0 + y_2y_1\bar{y}_0$$

K-map for Y_0

Present state $y_2 y_1 y_0$	Next state $Y_2 Y_1 Y_0$	Output $z_2 z_1 z_0$
000	100	000
100	010	100
010	110	010
110	001	110
001	101	001
101	011	101
011	111	011
111	000	111

$y_2 \backslash y_1 y_0$	00	01	11	10
0	0	1	1	0
1	0	1	0	1

$$\begin{aligned}
 Y_0 &= \bar{y}_1 y_0 + \bar{y}_2 y_0 + y_2 y_1 \bar{y}_0 \\
 &= (\bar{y}_1 + \bar{y}_2) y_0 + y_2 y_1 \bar{y}_0 \\
 &= (\overline{y_1 y_2}) y_0 + (y_2 y_1) \bar{y}_0 \\
 &= (y_1 y_2) \oplus y_0
 \end{aligned}$$

Let's Draw the Circuit for this example

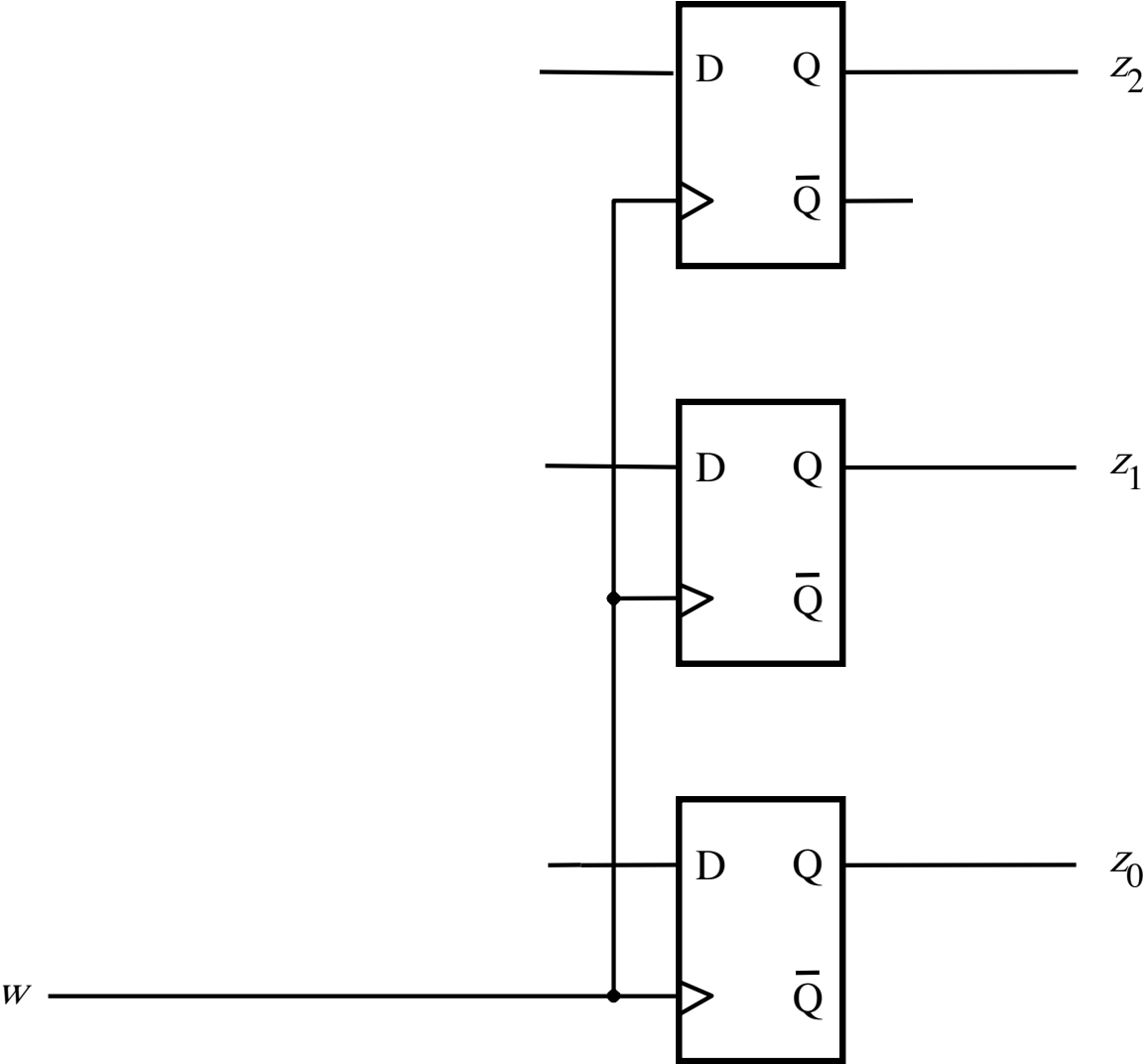

Let's Draw the Circuit for this example

$$Y_2 = \overline{y_2}$$

$$Y_1 = y_1 \oplus y_2$$

$$Y_0 = (y_1 y_2) \oplus y_0$$

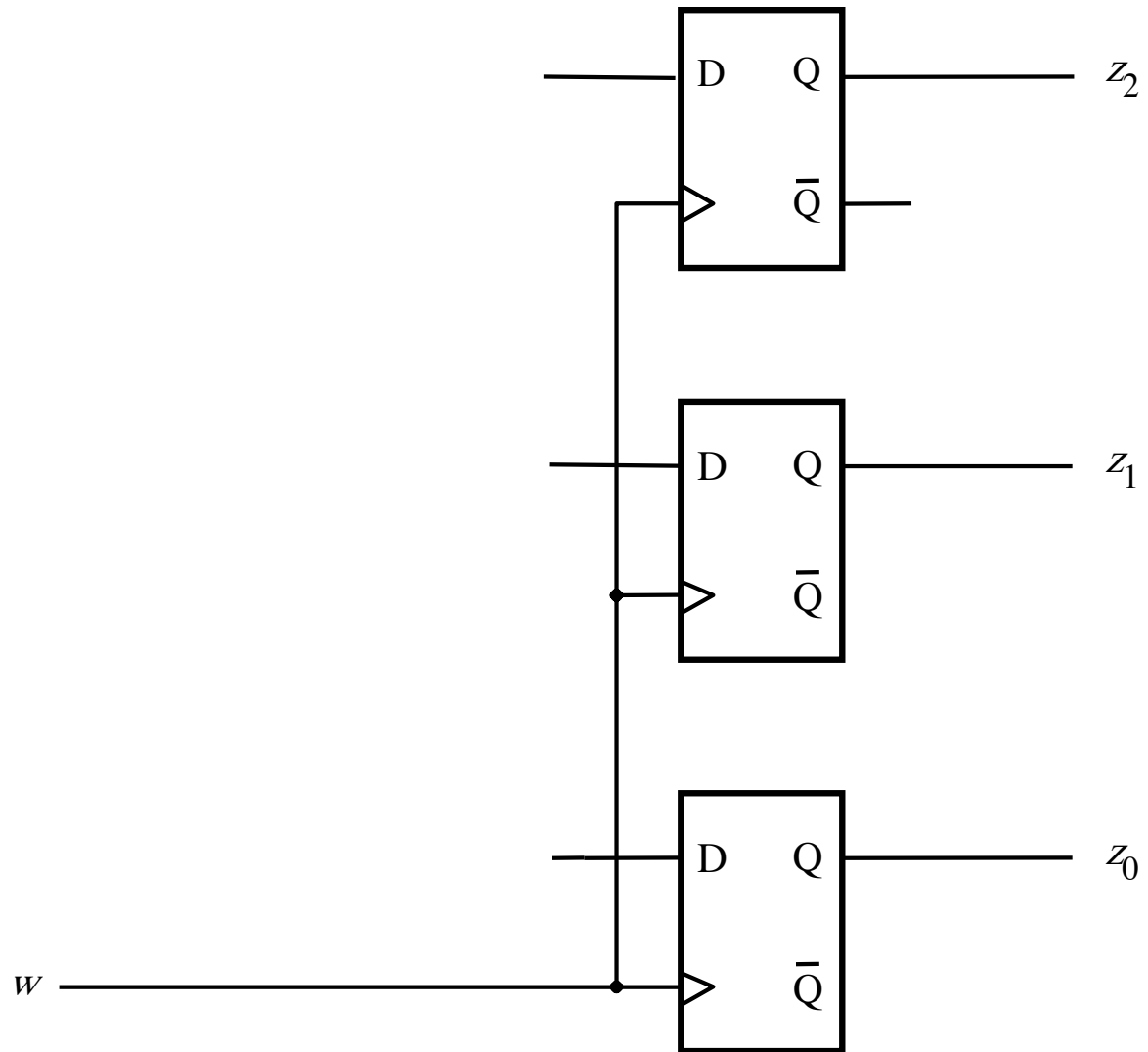

The Circuit for this example

$$Y_2 = \overline{y_2}$$

$$Y_1 = y_1 \oplus y_2$$

$$Y_0 = (y_1 y_2) \oplus y_0$$

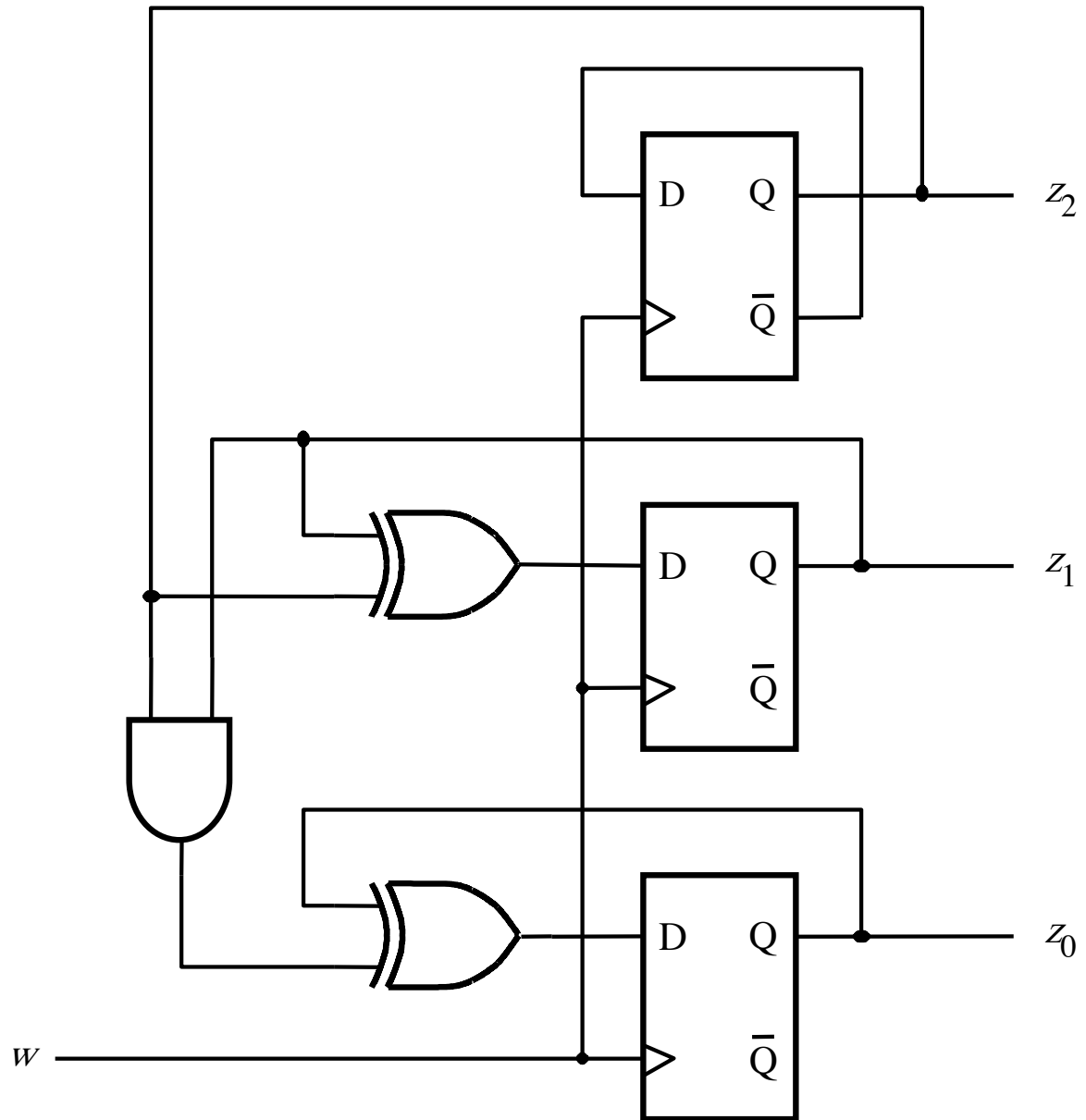

[Figure 6.71 from the textbook]

Questions?

THE END