

# **CprE 281: Digital Logic**

**Instructor: Alexander Stoytchev**

**<http://www.ece.iastate.edu/~alexs/classes/>**

# Algorithmic State Machine (ASM) Charts

*CprE 281: Digital Logic  
Iowa State University, Ames, IA  
Copyright © Alexander Stoytchev*

# Administrative Stuff

- **Homework 12 is out**
- **It is due on Wednesday November 30 @ 10pm**
- **Final Project Proposals**
  - **Did you hear back from your TAs?**
  - **Did you make the changes that they recommended?**

# **Administrative Stuff**

- **Extra credit lab is due on December 2 @ 10 pm**

# Administrative Stuff

- **Final Project: due during your last lab (dead week).**
  - **The grading rubric is posted on the class web page.**
  - **presentation of your work to your TAs**
  - **final report pdf (upload on canvas)**
  - **zip file with your design (upload on canvas)**
  - **If you work in a team: each student needs to present separately to their lab TAs.**

# **Administrative Stuff**

- **The FINAL exam is scheduled for**

**Wednesday Dec 14 @ 2:15 – 4:15 PM**

# Reading Material for Next Lecture

- **“The Seven Secrets of Computer Power Revealed” by Daniel Dennett.**
- **This is Chapter 24 in his book “Intuition Pumps and Other Tools for Thinking”, 2013**

# **Algorithmic State Machine (ASM) Charts**



# Elements used in ASM charts

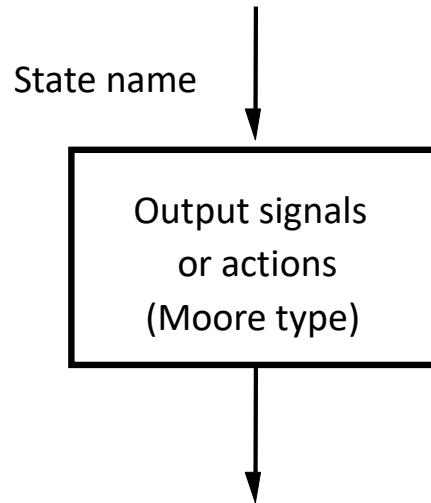

(a) State box

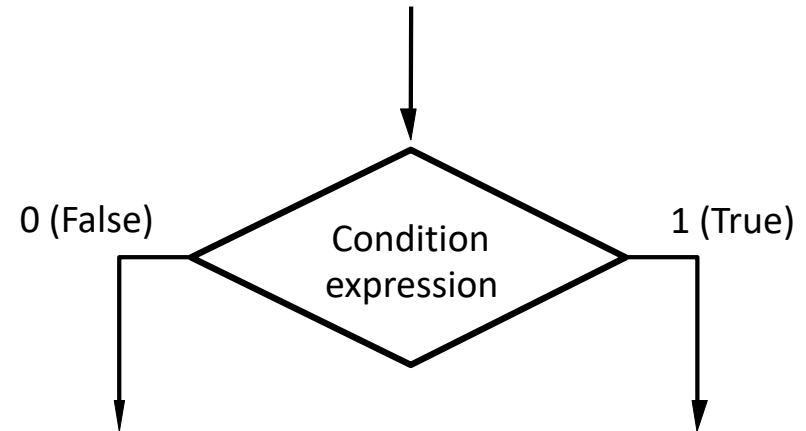

(b) Decision box

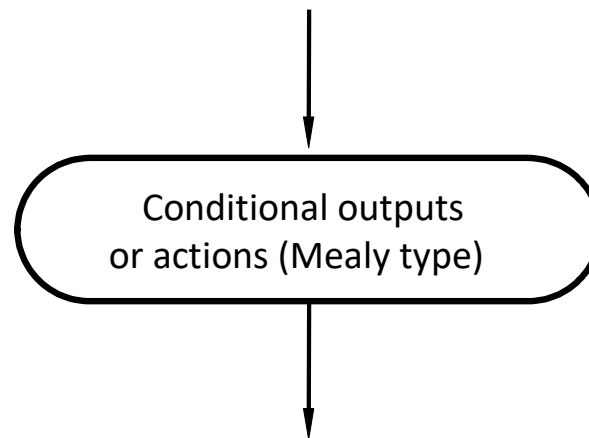

(c) Conditional output box

# State Box

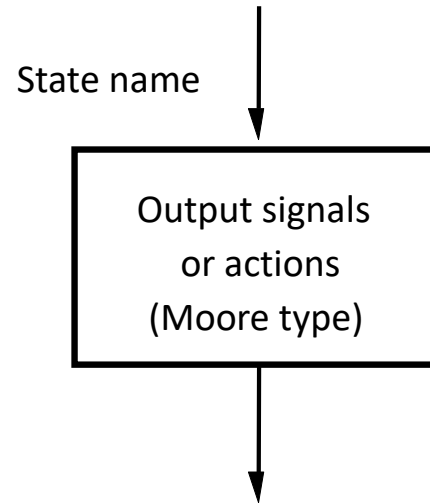

# State Box

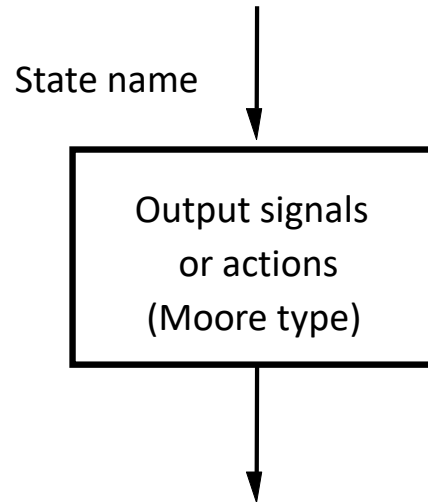

- **Indicated with a rectangle**
- **Equivalent to a node in the State diagram**
- **The name of the state is written outside the box**
- **Moore-type outputs are written inside the box**
- **Only the output that must be set to 1 is written (by default, if an output is not listed it is set to 0)**

# Decision Box

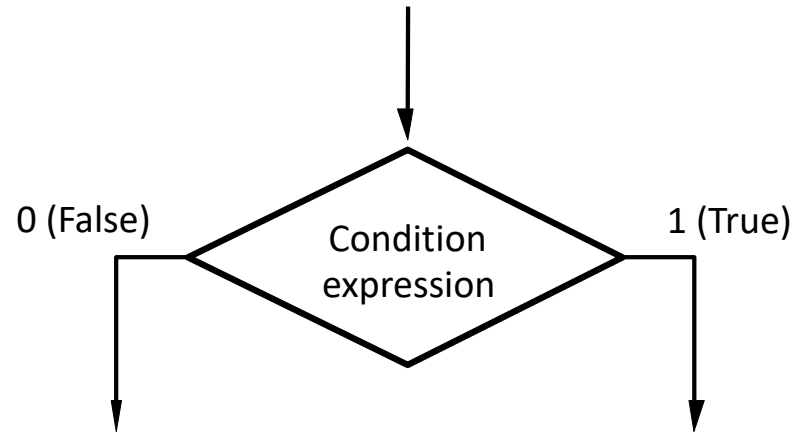

# Decision Box

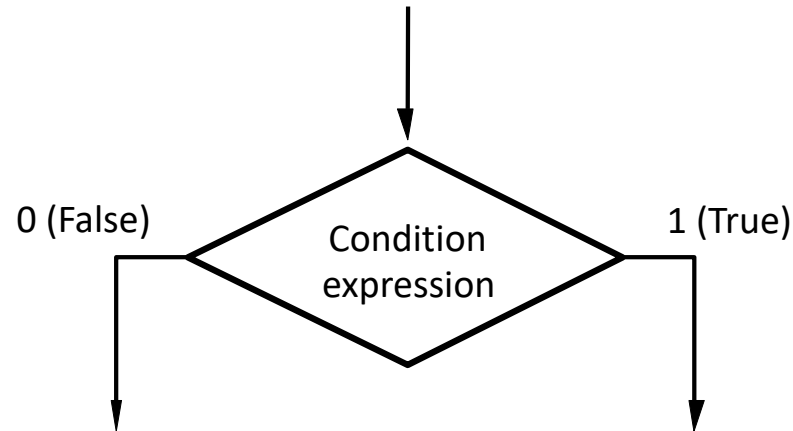

- **Indicated with a diamond shape**
- **Used for a condition expression that must be tested**
- **The exit path is chosen based on the outcome of the test**
- **The condition is on one or more inputs to the FSM**
- **Shortcut notation: w means “is w equal to 1?”**

# Conditional Output Box

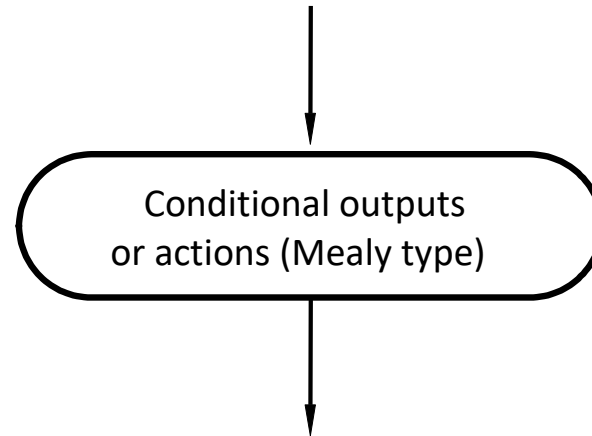

- **Indicated with an oval shape**
- **Used for a Mealy-type output signals**
- **The outputs depend on the state variables and inputs**
- **The condition that determines when such outputs are generated is placed in a separate decision box**

# **Some Examples**

# Moore FSM

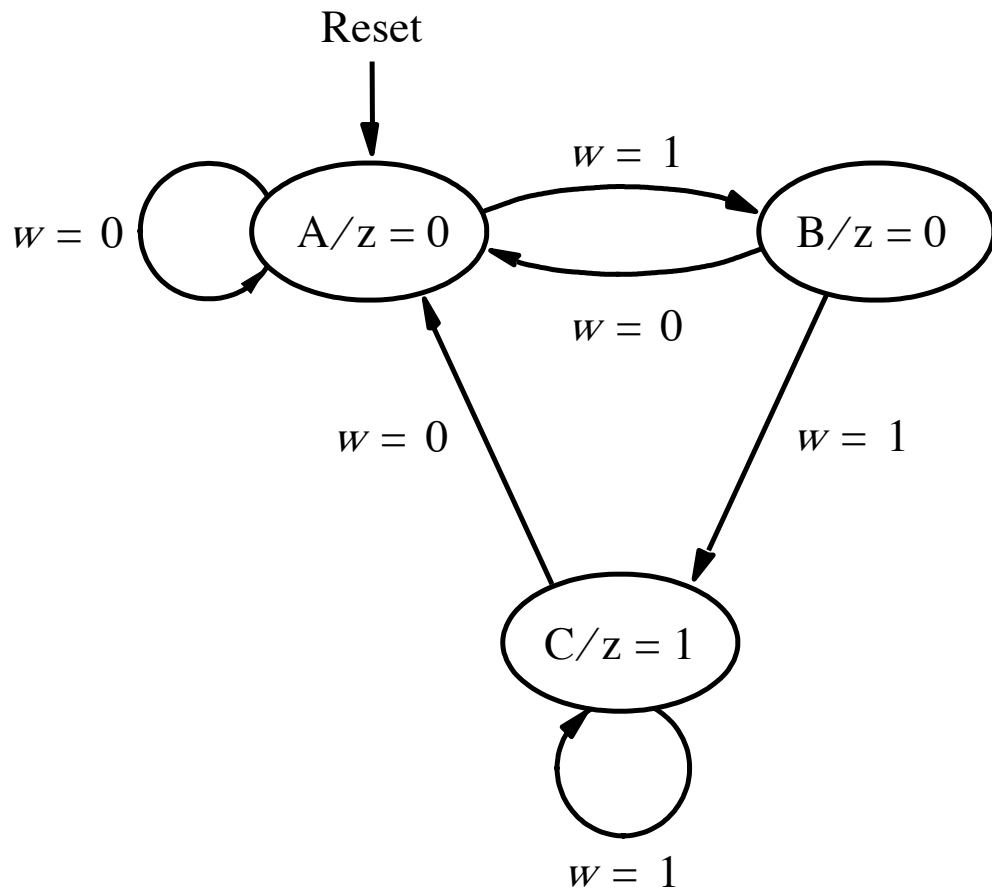

[ Figure 6.3 from the textbook ]

# ASM chart

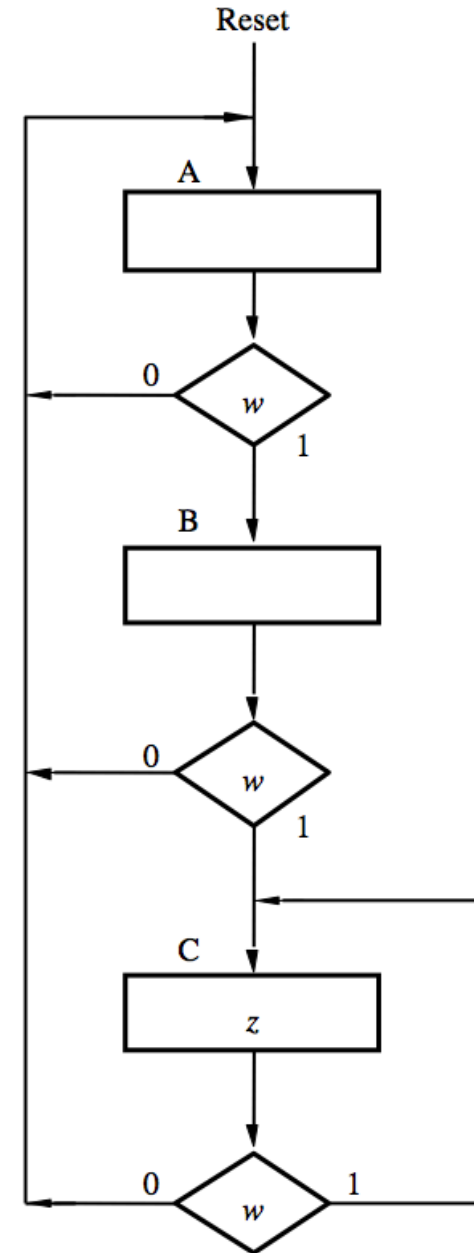

[ Figure 6.82 from the textbook ]



# Mealy FSM

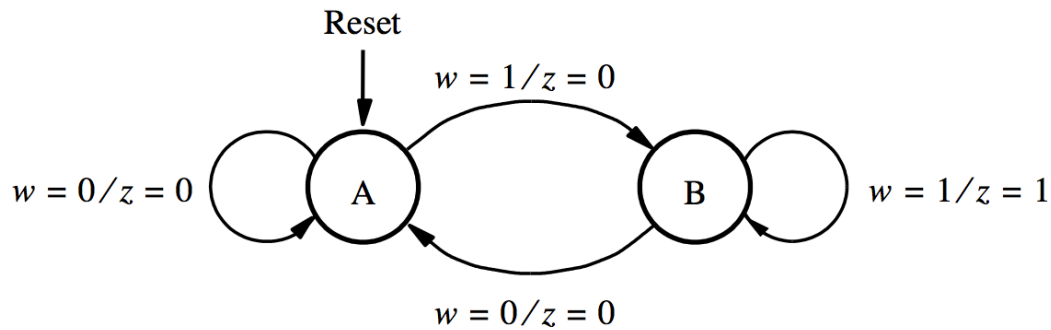

[ Figure 6.23 from the textbook ]

# ASM chart

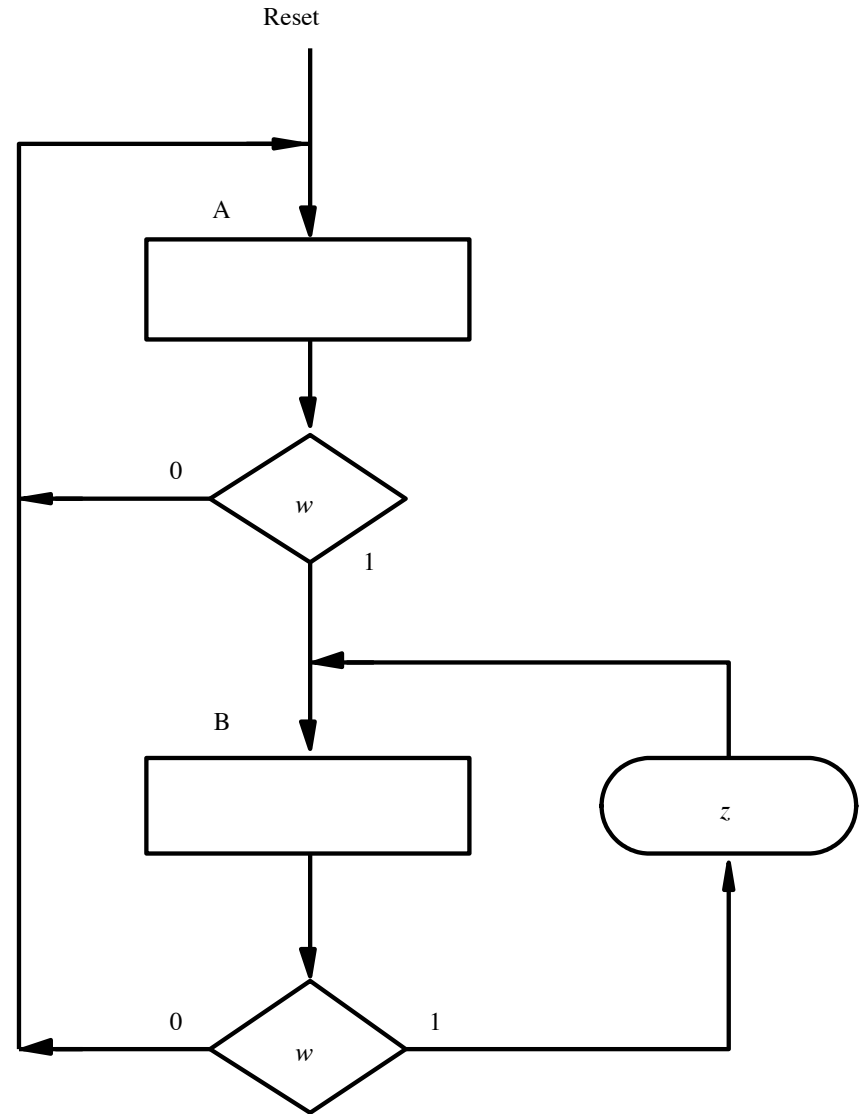

[ Figure 6.83 from the textbook ]

# FSM

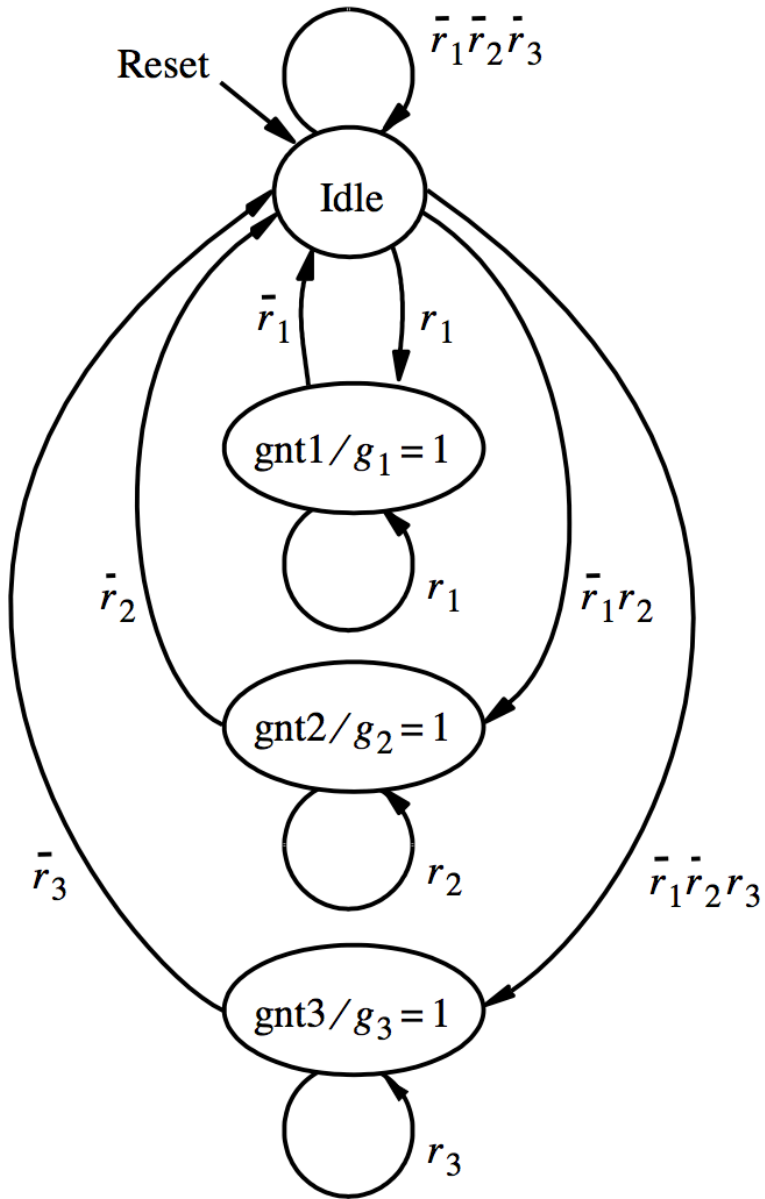

[ Figure 6.73 from the textbook ]

# ASM chart

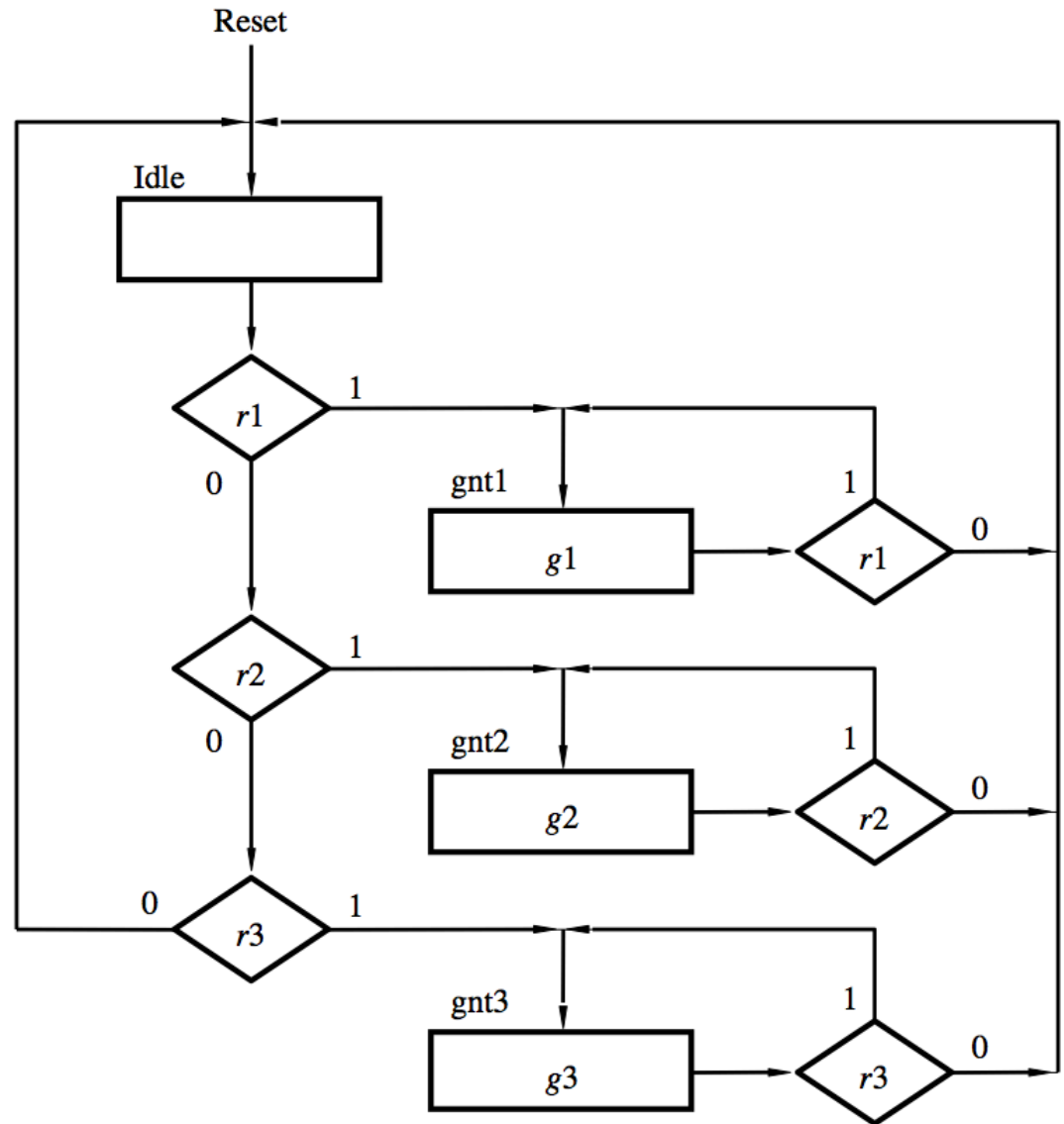

[ Figure 6.84 from the textbook ]

# **ASM Chart is different from a Flow Chart**

- **The ASM chart implicitly includes timing info**
- **It is assumed that the underlying FSM changes from one state to another on every active clock edge**
- **Flow charts don't make that assumption.**

# The general model for a sequential circuit

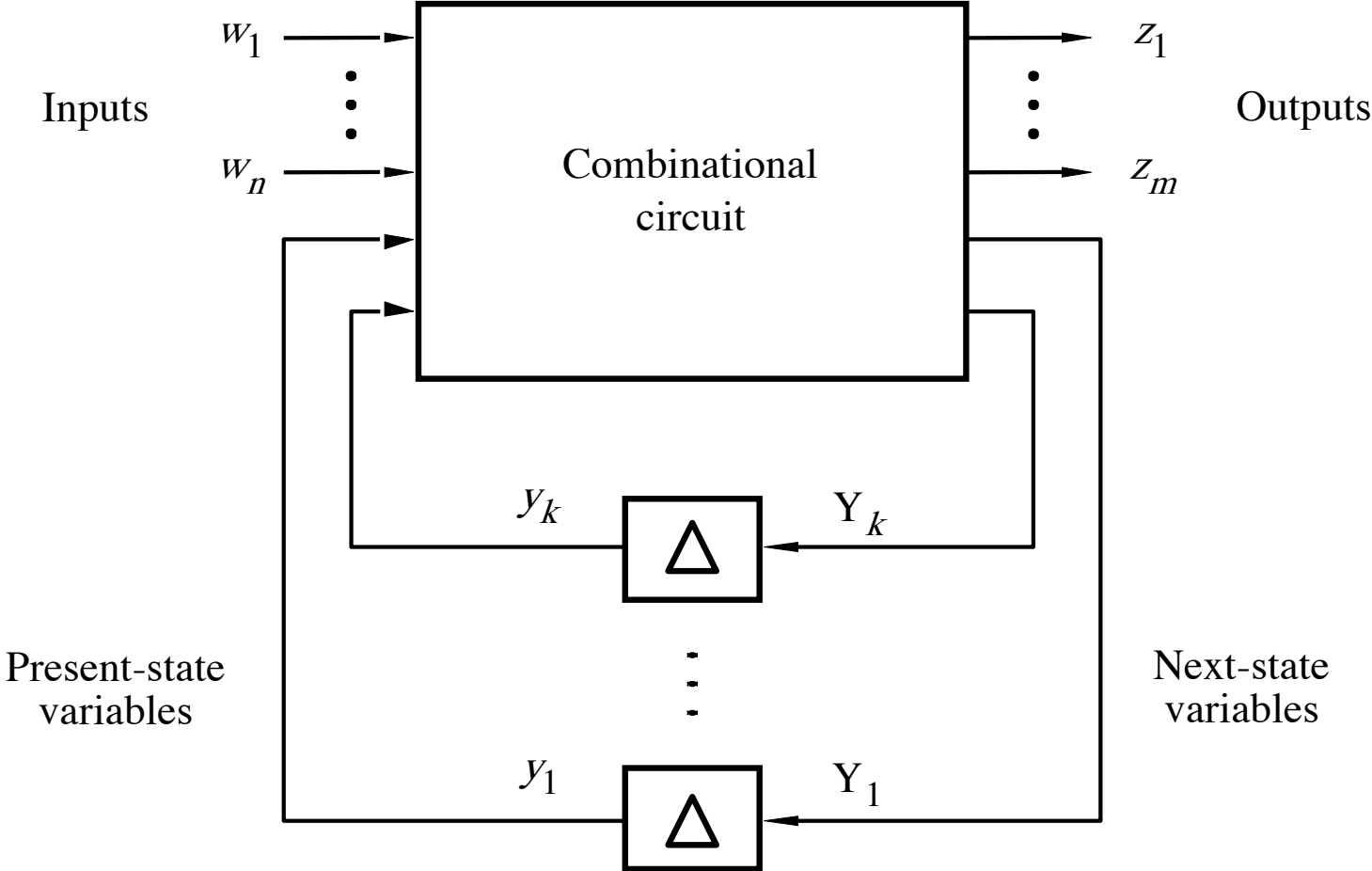

[ Figure 6.85 from the textbook ]

# The general model for a sequential circuit

$$M = (W, Z, S, \varphi, \lambda)$$

- $W$ ,  $Z$ , and  $S$  are finite, nonempty sets of inputs, outputs, and states, respectively.
- $\varphi$  is the state transition function, such that  $S(t + 1) = \varphi[W(t), S(t)]$ .
- $\lambda$  is the output function, such that  $\lambda(t) = \lambda[S(t)]$  for the Moore model and  $\lambda(t) = \lambda[W(t), S(t)]$  for the Mealy model.

# **Examples of Solved Problems**

# **Example 6.12**

# Goal

- **Design an FSM that detects if the previous two values of the input  $w$  were equal to 00 or 11.**
- **If either condition is true then the output  $z$  should be set to 1; otherwise to 0.**



# State Diagram

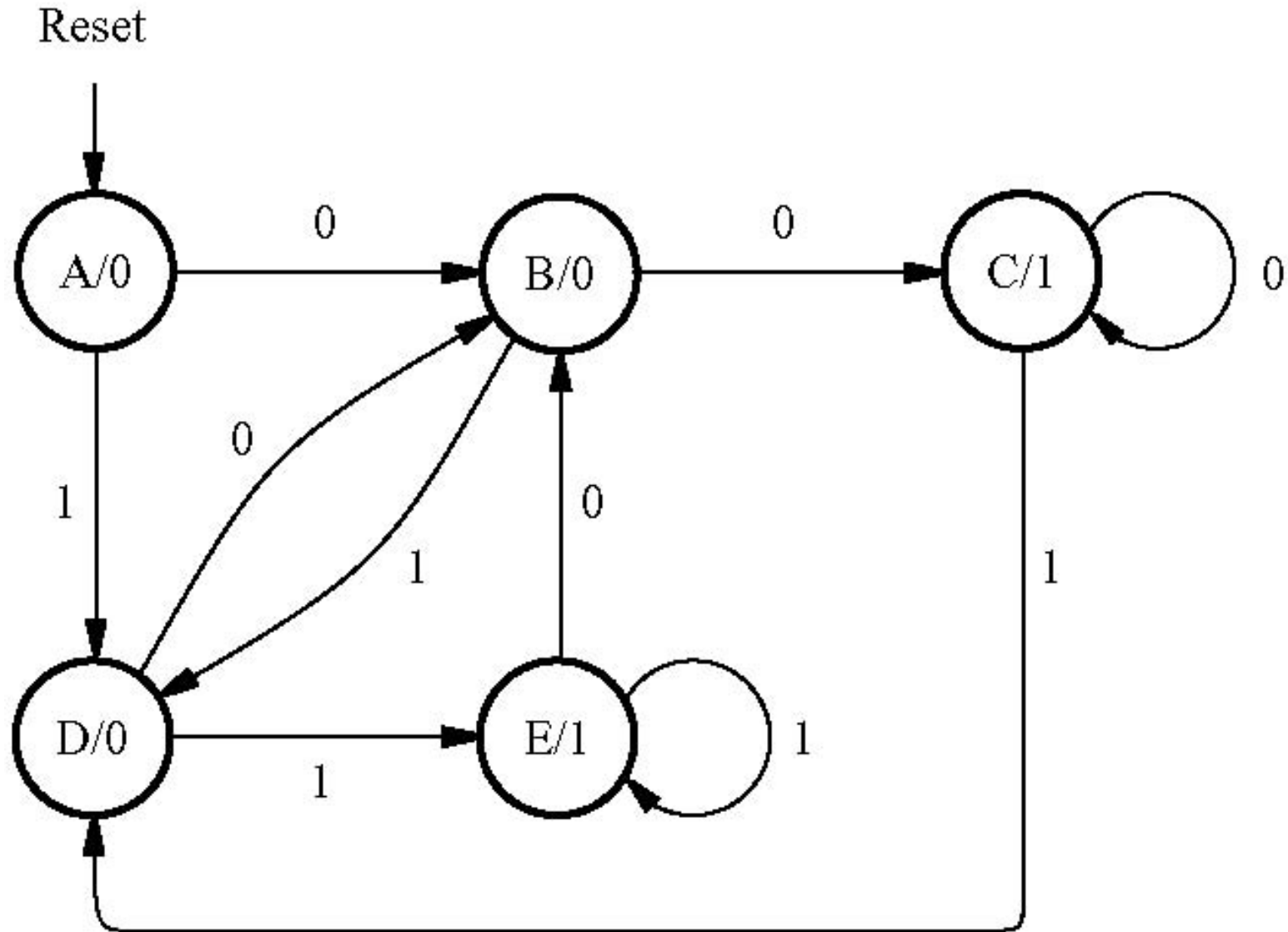

[ Figure 6.86 from the textbook ]

# State Table for the FSM

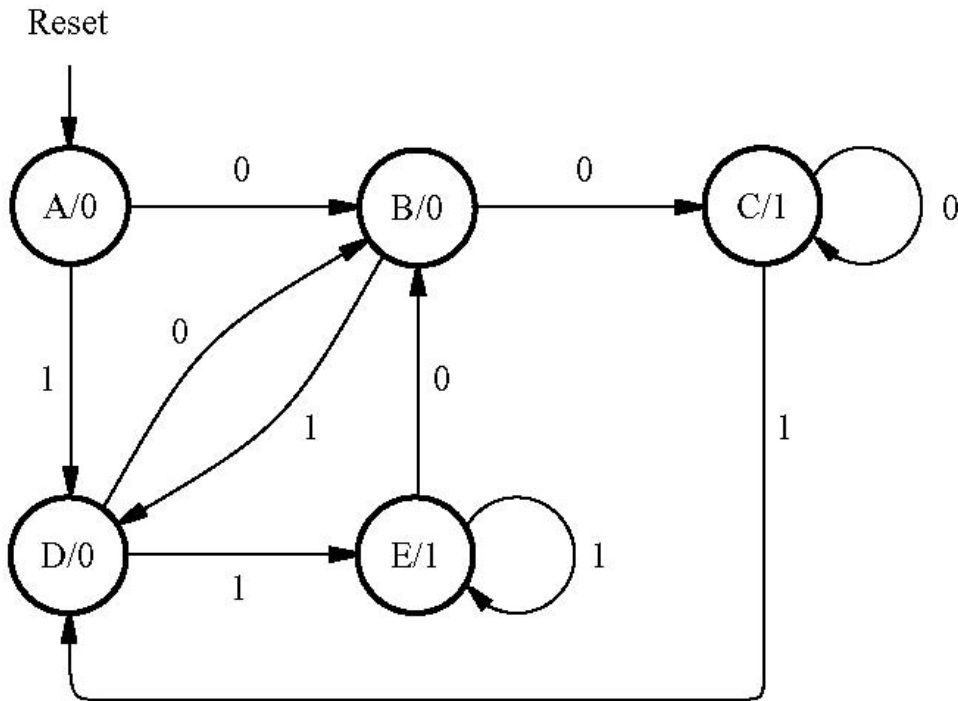

Present state	Next state		Output $z$
	$w = 0$	$w = 1$	
A	B	D	0
B	C	D	0
C	C	D	1
D	B	E	0
E	B	E	1

[ Figure 6.86 from the textbook ]

[ Figure 6.87 from the textbook ]

# State Table for the FSM

Present state	Next state		Output $z$
	$w = 0$	$w = 1$	
A	B	D	0
B	C	D	0
C	C	D	1
D	B	E	0
E	B	E	1

# State-Assigned Table for the FSM

Present state	Next state		Output $z$
	$w = 0$	$w = 1$	
A	B	D	0
B	C	D	0
C	C	D	1
D	B	E	0
E	B	E	1

	Present state $y_3y_2y_1$	Next state		Output $z$
		$w = 0$	$w = 1$	
		$Y_3Y_2Y_1$	$Y_3Y_2Y_1$	
A	000	001	011	0
B	001	010	011	0
C	010	010	011	1
D	011	001	100	0
E	100	001	100	1

# State-Assigned Table for the FSM

	Present state $y_3y_2y_1$	Next state		Output $z$
		$w = 0$	$w = 1$	
		$Y_3Y_2Y_1$	$Y_3Y_2Y_1$	
A	000	001	011	0
B	001	010	011	0
C	010	010	011	1
D	011	001	100	0
E	100	001	100	1

# State-Assigned Table for the FSM

	Present state $y_3y_2y_1$	Next state		Output $z$
		$w = 0$	$w = 1$	
		$Y_3Y_2Y_1$	$Y_3Y_2Y_1$	
A	000	001	011	0
B	001	010	011	0
C	010	010	011	1
D	011	001	100	0
E	100	001	100	1

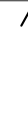

$$z = y_3 + \bar{y}_1 y_2$$

How can we derive this expression?

# State-Assigned Table for the FSM

	Present state $y_3y_2y_1$	Next state		Output $z$
		$w = 0$	$w = 1$	
		$Y_3Y_2Y_1$	$Y_3Y_2Y_1$	
A	000	001	011	0
B	001	010	011	0
C	010	010	011	1
D	011	001	100	0
E	100	001	100	1
	101	ddd	ddd	d
	110	ddd	ddd	d
	111	ddd	ddd	d

# Truth Table for the Output $z$

	Present state $y_3y_2y_1$	Next state		Output $z$
		$w = 0$	$w = 1$	
		$Y_3Y_2Y_1$	$Y_3Y_2Y_1$	
A	000	001	011	0
B	001	010	011	0
C	010	010	011	1
D	011	001	100	0
E	100	001	100	1
	<b>101</b>	<u>ddd</u>	<u>ddd</u>	<b>d</b>
	<b>110</b>	<u>ddd</u>	<u>ddd</u>	<b>d</b>
	<b>111</b>	<u>ddd</u>	<u>ddd</u>	<b>d</b>

$y_3$	$y_2$	$y_1$	$z$
0	0	0	
0	0	1	
0	1	0	
0	1	1	
1	0	0	
1	0	1	
1	1	0	
1	1	1	



# Truth Table for the Output $z$

	Present state $y_3y_2y_1$	Next state		Output $z$
		$w = 0$	$w = 1$	
		$Y_3Y_2Y_1$	$Y_3Y_2Y_1$	
A	000	001	011	0
B	001	010	011	0
C	010	010	011	1
D	011	001	100	0
E	100	001	100	1
	101	<u>ddd</u>	<u>ddd</u>	d
	110	<u>ddd</u>	<u>ddd</u>	d
	111	<u>ddd</u>	<u>ddd</u>	d

$y_3$	$y_2$	$y_1$	$z$
0	0	0	0
0	0	1	0
0	1	0	1
0	1	1	0
1	0	0	1
1	0	1	d
1	1	0	d
1	1	1	d

# Truth Table for the Output $z$

	Present state $y_3y_2y_1$	Next state		Output $z$
		$w = 0$	$w = 1$	
		$Y_3Y_2Y_1$	$Y_3Y_2Y_1$	
A	000	001	011	0
B	001	010	011	0
C	010	010	011	1
D	011	001	100	0
E	100	001	100	1
	101	<u>ddd</u>	<u>ddd</u>	<u>d</u>
	110	<u>ddd</u>	<u>ddd</u>	<u>d</u>
	111	<u>ddd</u>	<u>ddd</u>	<u>d</u>

$y_3$	$y_2$	$y_1$	$z$
0	0	0	0
0	0	1	0
0	1	0	1
0	1	1	0
1	0	0	1
1	0	1	d
1	1	0	d
1	1	1	d

# K-Map for the Output z

	Present state $y_3y_2y_1$	Next state		Output $z$
		$w = 0$	$w = 1$	
		$Y_3Y_2Y_1$	$Y_3Y_2Y_1$	
A	000	001	011	0
B	001	010	011	0
C	010	010	011	1
D	011	001	100	0
E	100	001	100	1
	101	<u>ddd</u>	<u>ddd</u>	d
	110	<u>ddd</u>	<u>ddd</u>	d
	111	<u>ddd</u>	<u>ddd</u>	d

z

$y_3y_2$

$y_1$

	00	01	11	10
0	0	1	d	1
1	0	0	d	d

$y_3$	$y_2$	$y_1$	$z$
0	0	0	0
0	0	1	0
0	1	0	1
0	1	1	0
1	0	0	1
1	0	1	d
1	1	0	d
1	1	1	d

# The Expression for the Output z

	Present state $y_3y_2y_1$	Next state		Output $z$
		$w = 0$	$w = 1$	
		$Y_3Y_2Y_1$	$Y_3Y_2Y_1$	
A	000	001	011	0
B	001	010	011	0
C	010	010	011	1
D	011	001	100	0
E	100	001	100	1
	<b>101</b>	<u>ddd</u>	<u>ddd</u>	<b>d</b>
	<b>110</b>	<u>ddd</u>	<u>ddd</u>	<b>d</b>
	<b>111</b>	<u>ddd</u>	<u>ddd</u>	<b>d</b>

$y_1$	$y_3y_2$	$\overline{Y_1} Y_2$	$Y_3$
	00	01	11
0	0	1	d
1	0	0	d

$y_3$	$y_2$	$y_1$	$z$
0	0	0	0
0	0	1	0
0	1	0	1
0	1	1	0
1	0	0	1
1	0	1	d
1	1	0	d
1	1	1	d

# State-Assigned Table for the FSM

	Present state $y_3y_2y_1$	Next state		Output $z$
		$w = 0$	$w = 1$	
		$Y_3Y_2Y_1$	$Y_3Y_2Y_1$	
A	000	001	011	0
B	001	010	011	0
C	010	010	011	1
D	011	001	100	0
E	100	001	100	1

$$Y_1 = w\bar{y}_1\bar{y}_3 + w\bar{y}_2\bar{y}_3 + \bar{w}y_1y_2 + \bar{w}\bar{y}_1\bar{y}_2$$

$$Y_2 = y_1\bar{y}_2 + \bar{y}_1y_2 + w\bar{y}_2\bar{y}_3$$

$$Y_3 = wy_3 + wy_1y_2$$

How can we derive these expressions?

# Truth Table for $Y_3$

	Present state $y_3y_2y_1$	Next state		Output $z$
		$w = 0$	$w = 1$	
		$Y_3Y_2Y_1$	$Y_3Y_2Y_1$	
A	000	001	011	0
B	001	010	011	0
C	010	010	011	1
D	011	001	100	0
E	100	001	100	1
	101	ddd	ddd	d
	110	ddd	ddd	d
	111	ddd	ddd	d

$w$	$y_3$	$y_2$	$y_1$	$Y_3$	$Y_2$	$Y_1$
0	0	0	0	0		
0	0	0	1	0		
0	0	1	0	0		
0	0	1	1	0		
0	1	0	0	0		
0	1	0	1	d		
0	1	1	0	d		
0	1	1	1	d		
1	0	0	0	0		
1	0	0	1	0		
1	0	1	0	0		
1	0	1	1	1		
1	1	0	0	1		
1	1	0	1	d		
1	1	1	0	d		
1	1	1	1	d		

# Truth Table for $Y_2$

	Present state $y_3y_2y_1$	Next state		Output $z$
		$w = 0$	$w = 1$	
		$Y_3Y_2Y_1$	$Y_3Y_2Y_1$	
A	000	001	011	0
B	001	010	011	0
C	010	010	011	1
D	011	001	100	0
E	100	001	100	1
	101	ddd	ddd	d
	110	ddd	ddd	d
	111	ddd	ddd	d

$w$	$y_3$	$y_2$	$y_1$	$Y_3$	$Y_2$	$Y_1$
0	0	0	0	0	0	
0	0	0	1	0	1	
0	0	1	0	0	1	
0	0	1	1	0	0	
0	1	0	0	0	0	
0	1	0	1	d	d	
0	1	1	0	d	d	
0	1	1	1	d	d	
1	0	0	0	0	1	
1	0	0	1	0	1	
1	0	1	0	0	1	
1	0	1	1	1	0	
1	1	0	0	1	0	
1	1	0	1	d	d	
1	1	1	0	d	d	
1	1	1	1	d	d	

# Truth Table for $Y_1$

	Present state $y_3y_2y_1$	Next state		Output $z$
		$w = 0$	$w = 1$	
		$Y_3Y_2Y_1$	$Y_3Y_2Y_1$	
A	000	001	011	0
B	001	010	011	0
C	010	010	011	1
D	011	001	100	0
E	100	001	100	1
	101	ddd	ddd	d
	110	ddd	ddd	d
	111	ddd	ddd	d

$w$	$y_3$	$y_2$	$y_1$	$Y_3$	$Y_2$	$Y_1$
0	0	0	0	0	0	1
0	0	0	1	0	1	0
0	0	1	0	0	1	0
0	0	1	1	0	0	1
0	1	0	0	0	0	1
0	1	0	1	d	d	d
0	1	1	0	d	d	d
0	1	1	1	d	d	d
1	0	0	0	0	1	1
1	0	0	1	0	1	1
1	0	1	0	0	1	1
1	0	1	1	1	0	0
1	1	0	0	1	0	0
1	1	0	1	d	d	d
1	1	1	0	d	d	d
1	1	1	1	d	d	d



# K-Maps for $Y_3, Y_2, Y_1$

$Y_3$

$w y_3$	$y_2 y_1$	00	01	11	10
00	0	0	1	0	
01	0	d	d	0	
11	0	d	d	1	
10	0	d	d	0	

$Y_2$

$w y_3$	$y_2 y_1$	00	01	11	10
00	0	0	0	1	
01	1	d	d	1	
11	0	d	d	0	
10	1	d	d	1	

$Y_1$

$w y_3$	$y_2 y_1$	00	01	11	10
00	1	1	0	1	
01	0	d	d	1	
11	1	d	d	0	
10	0	d	d	1	

$w$	$y_3$	$y_2$	$y_1$	$Y_3$	$Y_2$	$Y_1$
0	0	0	0	0	0	1
0	0	0	1	0	1	0
0	0	1	0	0	1	0
0	0	1	1	0	0	1
0	1	0	0	0	0	1
0	1	0	1	d	d	d
0	1	1	0	d	d	d
0	1	1	1	d	d	d
1	0	0	0	0	1	1
1	0	0	1	0	1	1
1	0	1	0	0	1	1
1	0	1	1	1	0	0
1	1	0	0	1	0	0
1	1	0	1	d	d	d
1	1	1	0	d	d	d
1	1	1	1	d	d	d

# K-Maps for $Y_3, Y_2, Y_1$

$Y_3$

$w y_3$	$y_2 y_1$	00	01	11	10
00	00	0	0	1	0
01	01	0	d	d	0
11	11	0	d	d	1
10	10	0	d	d	0

$Y_2$

$w y_3$	$y_2 y_1$	00	01	11	10
00	00	0	0	0	1
01	01	1	d	d	1
11	11	0	d	d	0
10	10	1	d	d	1

$Y_1$

$w y_3$	$y_2 y_1$	00	01	11	10
00	00	1	1	0	1
01	01	0	d	d	1
11	11	1	d	d	0
10	10	0	d	d	1

$w$	$y_3$	$y_2$	$y_1$	$Y_3$	$Y_2$	$Y_1$
0	0	0	0	0	0	1
0	0	0	1	0	1	0
0	0	1	0	0	1	0
0	0	1	1	0	0	1
0	1	0	0	0	0	1
0	1	0	1	d	d	d
0	1	1	0	d	d	d
0	1	1	1	d	d	d
1	0	0	0	0	1	1
1	0	0	1	0	1	1
1	0	1	0	0	1	1
1	0	1	1	1	0	0
1	1	0	0	1	0	0
1	1	0	1	d	d	d
1	1	1	0	d	d	d
1	1	1	1	d	d	d

# Expressions for $Y_3$ , $Y_2$ , $Y_1$

$Y_3$

$w y_3$	$y_2 y_1$	00	01	11	10
00	0	0	1	0	
01	0	d	d	0	
11	0	d	d	1	
10	0	d	d	0	

$Y_2$

$w y_3$	$y_2 y_1$	00	01	11	10
00	0	0	0	1	
01	1	d	d	1	
11	0	d	d	0	
10	1	d	d	1	

$Y_1$

$w y_3$	$y_2 y_1$	00	01	11	10
00	1	1	0	1	
01	0	d	d	1	
11	1	d	d	0	
10	0	d	d	1	

$w$	$y_3$	$y_2$	$y_1$	$Y_3$	$Y_2$	$Y_1$
0	0	0	0	0	0	1
0	0	0	1	0	1	0
0	0	1	0	0	1	0
0	0	1	1	0	0	1
0	1	0	0	0	0	1
0	1	0	1	d	d	d
0	1	1	0	d	d	d
0	1	1	1	d	d	d
1	0	0	0	0	1	1
1	0	0	1	0	1	1
1	0	1	0	0	1	1
1	0	1	1	0	1	1

$$Y_1 = w\bar{y}_1\bar{y}_3 + w\bar{y}_2\bar{y}_3 + \bar{w}y_1y_2 + \bar{w}\bar{y}_1\bar{y}_2$$

$$Y_2 = y_1\bar{y}_2 + \bar{y}_1y_2 + w\bar{y}_2\bar{y}_3$$

$$Y_3 = wy_3 + wy_1y_2$$

# Next State and Output Expressions

$$Y_1 = w\bar{y}_1\bar{y}_3 + w\bar{y}_2\bar{y}_3 + \bar{w}y_1y_2 + \bar{w}\bar{y}_1\bar{y}_2$$

$$Y_2 = y_1\bar{y}_2 + \bar{y}_1y_2 + w\bar{y}_2\bar{y}_3$$

$$Y_3 = wy_3 + wy_1y_2$$

$$z = y_3 + \bar{y}_1y_2$$

# An Improved State-Assigned Table

	Present state $y_3y_2y_1$	Next state		Output $z$
		$w = 0$	$w = 1$	
		$Y_3Y_2Y_1$	$Y_3Y_2Y_1$	
A	000	001	011	0
B	001	010	011	0
C	010	010	011	1
D	011	001	100	0
E	100	001	100	1

	Present state $y_3y_2y_1$	Next state		Output $z$
		$w = 0$	$w = 1$	
		$Y_3Y_2Y_1$	$Y_3Y_2Y_1$	
A	000	100	110	0
B	100	101	110	0
C	101	101	110	1
D	110	100	111	0
E	111	100	111	1



B,C, D, E – when  $y_3=1$

[ Figure 6.87 from the textbook ]

[ Figure 6.89 from the textbook ]

# An Improved State-Assigned Table

Present state	Next state		Output $z$
	$w = 0$	$w = 1$	
A	B	D	0
B	C	D	0
C	C	D	1
D	B	E	0
E	B	E	1

Present state	Next state		Output $z$
	$w = 0$	$w = 1$	
A	B	D	0
B	C	D	0
C	C	D	1
D	B	E	0
E	B	E	1

	Present state	Next state		Output $z$
		$w = 0$	$w = 1$	
	$y_3y_2y_1$	$Y_3Y_2Y_1$	$Y_3Y_2Y_1$	
A	000	001	011	0
B	001	010	011	0
C	010	010	011	1
D	011	001	100	0
E	100	001	100	1

	Present state	Next state		Output $z$
		$w = 0$	$w = 1$	
	$y_3y_2y_1$	$Y_3Y_2Y_1$	$Y_3Y_2Y_1$	
A	000	100	110	0
B	100	101	110	0
C	101	101	110	1
D	110	100	111	0
E	111	100	111	1



B, C, D, E – when  $y_3=1$

[ Figure 6.87 from the textbook ]

[ Figure 6.89 from the textbook ]

# An Improved State-Assigned Table

	Present state $y_3y_2y_1$	Next state		Output $z$
		$w = 0$	$w = 1$	
		$Y_3Y_2Y_1$	$Y_3Y_2Y_1$	
A	000	100	110	0
B	100	101	110	0
C	101	101	110	1
D	110	100	111	0
E	111	100	111	1

# An Improved State-Assigned Table

	Present state $y_3y_2y_1$	Next state		Output $z$
		$w = 0$	$w = 1$	
		$Y_3Y_2Y_1$	$Y_3Y_2Y_1$	
A	000	100	110	0
B	100	101	110	0
C	101	101	110	1
D	110	100	111	0
E	111	100	111	1

cut here



# An Improved State-Assigned Table

	Present state $y_3y_2y_1$	Next state		Output $z$
		$w = 0$	$w = 1$	
		$Y_3Y_2Y_1$	$Y_3Y_2Y_1$	
A	000	100	110	0
	001	ddd	ddd	d
	010	ddd	ddd	d
	011	ddd	ddd	d
B	100	101	110	0
C	101	101	110	1
D	110	100	111	0
E	111	100	111	1

# Truth Table for the Output z

	Present state $y_3y_2y_1$	Next state		Output $z$
		$w = 0$	$w = 1$	
		$Y_3Y_2Y_1$	$Y_3Y_2Y_1$	
A	000	100	110	0
	001	<u>ddd</u>	<u>ddd</u>	d
	010	<u>ddd</u>	<u>ddd</u>	d
	011	<u>ddd</u>	<u>ddd</u>	d
B	100	101	110	0
C	101	101	110	1
D	110	100	111	0
E	111	100	111	1

$y_3$	$y_2$	$y_1$	$z$
0	0	0	0
0	0	1	d
0	1	0	d
0	1	1	d
1	0	0	0
1	0	1	1
1	1	0	0
1	1	1	1

# Expression for the Output z

	Present state $y_3y_2y_1$	Next state		Output $z$
		$w = 0$	$w = 1$	
		$Y_3Y_2Y_1$	$Y_3Y_2Y_1$	
A	000	100	110	0
	<b>001</b>	<u>ddd</u>	<u>ddd</u>	<b>d</b>
	<b>010</b>	<u>ddd</u>	<u>ddd</u>	<b>d</b>
	<b>011</b>	<u>ddd</u>	<u>ddd</u>	<b>d</b>
B	100	101	110	0
C	101	101	110	1
D	110	100	111	0
E	111	100	111	1

$z$	$y_3y_2$	00	01	11	10
0		0	d	0	0
1		d	d	1	1

$y_3$	$y_2$	$y_1$	$z$
0	0	0	0
0	0	1	d
0	1	0	d
0	1	1	d
1	0	0	0
1	0	1	1
1	1	0	0
1	1	1	1

# Truth Table for $Y_3$

	Present state $y_3y_2y_1$	Next state		Output $z$
		$w = 0$	$w = 1$	
		$Y_3Y_2Y_1$	$Y_3Y_2Y_1$	
A	000	100	110	0
	001	ddd	ddd	d
	010	ddd	ddd	d
	011	ddd	ddd	d
B	100	101	110	0
C	101	101	110	1
D	110	100	111	0
E	111	100	111	1

$w$	$y_3$	$y_2$	$y_1$	$Y_3$	$Y_2$	$Y_1$
0	0	0	0	1		
0	0	0	1	d		
0	0	1	0	d		
0	0	1	1	d		
0	1	0	0	1		
0	1	0	1	1		
0	1	1	0	1		
0	1	1	1	1		
1	0	0	0	1		
1	0	0	1	d		
1	0	1	0	d		
1	0	1	1	d		
1	1	0	0	1		
1	1	0	1	1		
1	1	1	0	1		
1	1	1	1	1		

# Truth Table for $Y_2$

	Present state $y_3y_2y_1$	Next state		Output $z$
		$w = 0$	$w = 1$	
		$Y_3Y_2Y_1$	$Y_3Y_2Y_1$	
A	000	100	110	0
	001	ddd	ddd	d
	010	ddd	ddd	d
	011	ddd	ddd	d
B	100	101	110	0
C	101	101	110	1
D	110	100	111	0
E	111	100	111	1

$w$	$y_3$	$y_2$	$y_1$	$Y_3$	$Y_2$	$Y_1$
0	0	0	0	1	0	
0	0	0	1	d	d	
0	0	1	0	d	d	
0	0	1	1	d	d	
0	1	0	0	1	0	
0	1	0	1	1	0	
0	1	1	0	1	0	
0	1	1	1	1	0	
1	0	0	0	1	1	
1	0	0	1	d	d	
1	0	1	0	d	d	
1	0	1	1	d	d	
1	1	0	0	1	1	
1	1	0	1	1	1	
1	1	1	0	1	1	
1	1	1	1	1	1	

# Truth Table for $Y_1$

	Present state $y_3y_2y_1$	Next state		Output $z$
		$w = 0$	$w = 1$	
		$Y_3Y_2Y_1$	$Y_3Y_2Y_1$	
A	000	100	110	0
	001	ddd	ddd	d
	010	ddd	ddd	d
	011	ddd	ddd	d
B	100	101	110	0
C	101	101	110	1
D	110	100	111	0
E	111	100	111	1

$w$	$y_3$	$y_2$	$y_1$	$Y_3$	$Y_2$	$Y_1$
0	0	0	0	1	0	0
0	0	0	1	d	d	d
0	0	1	0	d	d	d
0	0	1	1	d	d	d
0	1	0	0	1	0	1
0	1	0	1	1	0	1
0	1	1	0	1	0	0
0	1	1	1	1	0	0
1	0	0	0	1	1	0
1	0	0	1	d	d	d
1	0	1	0	d	d	d
1	0	1	1	d	d	d
1	1	0	0	1	1	0
1	1	0	1	1	1	0
1	1	1	0	1	1	1
1	1	1	1	1	1	1

# K-Maps for $Y_3, Y_2, Y_1$

$Y_3$

$w y_3$	$y_2 y_1$	00	01	11	10
00	00	1	1	1	1
01	00	d	1	1	d
11	00	d	1	1	d
10	00	d	1	1	d

$Y_2$

$w y_3$	$y_2 y_1$	00	01	11	10
00	00	0	0	1	1
01	00	d	0	1	d
11	00	d	0	1	d
10	00	d	0	1	d

$Y_1$

$w y_3$	$y_2 y_1$	00	01	11	10
00	00	0	1	0	0
01	00	d	1	0	d
11	00	d	0	1	d
10	00	d	0	1	d

$w$	$y_3$	$y_2$	$y_1$	$Y_3$	$Y_2$	$Y_1$
0	0	0	0	1	0	0
0	0	0	1	d	d	d
0	0	1	0	d	d	d
0	0	1	1	d	d	d
0	1	0	0	1	0	1
0	1	0	1	1	0	1
0	1	1	0	1	0	0
0	1	1	1	1	0	0
1	0	0	0	1	1	0
1	0	0	1	d	d	d
1	0	1	0	d	d	d
1	0	1	1	d	d	d
1	1	0	0	1	1	0
1	1	0	1	1	1	0
1	1	1	0	1	1	1
1	1	1	1	1	1	1

# K-Maps for $Y_3, Y_2, Y_1$

$Y_3$

$w y_3$	$y_2 y_1$	00	01	11	10
00	00	1	1	1	1
01	01	d	1	1	d
11	11	d	1	1	d
10	10	d	1	1	d

$Y_2$

$w y_3$	$y_2 y_1$	00	01	11	10
00	00	0	0	1	1
01	01	d	0	1	d
11	11	d	0	1	d
10	10	d	0	1	d

$Y_1$

$w y_3$	$y_2 y_1$	00	01	11	10
00	00	0	1	0	0
01	01	d	1	0	d
11	11	d	0	1	d
10	10	d	0	1	d

$w$	$y_3$	$y_2$	$y_1$	$Y_3$	$Y_2$	$Y_1$
0	0	0	0	1	0	0
0	0	0	1	d	d	d
0	0	1	0	d	d	d
0	0	1	1	d	d	d
0	1	0	0	1	0	1
0	1	0	1	1	0	1
0	1	1	0	1	0	0
0	1	1	1	1	0	0
1	0	0	0	1	1	0
1	0	0	1	d	d	d
1	0	1	0	d	d	d
1	0	1	1	d	d	d
1	1	0	0	1	1	0
1	1	0	1	1	1	0
1	1	1	0	1	1	1
1	1	1	1	1	1	1



# K-Maps for $Y_3, Y_2, Y_1$

$Y_3$

$w y_3$	$y_2 y_1$	00	01	11	10
00	00	1	1	1	1
01	01	d	1	1	d
11	11	d	1	1	d
10	10	d	1	1	d

$Y_2$

$w y_3$	$y_2 y_1$	00	01	11	10
00	00	0	0	1	1
01	01	d	0	1	d
11	11	d	0	1	d
10	10	d	0	1	d

$Y_1$

$w y_3$	$y_2 y_1$	00	01	11	10
00	00	0	1	0	0
01	01	d	1	0	d
11	11	d	0	1	d
10	10	d	0	1	d

$$Y_1 = wy_2 + \bar{w}y_3\bar{y}_2$$

$$Y_2 = w$$

$$Y_3 = 1$$

$w$	$y_3$	$y_2$	$y_1$	$Y_3$	$Y_2$	$Y_1$
0	0	0	0	1	0	0
0	0	0	1	d	d	d
0	0	1	0	d	d	d
0	0	1	1	d	d	d
0	1	0	0	1	0	1
0	1	0	1	1	0	1
0	1	1	0	1	0	0
0	1	1	1	1	0	0
1	0	0	0	1	1	0
1	0	0	1	d	d	d
1	0	1	0	d	d	d
1	0	1	1	d	d	d
1	1	0	0	1	1	0
1	1	0	1	1	1	0
1	1	1	0	1	1	1
1	1	1	1	1	1	1

# An Improved State-Assigned Table

	Present state $y_3y_2y_1$	Next state		Output $z$
		$w = 0$	$w = 1$	
		$Y_3Y_2Y_1$	$Y_3Y_2Y_1$	
A	000	100	110	0
B	100	101	110	0
C	101	101	110	1
D	110	100	111	0
E	111	100	111	1

$$Y_1 = wy_2 + \bar{w}y_3\bar{y}_2$$

$$Y_2 = w$$

$$Y_3 = 1$$

$$z = y_1$$

# An Improved State-Assigned Table

	Present state $y_3y_2y_1$	Next state		Output $z$
		$w = 0$	$w = 1$	
		$Y_3Y_2Y_1$	$Y_3Y_2Y_1$	
A	000	100	110	0
B	100	101	110	0
C	101	101	110	1
D	110	100	111	0
E	111	100	111	1

$$Y_1 = wy_2 + \bar{w}y_3\bar{y}_2$$

$$Y_2 = w$$

~~$$Y_3 = 1$$~~

$$z = y_1$$

# The Circuit Diagram

$$Y_1 = w y_2 + \bar{w} y_3 \bar{y}_2$$

$$Y_2 = w$$

$$Y_3 = 1$$

$$z = y_1$$

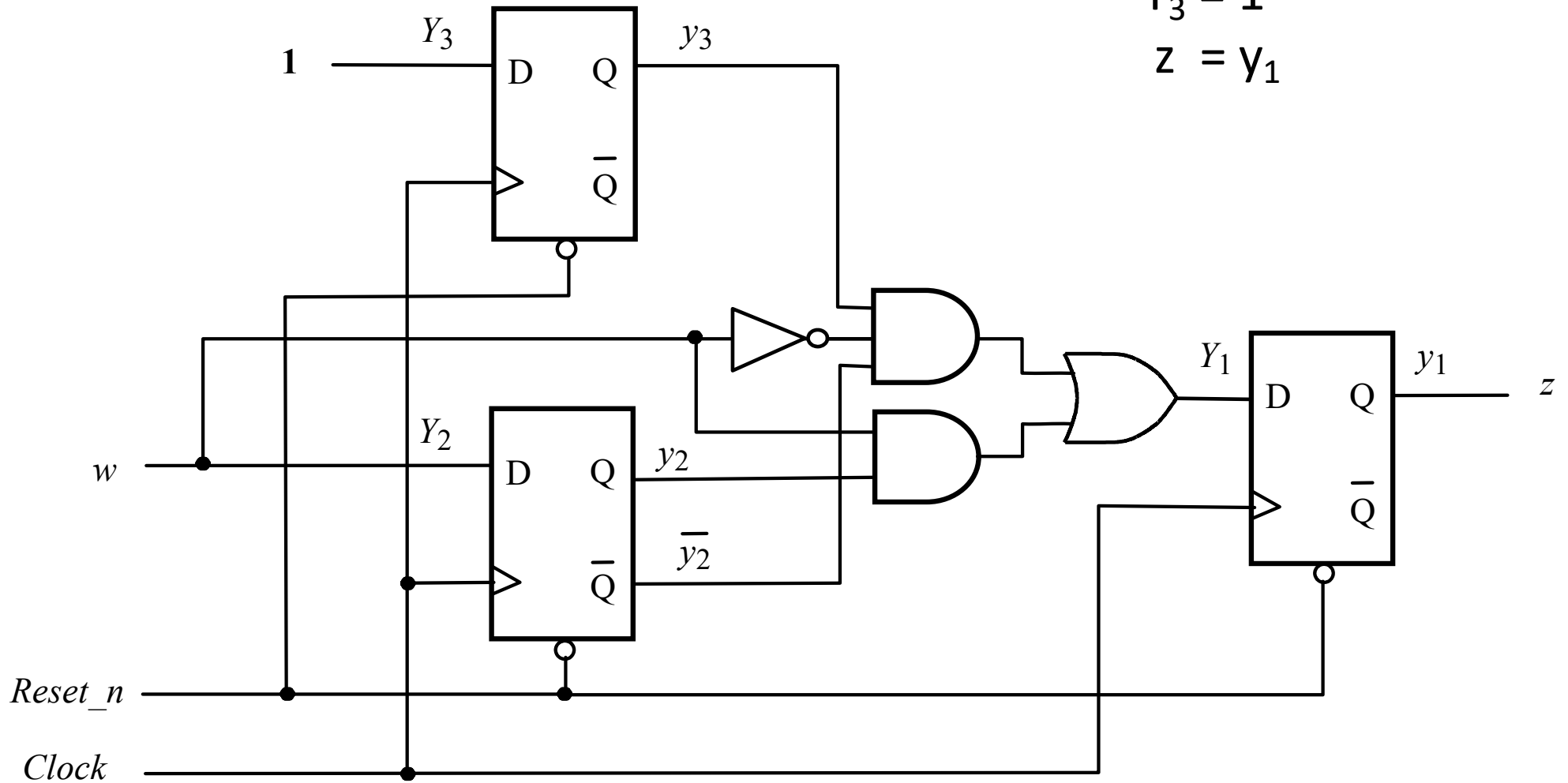

# The Circuit Diagram

this is always 1,  
except when reset\_n=0

$$Y_1 = w y_2 + \bar{w} y_3 \bar{y}_2$$
$$Y_2 = w$$
$$Y_3 = 1$$
$$z = y_1$$

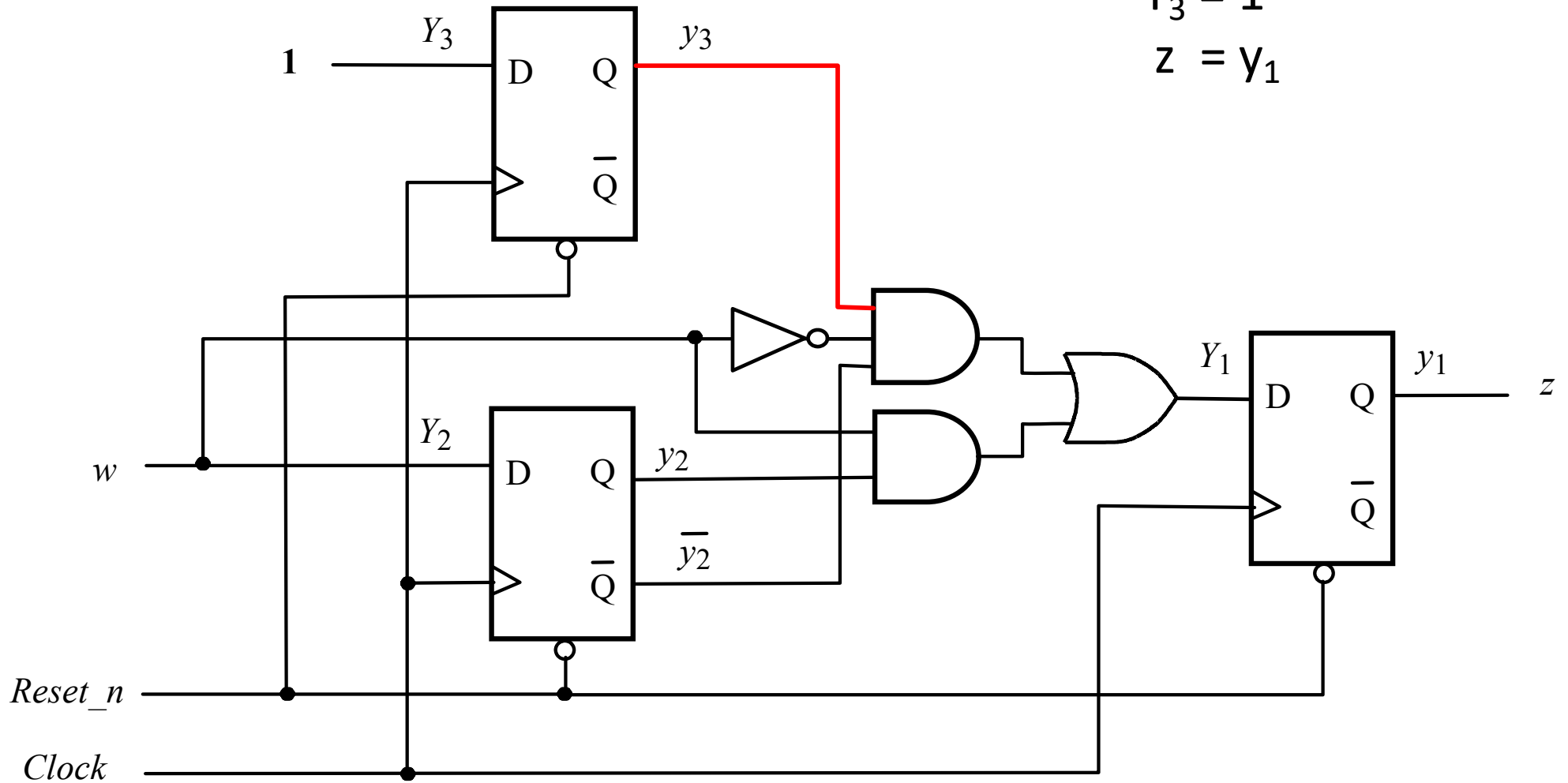

# The Circuit Diagram

$$Y_1 = w y_2 + \bar{w} y_3 \bar{y}_2$$

$$Y_2 = w$$

~~$$Y_3 = 1$$~~

$$z = y_1$$

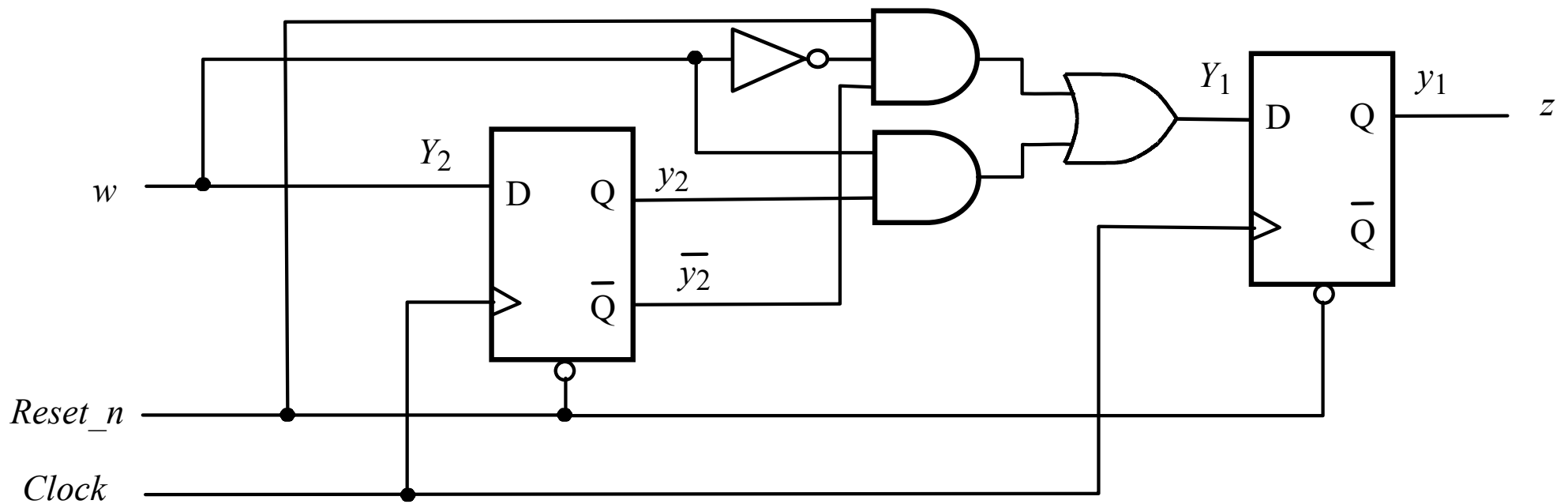

# State Diagram

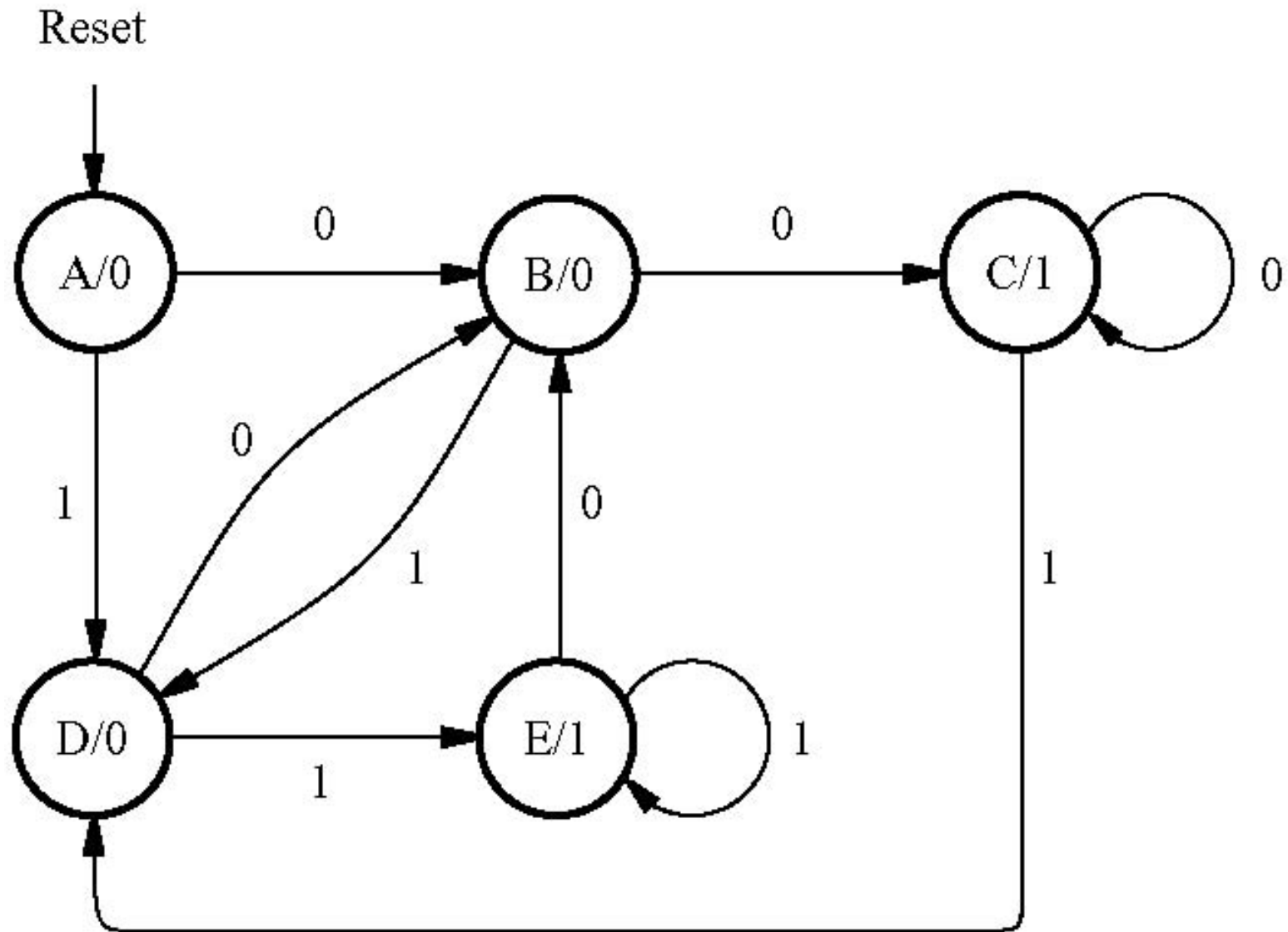

[ Figure 6.86 from the textbook ]

# **Example 6.13**



# Goal

- Design an FSM that detects if the previous two values of the input  $w$  were equal to 00 or 11.
- **But do this with two different FSMs.** The first one detects two consecutive 1's. The second one detects two consecutive 0's.
- If either condition (i.e., output of FSM) is true then the output  $z$  should be set to 1; otherwise to 0.

## **Example 6.13**

**(Construct the first FSM)**

# FSM to detect two consecutive 1's (this was the first example in Chapter 6)

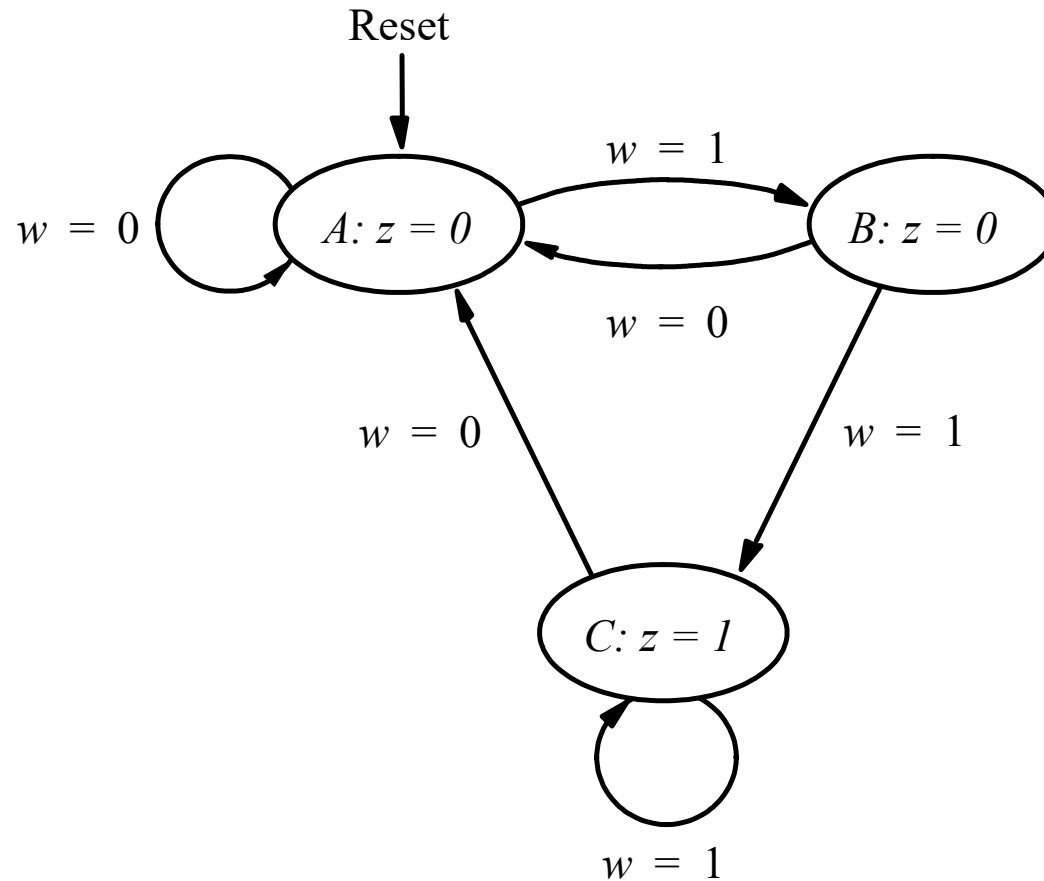

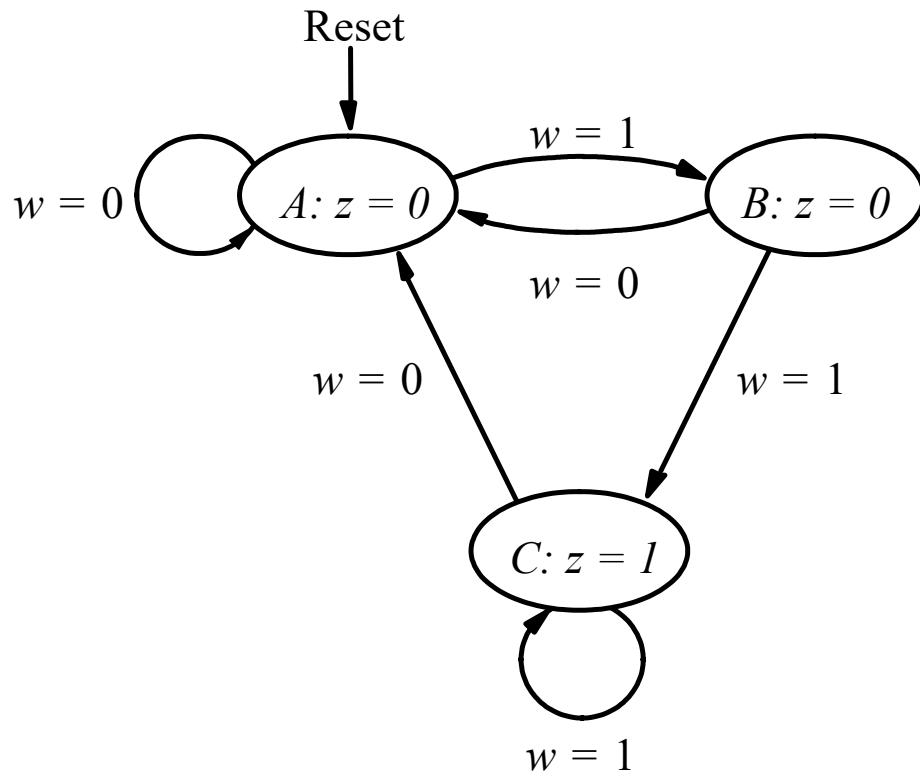

Present state	Next state		Output $z$
	$w = 0$	$w = 1$	
A			
B			
C			

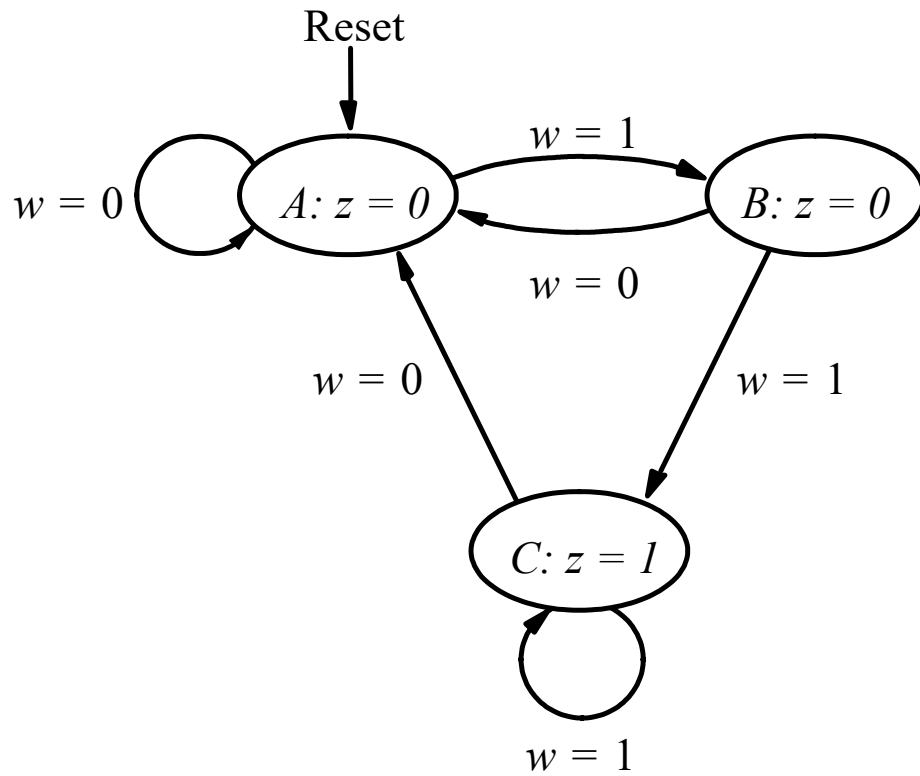

Present state	Next state		Output $z$
	$w = 0$	$w = 1$	
A	A	B	0
B	A	C	0
C	A	C	1

[ Figure 6.4 from the textbook ]

# A Better State Encoding

Present state	Next state		Output $z$
	$w = 0$	$w = 1$	
A	A	B	0
B	A	C	0
C	A	C	1

Suppose we encoded our states another way:

A  $\sim$  00

B  $\sim$  01

C  $\sim$  11

# A Better State Encoding

Present state	Next state		Output $z$
	$w = 0$	$w = 1$	
A	A	B	0
B	A	C	0
C	A	C	1

Present state	Next state		Output $z$
	$w = 0$	$w = 1$	

A ~ 00

B ~ 01

C ~ 11

# A Better State Encoding

Present state	Next state		Output $z$
	$w = 0$	$w = 1$	
A	A	B	0
B	A	C	0
C	A	C	1

	Present state	Next state		Output $z$
		$w = 0$	$w = 1$	
	$y_2y_1$	$Y_2Y_1$	$Y_2Y_1$	
A	00	00	01	0
B	01	00	11	0
C	11	00	11	1
	10	$dd$	$dd$	$d$



# Let's Derive the Logic Expressions

	Present state	Next state		Output $z$
		$w = 0$	$w = 1$	
	$y_2y_1$	$Y_2Y_1$	$Y_2Y_1$	
A	00	00	01	0
B	01	00	11	0
C	11	00	11	1
	10	<i>dd</i>	<i>dd</i>	<i>d</i>

# Let's Derive the Logic Expressions

Warning:  
This table does not enumerate  $y_2y_1$ , in the standard way, so be careful when filling out the K-Map.

	Present state	Next state		Output
		$w = 0$	$w = 1$	
	$y_2y_1$	$Y_2Y_1$	$Y_2Y_1$	$z$
A	00	00	01	0
B	01	00	11	0
C	11	00	11	1
	10	<i>dd</i>	<i>dd</i>	<i>d</i>

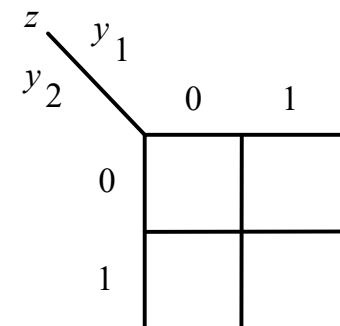
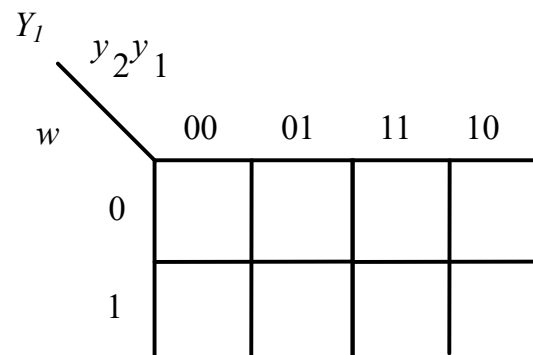
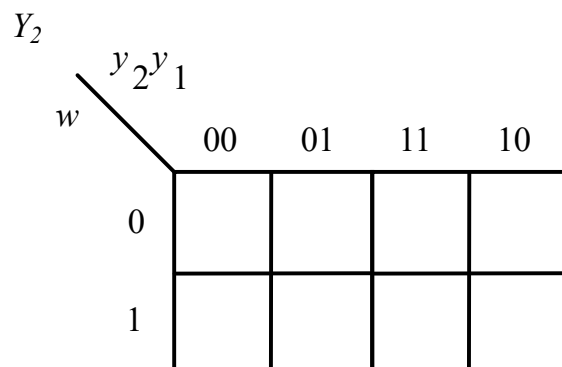

# Let's Derive the Logic Expressions

Warning:  
This table does not enumerate  $y_2y_1$ , in the standard way, so be careful when filling out the K-Map.

	Present state $y_2y_1$	Next state		Output $z$
		$w = 0$	$w = 1$	
		$Y_2Y_1$	$Y_2Y_1$	
A	00	00	01	0
B	01	00	11	0
C	11	00	11	1
	10	<i>dd</i>	<i>dd</i>	<i>d</i>

		$y_2y_1$			
		00	01	11	10
$w$	0	0	0	0	d
	1	0	1	1	d

$$Y_2(w, y_2, y_1) = wy_1$$

		$y_2y_1$			
		00	01	11	10
$w$	0	0	0	0	d
	1	1	1	1	d

$$Y_1(w, y_2, y_1) = w$$

		$y_1$	
		0	1
$w$	0	0	0
	1	d	1

$$z(y_2, y_1) = y_2$$

## Original State Encodings

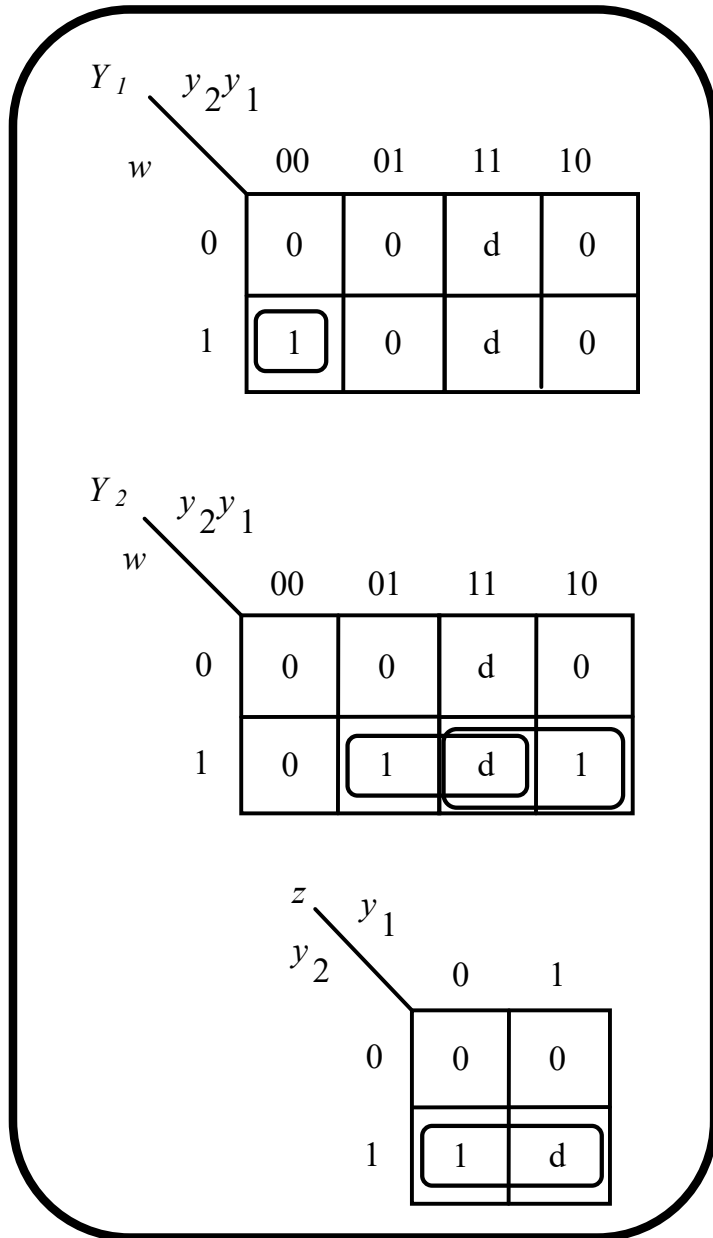

## New State Encodings

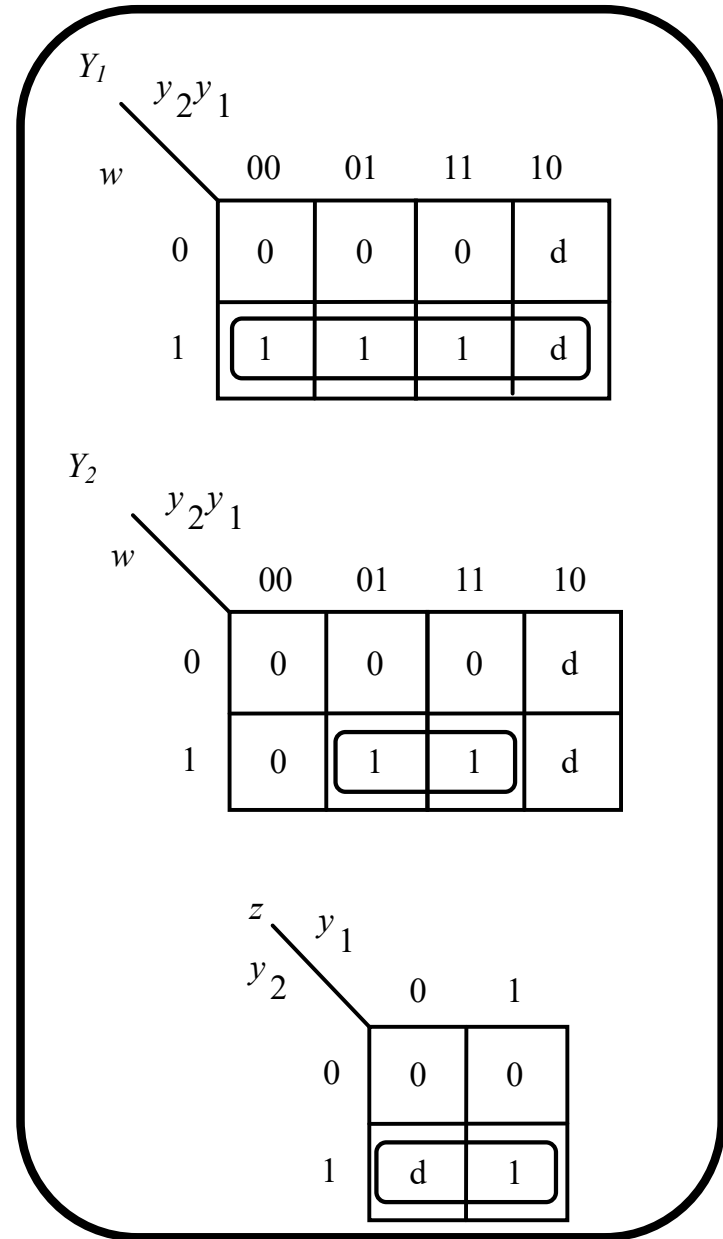

# The Circuit Diagram

$$Y_1(w, y_2, y_1) = w$$

$$Y_2(w, y_2, y_1) = wy_1$$

$$z(y_2, y_1) = y_2$$

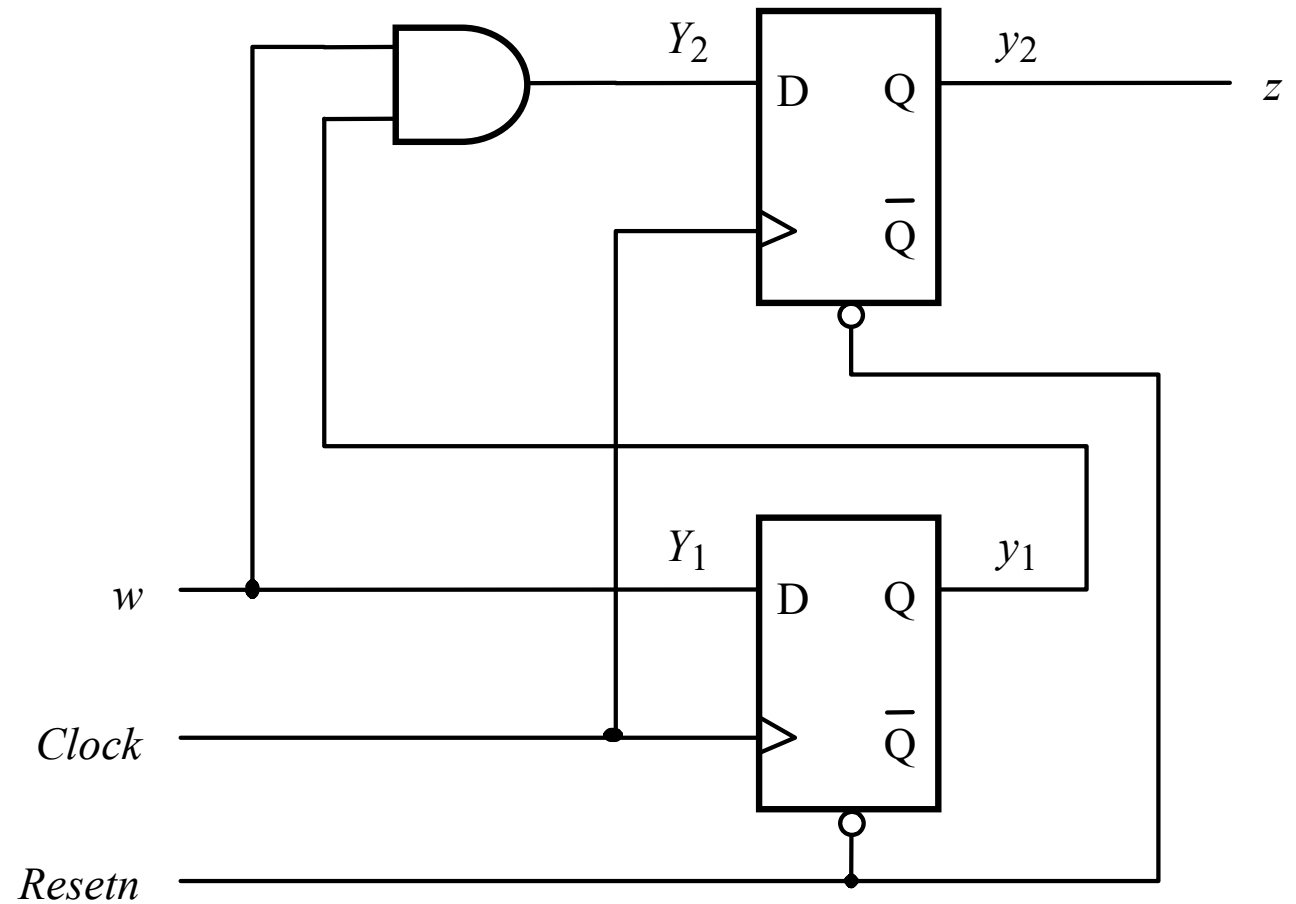

[ Figure 6.17 from the textbook ]

## **Example 6.13**

**(Construct the second FSM)**

# FSM to detect two consecutive 0's

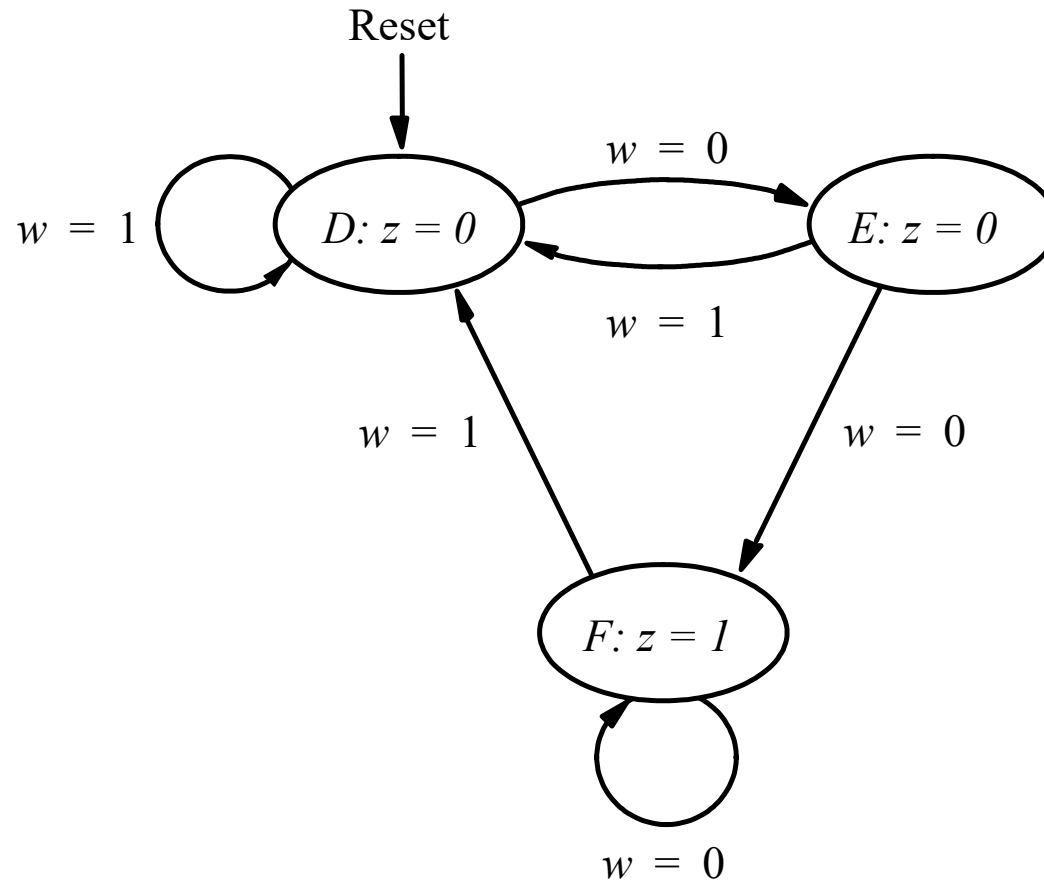

This is similar to the previous one. Just invert the  $w$ 's and relabel the states to D,E,F.

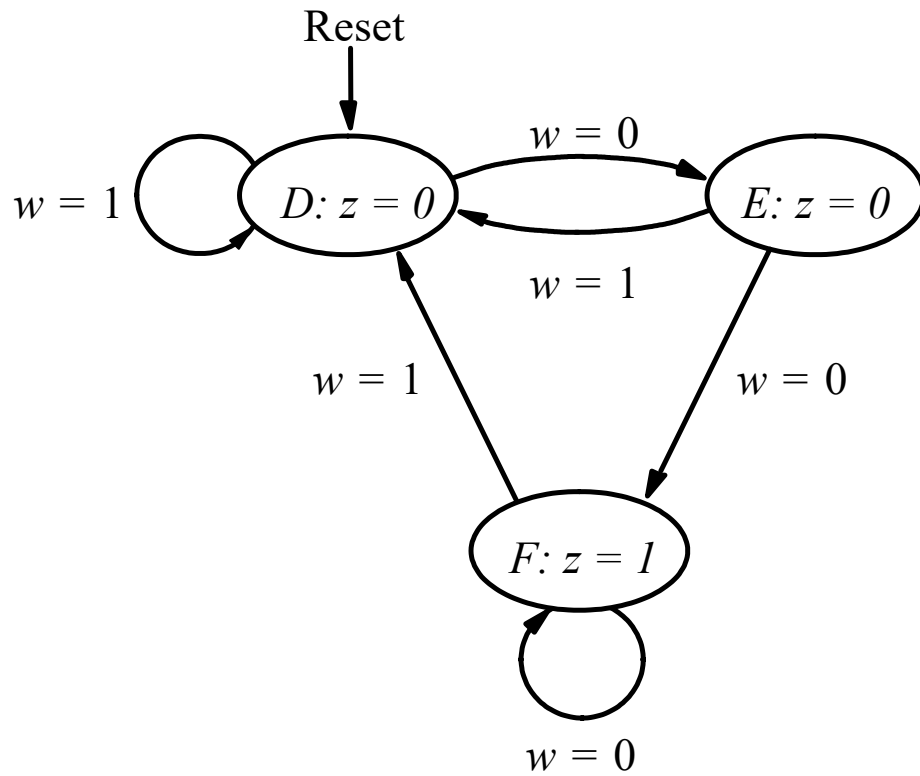

Present state	Next state		Output $z$
	$w = 0$	$w = 1$	
D			
E			
F			



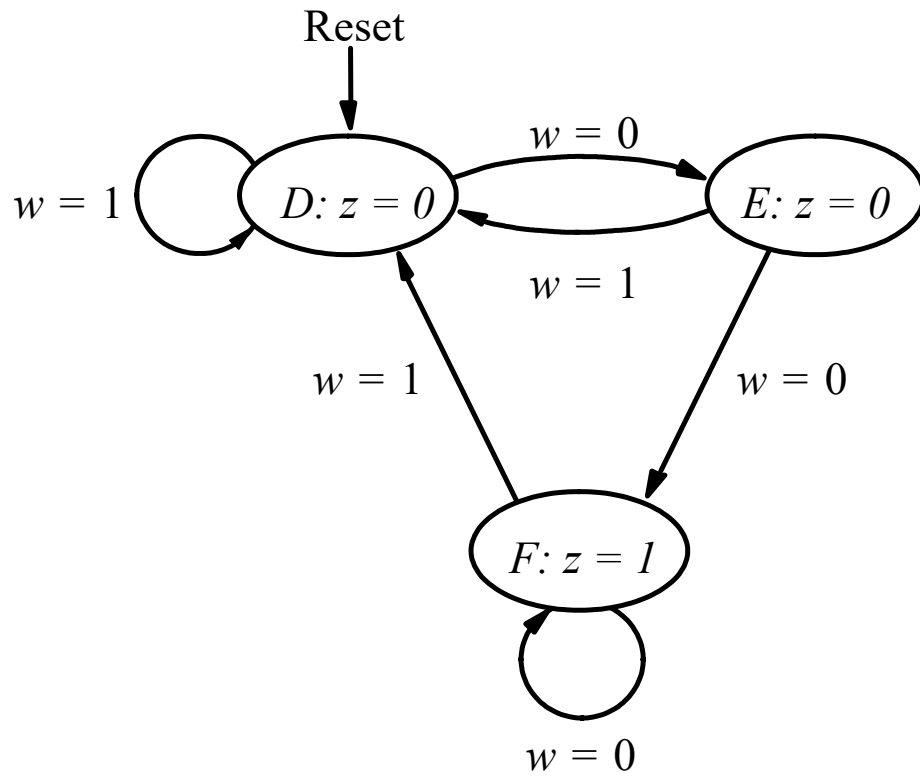

Present state	Next state		Output $z$
	$w = 0$	$w = 1$	
D	E	D	0
E	F	D	0
F	F	D	1

# FSM that detects a sequence of two zeros

Present state	Next state		Output $z_{zeros}$
	$w = 0$	$w = 1$	
D	E	D	0
E	F	D	0
F	F	D	1

(a) State table

	Present state	Next state		Output $z_{zeros}$
		$w = 0$	$w = 1$	
	$y_4y_3$	$Y_4Y_3$	$Y_4Y_3$	
D	00	01	00	0
E	01	11	00	0
F	11	11	00	1
	10	$dd$	$dd$	$d$

# FSM that detects a sequence of two zeros

Present state	Next state		Output $z_{zeros}$
	$w = 0$	$w = 1$	
D	E	D	0
E	F	D	0
F	F	D	1

Only these two columns are swapped relative to the first FSM. And the states have different names now.

(a) State table

	Present state	Next state		Output $z_{zeros}$
		$w = 0$	$w = 1$	
	$y_4y_3$	$Y_4Y_3$	$Y_4Y_3$	
D	00	01	00	0
E	01	11	00	0
F	11	11	00	1
	10	$dd$	$dd$	$d$

Only these two columns are swapped relative to the first FSM.

# Let's Derive the Logic Expressions

	Present state	Next state		Output
		$w = 0$	$w = 1$	
	$y_4y_3$	$Y_4Y_3$	$Y_4Y_3$	$z$
D	00	01	00	0
E	01	11	00	0
F	11	11	00	1
	10	<i>dd</i>	<i>dd</i>	<i>d</i>

# Let's Derive the Logic Expressions

	Present state $y_4y_3$	Next state		Output $z$
		$w = 0$	$w = 1$	
		$Y_4Y_3$	$Y_4Y_3$	
D	00	01	00	0
E	01	11	00	0
F	11	11	00	1
	10	<i>dd</i>	<i>dd</i>	<i>d</i>

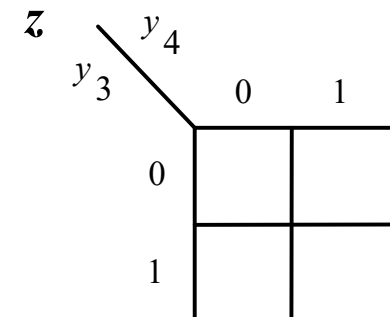
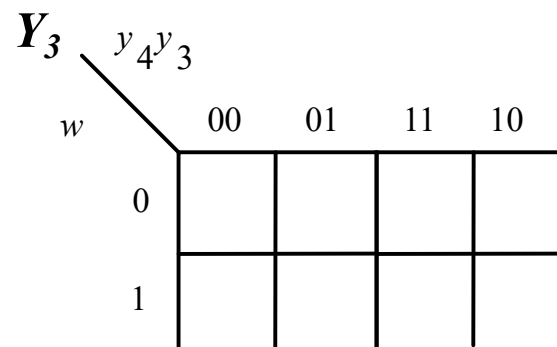
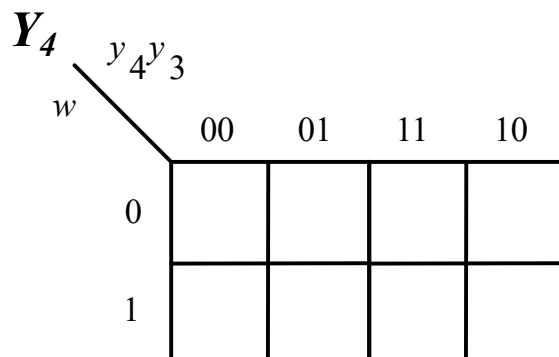

# Let's Derive the Logic Expressions

	Present state	Next state		Output
		$w = 0$	$w = 1$	
	$y_4y_3$	$Y_4Y_3$	$Y_4Y_3$	$z$
D	00	01	00	0
E	01	11	00	0
F	11	11	00	1
	10	<i>dd</i>	<i>dd</i>	<i>d</i>

$Y_4$

$w$	$y_4y_3$			
	00	01	11	10
0	0	1	1	d
1	0	0	0	d

$$Y_4(w, y_4, y_3) = \bar{w} y_3$$

$Y_3$

$w$	$y_4y_3$			
	00	01	11	10
0	1	1	1	d
1	0	0	0	d

$$Y_3(w, y_4, y_3) = \bar{w}$$

$z$

$y_4$	$y_3$	
	0	1
0	0	0
1	d	1

$$z(y_4, y_3) = y_4$$

# The Circuit Diagram

$$Y_3(w, y_4, y_3) = \bar{w}$$

$$Y_4(w, y_4, y_3) = \bar{w} y_3$$

$$z(y_2, y_1) = y_4$$

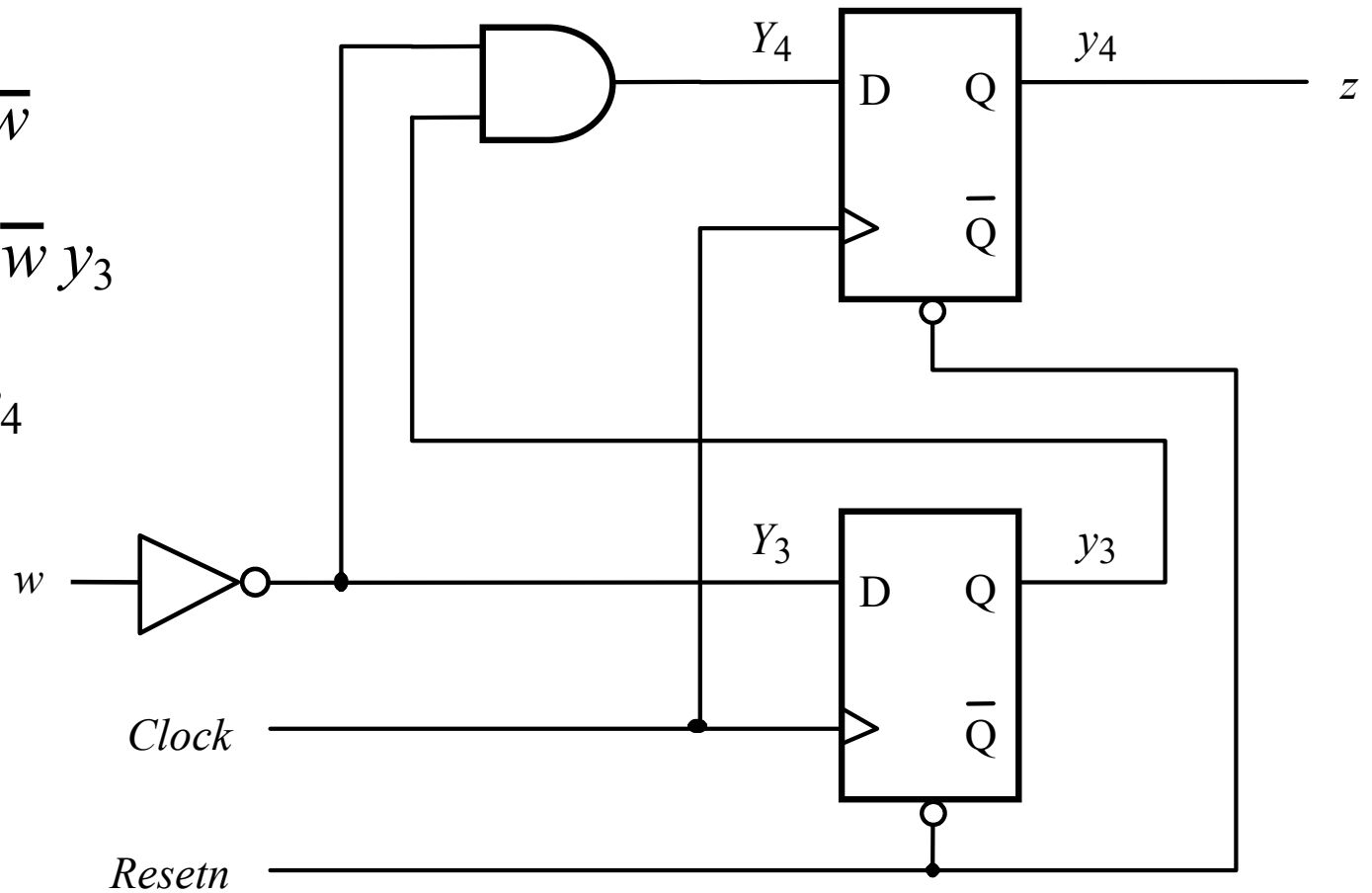

## **Example 6.13**

**(Combine the two FSMs)**



# The Two FSMs

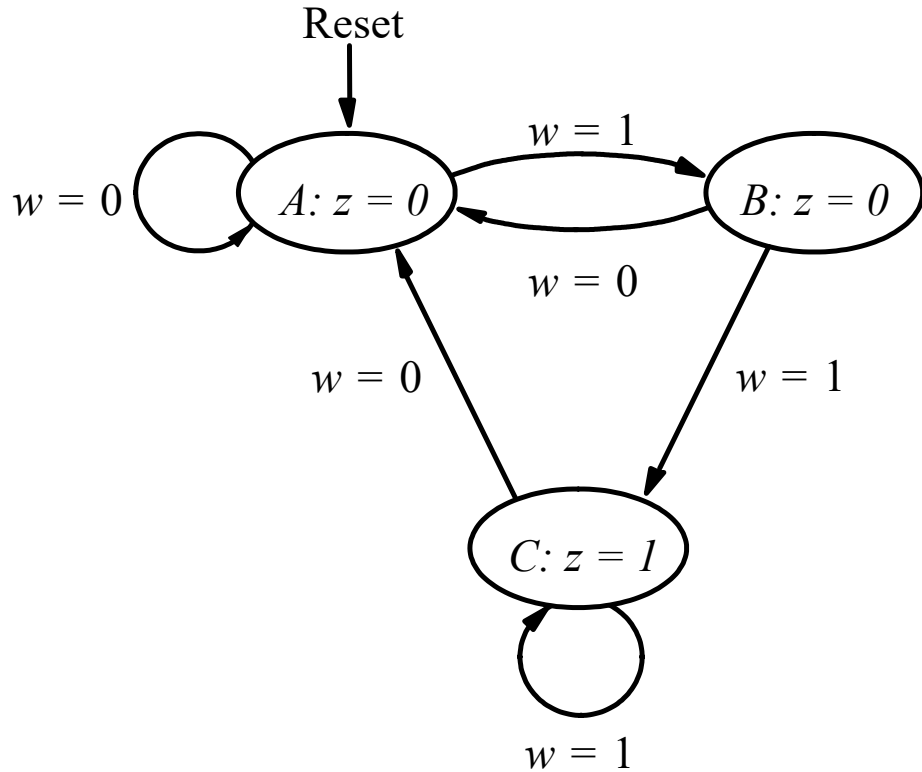

**Detect two consecutive 1's**

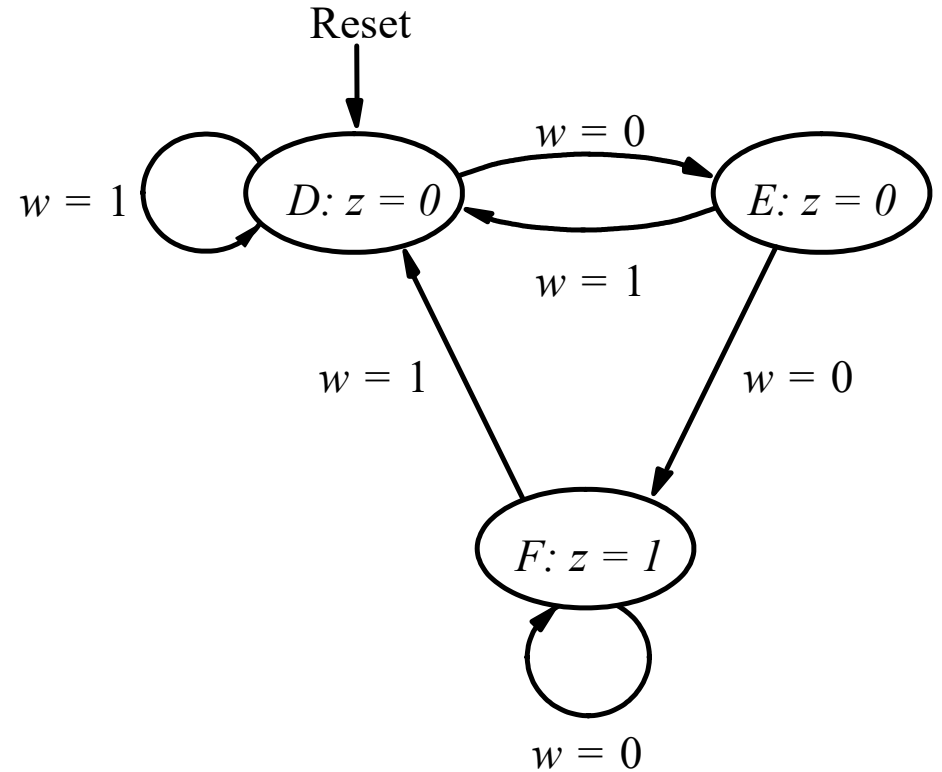

**Detect two consecutive 0's**

# The Two Circuit Diagrams

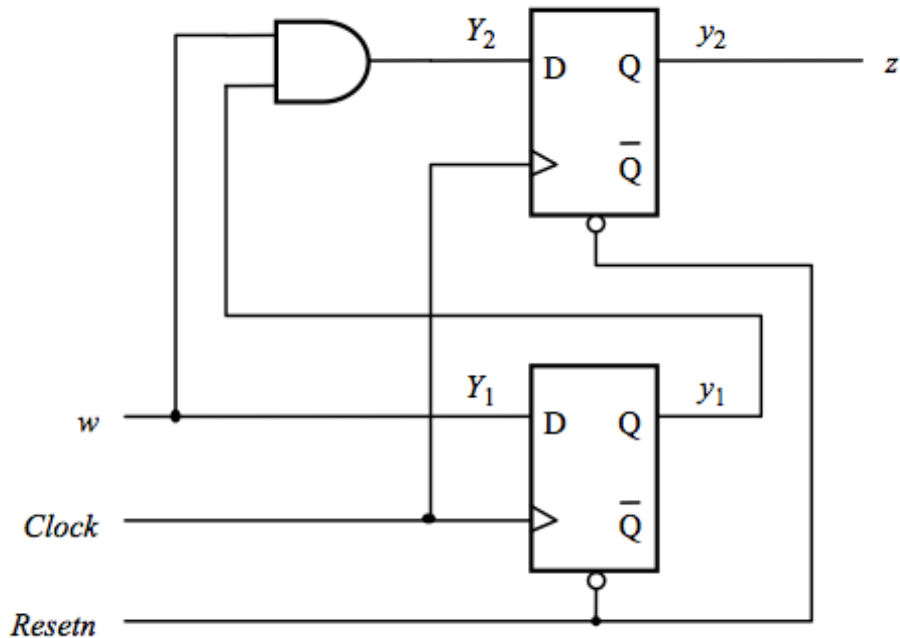

**Detect two consecutive 1's**

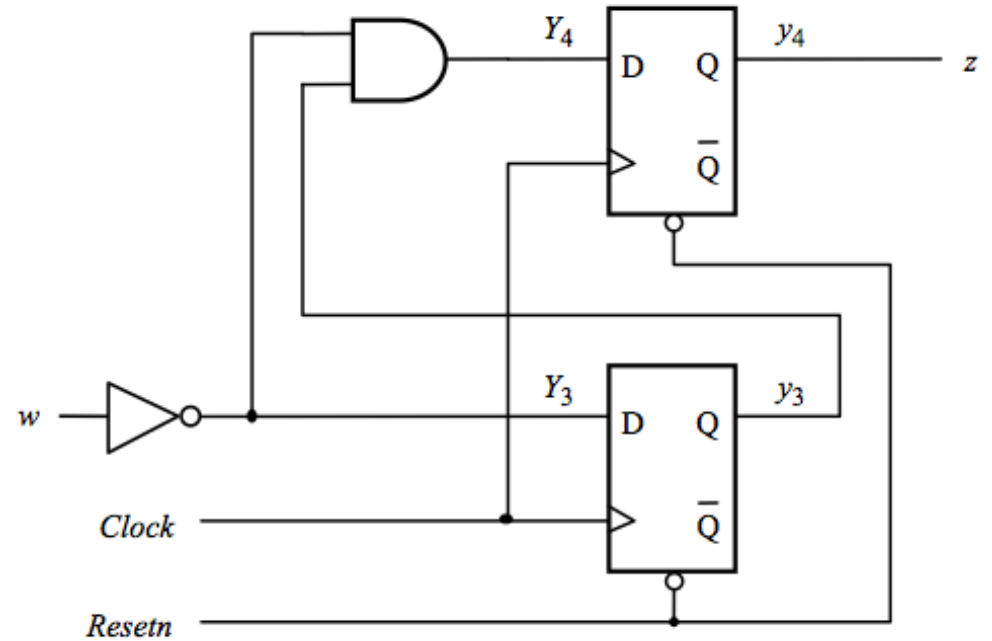

**Detect two consecutive 0's**

# The Combined Circuit Diagram

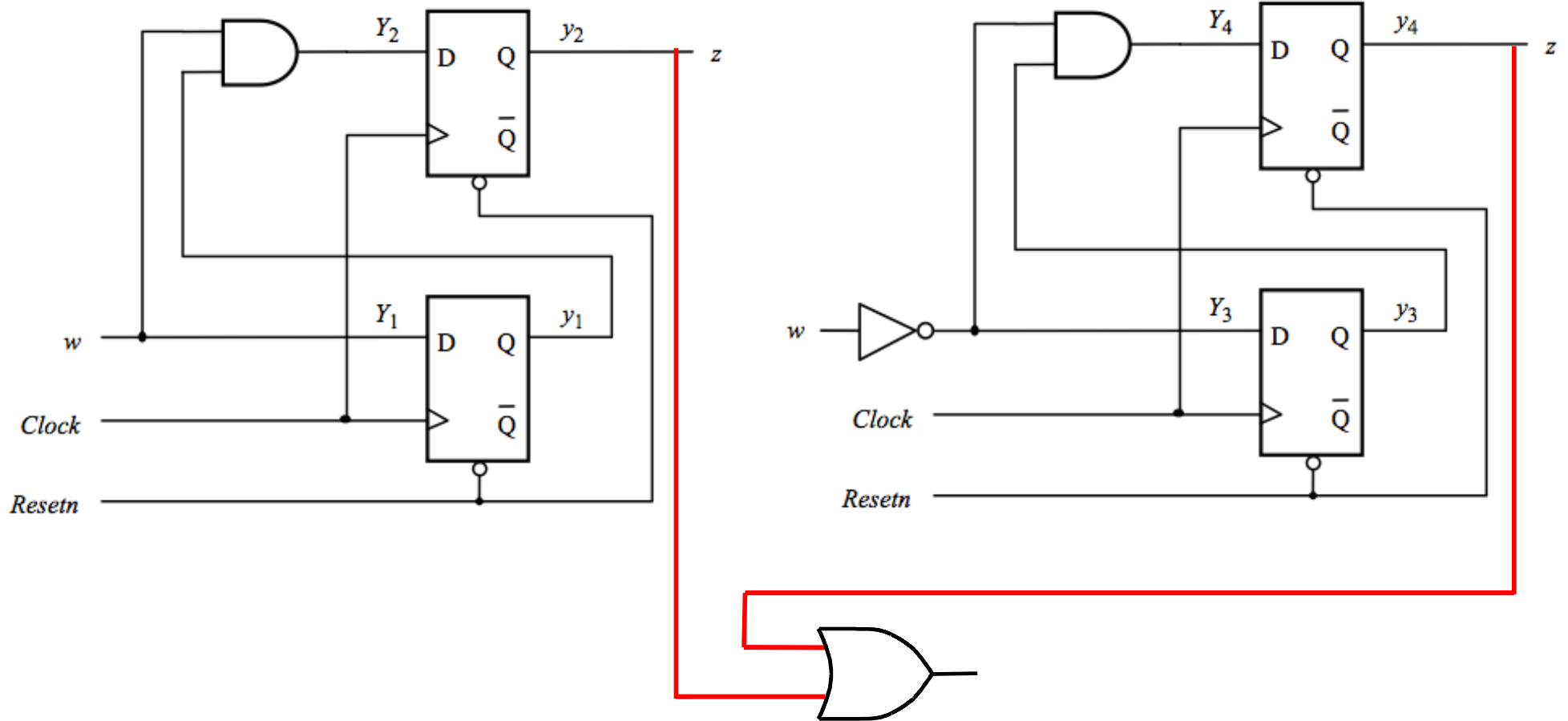

**Detect two consecutive 1's or two consecutive 0's**

## **Example 6.14**

# Goal

- Design an FSM that detects if the previous two values of the input  $w$  were equal to 00 or 11.
- If either condition is true then the output  $z$  should be set to 1; otherwise to 0.
- Implement this as a **Mealy-type machine**

# State Diagram

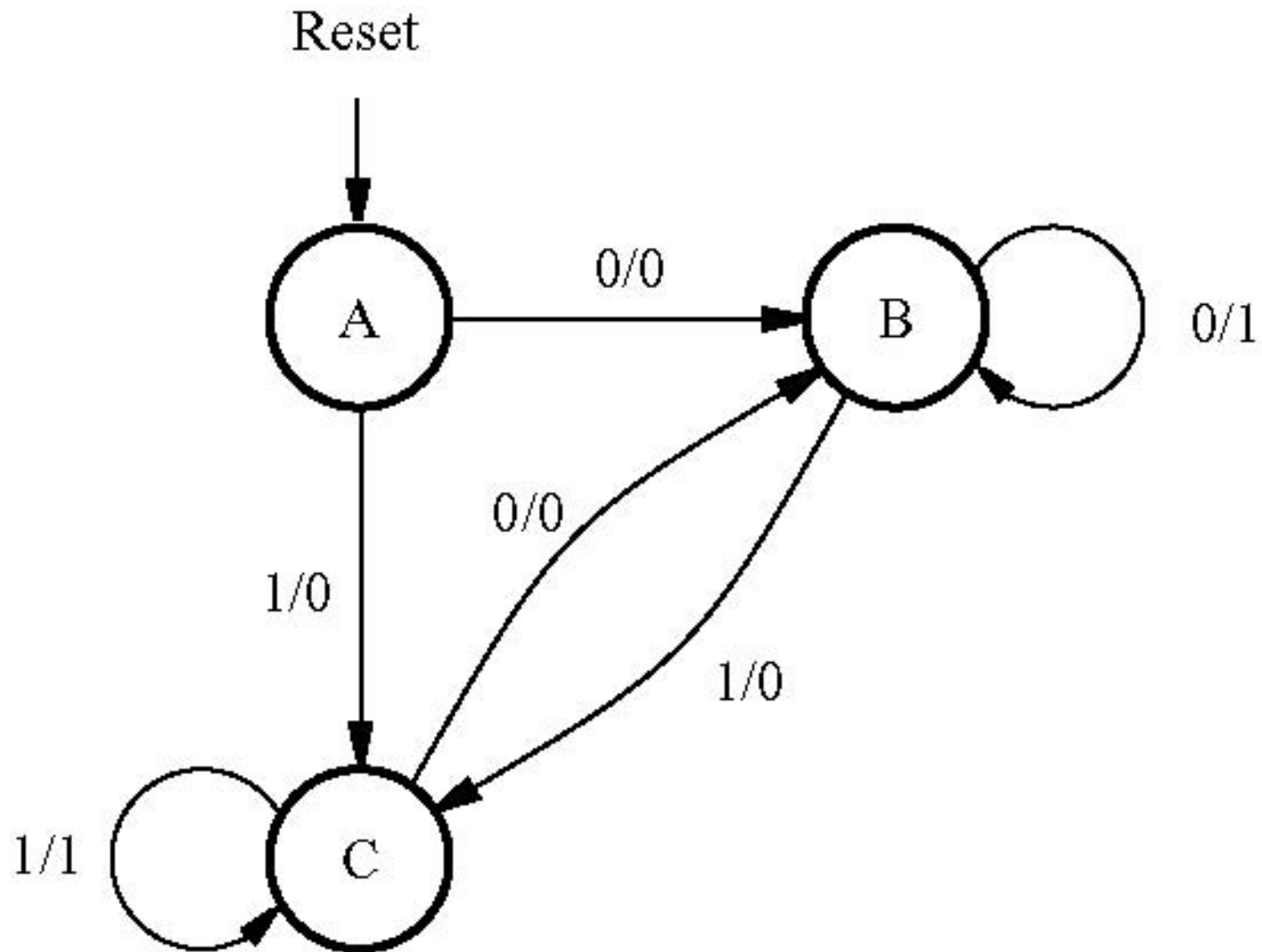

# Building the State Table

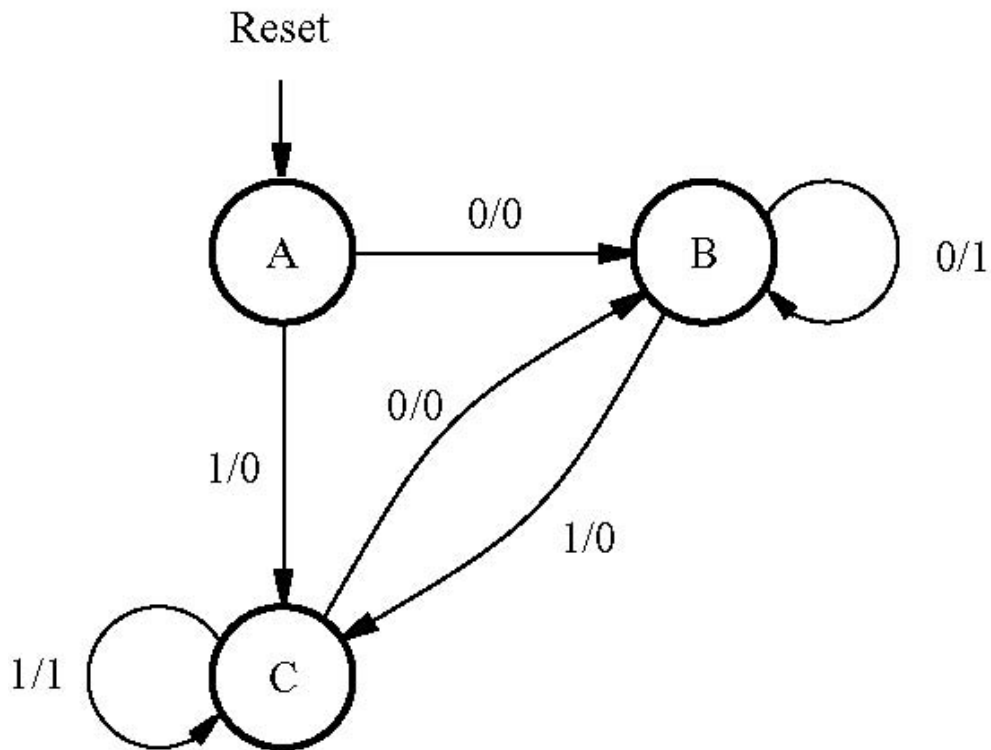

Present state	Next state		Output $z$	
	$w = 0$	$w = 1$	$w = 0$	$w = 1$
A	B	C	0	0
B	B	C	1	0
C	B	C	0	1

# State Table

Present state	Next state		Output $z$	
	$w = 0$	$w = 1$	$w = 0$	$w = 1$
A	B	C	0	0
B	B	C	1	0
C	B	C	0	1



# Building the State-Assigned Table

Present state	Next state		Output $z$	
	$w = 0$	$w = 1$	$w = 0$	$w = 1$
A	B	C	0	0
B	B	C	1	0
C	B	C	0	1

	Present state	Next state		Output	
		$w = 0$	$w = 1$	$w = 0$	$w = 1$
	$y_2y_1$	$Y_2Y_1$	$Y_2Y_1$	$z$	$z$
A	00	01	11	0	0
B	01	01	11	1	0
C	11	01	11	0	1

# State-Assigned Table

	Present state	Next state		Output	
		$w = 0$	$w = 1$	$w = 0$	$w = 1$
	$y_2y_1$	$Y_2Y_1$	$Y_2Y_1$	$z$	$z$
A	00	01	11	0	0
B	01	01	11	1	0
C	11	01	11	0	1

# State-Assigned Table

	Present state	Next state		Output	
		$w = 0$	$w = 1$	$w = 0$	$w = 1$
	$y_2y_1$	$Y_2Y_1$	$Y_2Y_1$	$z$	$z$
A	00	01	11	0	0
B	01	01	11	1	0
C	11	01	11	0	1

cut here

# State-Assigned Table

	Present state	Next state		Output	
		$w = 0$	$w = 1$	$w = 0$	$w = 1$
	$y_2y_1$	$Y_2Y_1$	$Y_2Y_1$	$z$	$z$
A	00	01	11	0	0
B	01	01	11	1	0
C	11	01	11	0	1

# State-Assigned Table

	Present state	Next state		Output	
		$w = 0$	$w = 1$	$w = 0$	$w = 1$
	$y_2y_1$	$Y_2Y_1$	$Y_2Y_1$	$z$	$z$
A	00	01	11	0	0
B	01	01	11	1	0
	10	d d	d d	d	d
C	11	01	11	0	1

# Truth Table for $Y_2$ , $Y_1$ , and $z$

	Present state	Next state		Output	
		$w = 0$	$w = 1$	$w = 0$	$w = 1$
	$y_2y_1$	$Y_2Y_1$	$Y_2Y_1$	$z$	$z$
A	00	01	11	0	0
B	01	01	11	1	0
	10	<b>dd</b>	<b>dd</b>	<b>d</b>	<b>d</b>
C	11	01	11	0	1

$w$	$y_2$	$y_1$	$Y_2$	$Y_1$	$z$
0	0	0	0	1	0
0	0	1	0	1	1
0	1	0	d	d	d
0	1	1	0	1	0
1	0	0	1	1	0
1	0	1	1	1	0
1	1	0	d	1	d
1	1	1	1	1	1

# K-Maps for $Y_2$ , $Y_1$ , and $z$

$Y_2$

$y_1$	$w y_2$	00	01	11	10
0		0	d	d	1
1		0	0	1	1

$Y_1$

$y_1$	$w y_2$	00	01	11	10
0		1	d	1	1
1		1	1	1	1

$z$

$y_1$	$w y_2$	00	01	11	10
0		0	d	d	0
1		1	0	1	0

$w$	$y_2$	$y_1$	$Y_2$	$Y_1$	$z$
0	0	0	0	1	0
0	0	1	0	1	1
0	1	0	d	d	d
0	1	1	0	1	0
1	0	0	1	1	0
1	0	1	1	1	0
1	1	0	d	1	d
1	1	1	1	1	1

# K-Maps for $Y_2$ , $Y_1$ , and $z$

$Y_2$

	$w y_2$				
$y_1$		00	01	11	10
0		0	d	d	1
1		0	0	1	1

$$Y_2 = w$$

$Y_1$

	$w y_2$				
$y_1$		00	01	11	10
0		1	d	1	1
1		1	1	1	1

$$Y_1 = 1$$

$z$

	$w y_2$				
$y_1$		00	01	11	10
0		0	d	d	0
1		1	0	1	0

$$z = \bar{w} y_1 \bar{y}_2 + w y_2$$

$w$	$y_2$	$y_1$	$Y_2$	$Y_1$	$z$
0	0	0	0	1	0
0	0	1	0	1	1
0	1	0	d	d	d
0	1	1	0	1	0
1	0	0	1	1	0
1	0	1	1	1	0
1	1	0	d	1	d
1	1	1	1	1	1



# State-Assigned Table

	Present state	Next state		Output	
		$w = 0$	$w = 1$	$w = 0$	$w = 1$
	$y_2y_1$	$Y_2Y_1$	$Y_2Y_1$	$z$	$z$
A	00	01	11	0	0
B	01	01	11	1	0
C	11	01	11	0	1

$$Y_1 = 1$$

$$Y_2 = w$$

$$z = \bar{w} y_1 \bar{y}_2 + w y_2$$

# State-Assigned Table

	Present state	Next state		Output	
		$w = 0$	$w = 1$	$w = 0$	$w = 1$
	$y_2y_1$	$Y_2Y_1$	$Y_2Y_1$	$z$	$z$
A	00	01	11	0	0
B	01	01	11	1	0
C	11	01	11	0	1

~~$$Y_1 = 1$$~~

$$Y_2 = w$$

~~$$z = \bar{w} y_1 \bar{y}_2 + w y_2$$~~

# The Circuit Diagram

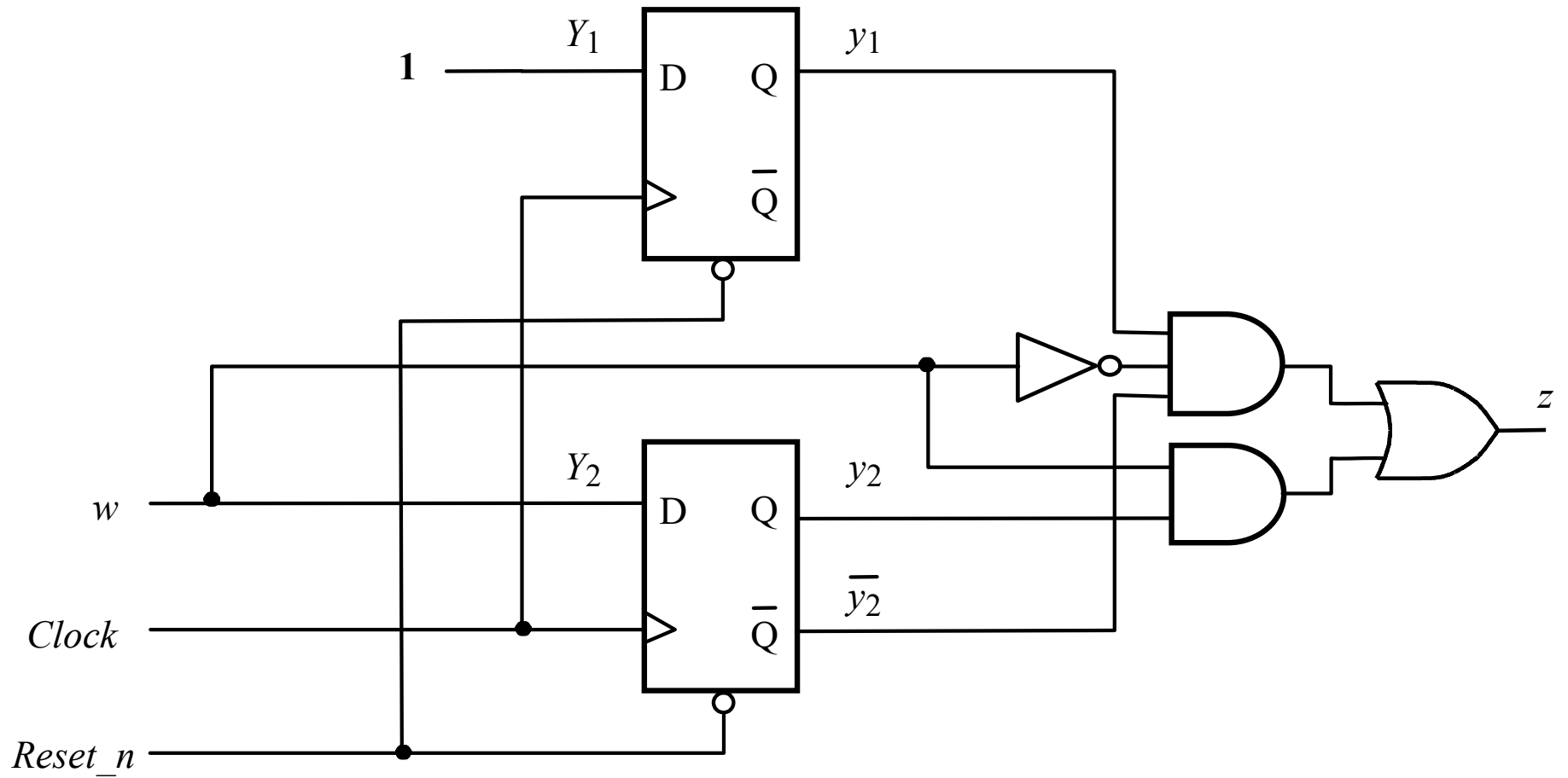

# The Circuit Diagram

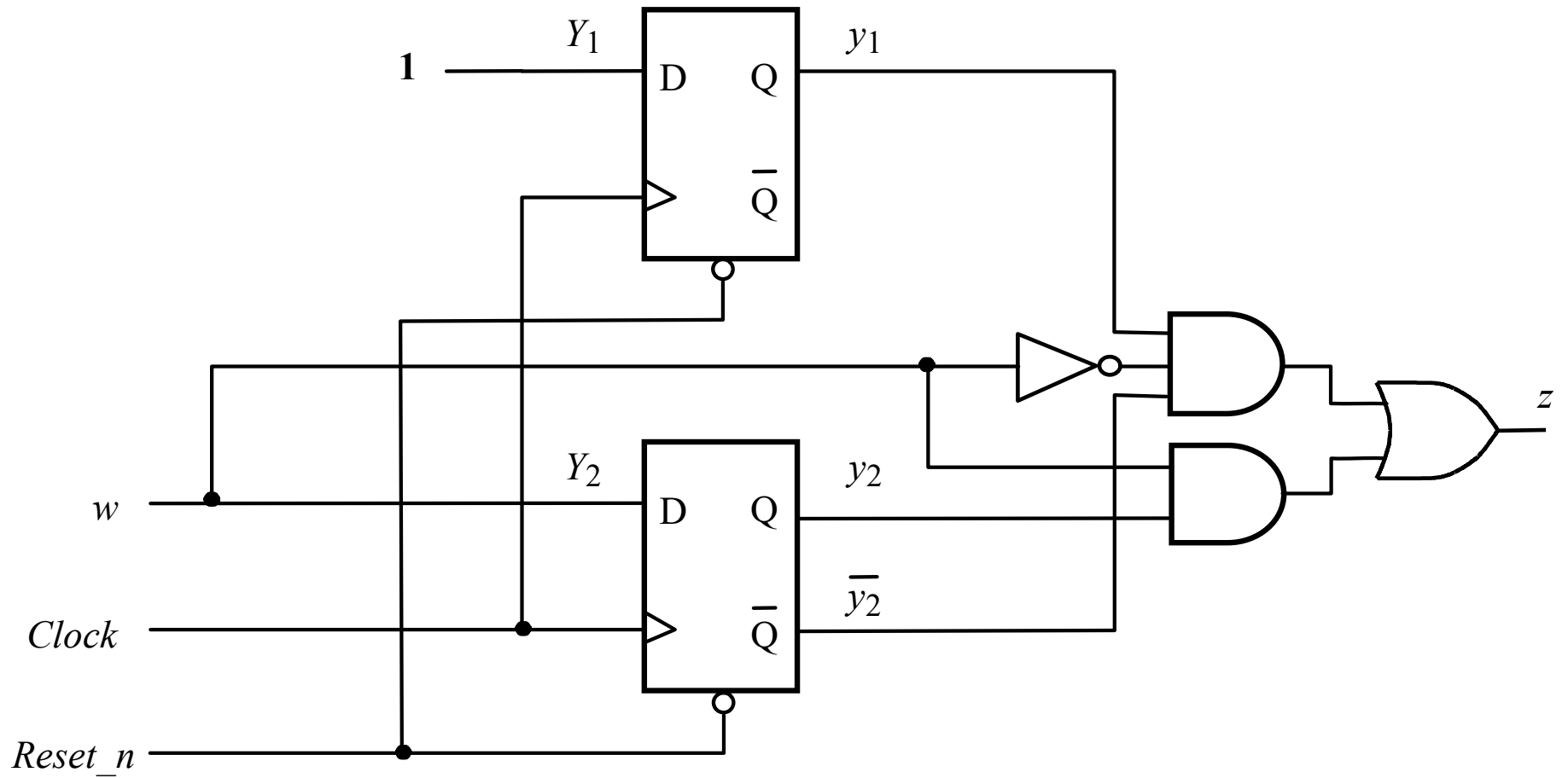

$$Y_1 = 1$$

$$Y_2 = w$$

$$z = \bar{w} y_1 \bar{y}_2 + w y_2$$

# The Circuit Diagram

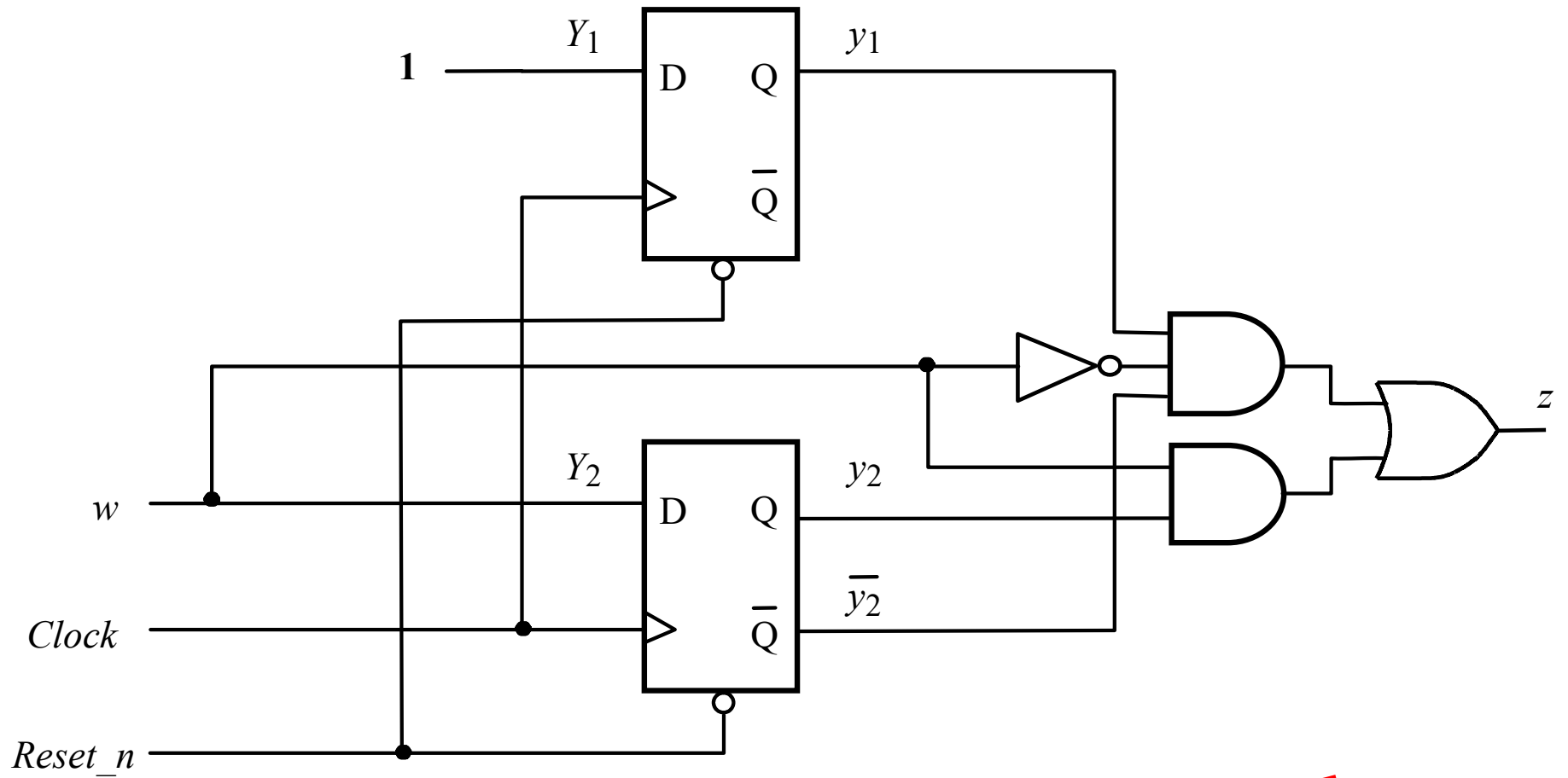

$$\begin{aligned} \cancel{Y_1} &= 1 \\ Y_2 &= w \\ z &= \bar{w} \cancel{y_1} \bar{y}_2 + w y_2 \end{aligned}$$

# The Circuit Diagram

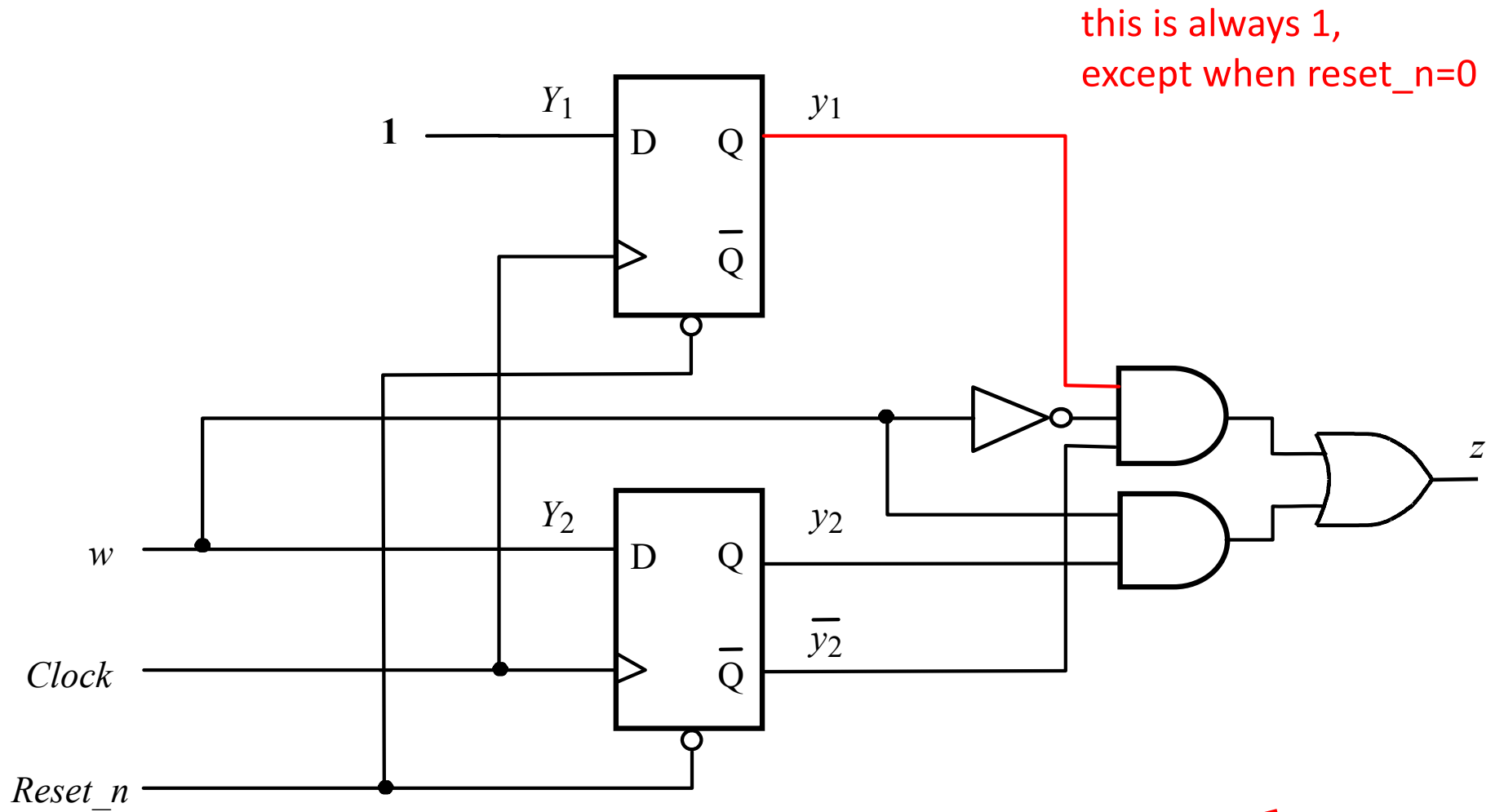

this is always 1,  
except when reset\_n=0

$$\begin{aligned} \cancel{Y_1} &= 1 \\ Y_2 &= w \\ z &= \overline{w} \cancel{y_1} \overline{y_2} + w y_2 \end{aligned}$$

# The Simplified Circuit Diagram

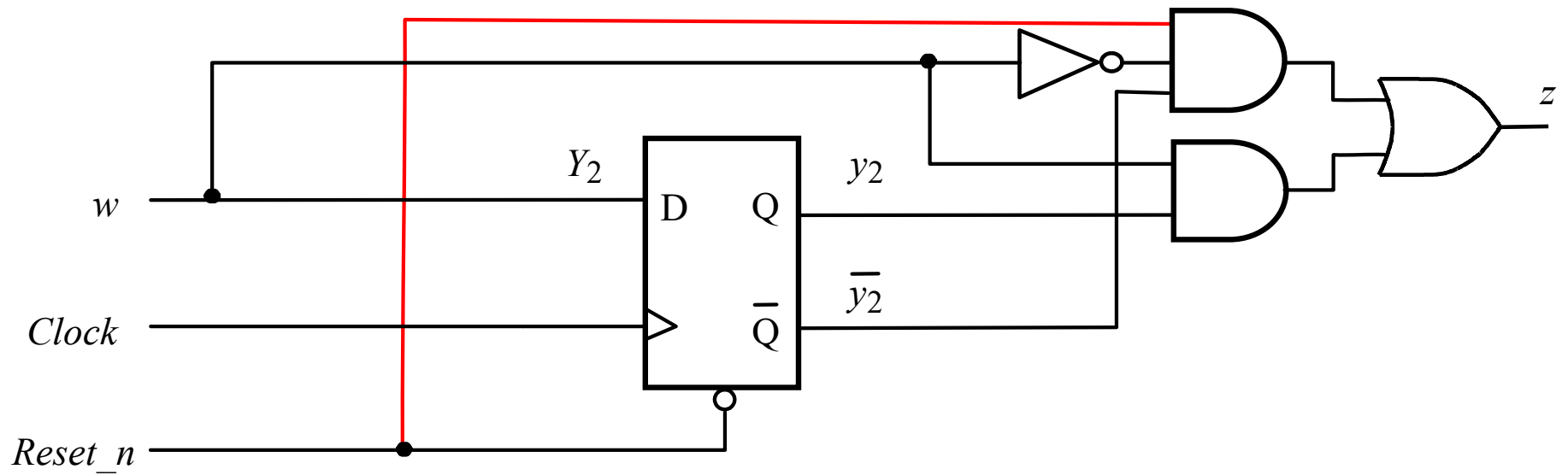

$$Y_2 = w$$
$$z = \overline{w} \overline{y_2} + w y_2$$

# Original State Diagram

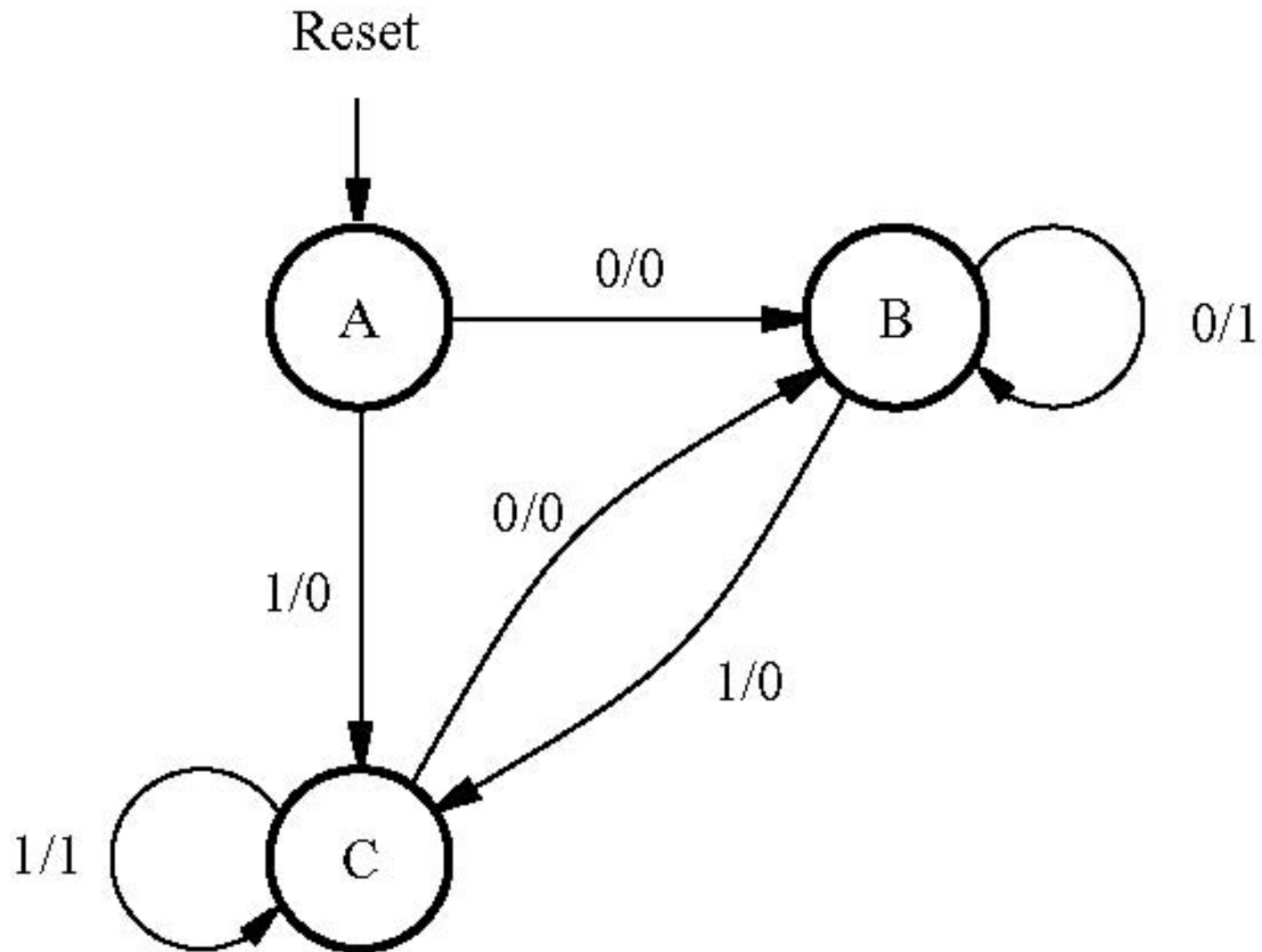



# New State Diagram

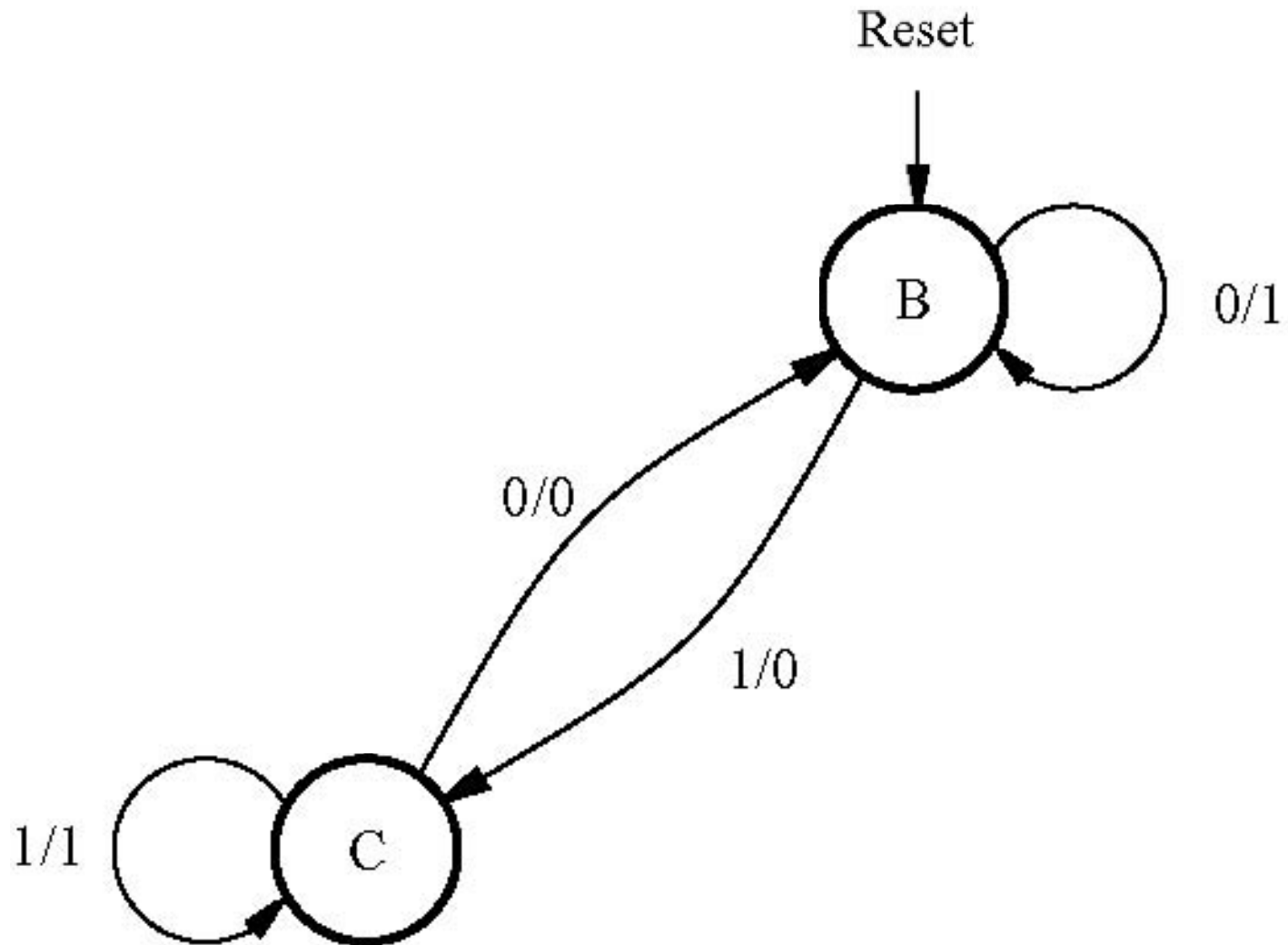

# **Example 6.15**

# Goal

Implement this state-assigned Table using JK flip-flops

	Present state $y_3y_2y_1$	Next state		Output $z$
		$w = 0$	$w = 1$	
		$Y_3Y_2Y_1$	$Y_3Y_2Y_1$	
A	000	100	110	0
B	100	101	110	0
C	101	101	110	1
D	110	100	111	0
E	111	100	111	1

# Excitation table with JK flip-flops

	Present state $y_3y_2y_1$	Flip-flop inputs								Output $z$
		$w = 0$				$w = 1$				
		$Y_3Y_2Y_1$	$J_3K_3$	$J_2K_2$	$J_1K_1$	$Y_3Y_2Y_1$	$J_3K_3$	$J_2K_2$	$J_1K_1$	
A	000	100	$1d$	$0d$	$0d$	110	$1d$	$1d$	$0d$	0
B	100	101	$d0$	$0d$	$1d$	110	$d0$	$1d$	$0d$	0
C	101	101	$d0$	$0d$	$d0$	110	$d0$	$1d$	$d1$	1
D	110	100	$d0$	$d1$	$0d$	111	$d0$	$d0$	$1d$	0
E	111	100	$d0$	$d1$	$d1$	111	$d0$	$d0$	$d0$	1

$Q(t) \rightarrow Q(t+1)$	<b>J K</b>
<b>0 → 0</b>	<b>0 d</b>
<b>0 → 1</b>	<b>1 d</b>
<b>1 → 0</b>	<b>d 1</b>
<b>1 → 1</b>	<b>d 0</b>

[ Figure 6.94 from the textbook ]

# Excitation table with JK flip-flops

	Present state $y_3y_2y_1$	Flip-flop inputs							Output $z$	
		$w = 0$				$w = 1$				
		$Y_3Y_2Y_1$	$J_3K_3$	$J_2K_2$	$J_1K_1$	$Y_3Y_2Y_1$	$J_3K_3$	$J_2K_2$		$J_1K_1$
A	000	100	1d	0d	0d	110	1d	1d	0d	0
B	100	101	d0	0d	1d	110	d0	1d	0d	0
C	101	101	d0	0d	d0	110	d0	1d	d1	1
D	110	100	d0	d1	0d	111	d0	d0	1d	0
E	111	100	d0	d1	d1	111	d0	d0	d0	1

$Q(t) \rightarrow Q(t+1)$	<b>J K</b>
0 → 0	0 d
0 → 1	1 d
1 → 0	d 1
1 → 1	d 0

# Excitation table with JK flip-flops

	Present state $y_3y_2y_1$	Flip-flop inputs							Output $z$	
		$w = 0$				$w = 1$				
		$Y_3Y_2Y_1$	$J_3K_3$	$J_2K_2$	$J_1K_1$	$Y_3Y_2Y_1$	$J_3K_3$	$J_2K_2$		$J_1K_1$
A	000	100	1 <i>d</i>	0 <i>d</i>	0 <i>d</i>	110	1 <i>d</i>	1 <i>d</i>	0 <i>d</i>	0
B	100	101	<i>d</i> 0	0 <i>d</i>	1 <i>d</i>	110	<i>d</i> 0	1 <i>d</i>	0 <i>d</i>	0
C	101	101	<i>d</i> 0	0 <i>d</i>	<i>d</i> 0	110	<i>d</i> 0	1 <i>d</i>	<i>d</i> 1	1
D	110	100	<i>d</i> 0	<i>d</i> 1	0 <i>d</i>	111	<i>d</i> 0	<i>d</i> 0	1 <i>d</i>	0
E	111	100	<i>d</i> 0	<i>d</i> 1	<i>d</i> 1	111	<i>d</i> 0	<i>d</i> 0	<i>d</i> 0	1

$Q(t) \rightarrow Q(t+1)$	J K
0 → 0	0 d
0 → 1	1 d
1 → 0	d 1
1 → 1	d 0

# Excitation table with JK flip-flops

	Present state $y_3y_2y_1$	Flip-flop inputs							Output $z$	
		$w = 0$				$w = 1$				
		$Y_3Y_2Y_1$	$J_3K_3$	$J_2K_2$	$J_1K_1$	$Y_3Y_2Y_1$	$J_3K_3$	$J_2K_2$		$J_1K_1$
A	000	100	1 <i>d</i>	0 <i>d</i>	0 <i>d</i>	110	1 <i>d</i>	1 <i>d</i>	0 <i>d</i>	0
B	100	101	<i>d</i> 0	0 <i>d</i>	1 <i>d</i>	110	<i>d</i> 0	1 <i>d</i>	0 <i>d</i>	0
C	101	101	<i>d</i> 0	0 <i>d</i>	<i>d</i> 0	110	<i>d</i> 0	1 <i>d</i>	<i>d</i> 1	1
D	110	100	<i>d</i> 0	<i>d</i> 1	0 <i>d</i>	111	<i>d</i> 0	<i>d</i> 0	1 <i>d</i>	0
E	111	100	<i>d</i> 0	<i>d</i> 1	<i>d</i> 1	111	<i>d</i> 0	<i>d</i> 0	<i>d</i> 0	1

$Q(t) \rightarrow Q(t+1)$	J K
0 → 0	0 d
0 → 1	1 d
1 → 0	d 1
1 → 1	d 0

# Excitation table with JK flip-flops

	Present state $y_3y_2y_1$	Flip-flop inputs							Output $z$	
		$w = 0$				$w = 1$				
		$Y_3Y_2Y_1$	$J_3K_3$	$J_2K_2$	$J_1K_1$	$Y_3Y_2Y_1$	$J_3K_3$	$J_2K_2$		$J_1K_1$
A	000	100	$1d$	$0d$	$0d$	110	$1d$	$1d$	$0d$	0
B	100	101	$d0$	$0d$	$1d$	110	$d0$	$1d$	$0d$	0
C	101	101	$d0$	$0d$	$d0$	110	$d0$	$1d$	$d1$	1
D	110	100	$d0$	$d1$	$0d$	111	$d0$	$d0$	$1d$	0
E	111	100	$d0$	$d1$	$d1$	111	$d0$	$d0$	$d0$	1

$Q(t) \rightarrow Q(t+1)$	<b>J K</b>
<b>0</b> → <b>0</b>	<b>0 d</b>
<b>0</b> → <b>1</b>	<b>1 d</b>
<b>1</b> → <b>0</b>	<b>d 1</b>
<b>1</b> → <b>1</b>	<b>d 0</b>



# Excitation table with JK flip-flops

	Present state $y_3y_2y_1$	Flip-flop inputs							Output $z$	
		$w = 0$				$w = 1$				
		$Y_3Y_2Y_1$	$J_3K_3$	$J_2K_2$	$J_1K_1$	$Y_3Y_2Y_1$	$J_3K_3$	$J_2K_2$		$J_1K_1$
A	000	100	1 <i>d</i>	0 <i>d</i>	0 <i>d</i>	110	1 <i>d</i>	1 <i>d</i>	0 <i>d</i>	0
B	100	101	<i>d</i> 0	0 <i>d</i>	1 <i>d</i>	110	<i>d</i> 0	1 <i>d</i>	0 <i>d</i>	0
C	101	101	<i>d</i> 0	0 <i>d</i>	<i>d</i> 0	110	<i>d</i> 0	1 <i>d</i>	<i>d</i> 1	1
D	110	100	<i>d</i> 0	<i>d</i> 1	0 <i>d</i>	111	<i>d</i> 0	<i>d</i> 0	1 <i>d</i>	0
E	111	100	<i>d</i> 0	<i>d</i> 1	<i>d</i> 1	111	<i>d</i> 0	<i>d</i> 0	<i>d</i> 0	1

$Q(t) \rightarrow Q(t+1)$	J K
0 → 0	0 d
0 → 1	1 d
1 → 0	d 1
1 → 1	d 0

# Excitation table with JK flip-flops

	Present state $y_3y_2y_1$	Flip-flop inputs							Output $z$	
		$w = 0$				$w = 1$				
		$Y_3Y_2Y_1$	$J_3K_3$	$J_2K_2$	$J_1K_1$	$Y_3Y_2Y_1$	$J_3K_3$	$J_2K_2$		$J_1K_1$
A	000	100	1d	0d	0d	110	1d	1d	0d	0
B	100	101	d0	0d	1d	110	d0	1d	0d	0
C	101	101	d0	0d	d0	110	d0	1d	d1	1
D	110	100	d0	d1	0d	111	d0	d0	1d	0
E	111	100	d0	d1	d1	111	d0	d0	d0	1

$Q(t) \rightarrow Q(t+1)$	J K
0 → 0	0 d
0 → 1	1 d
1 → 0	d 1
1 → 1	d 0

# Excitation table with JK flip-flops

	Present state $y_3y_2y_1$	Flip-flop inputs							Output $z$	
		$w = 0$				$w = 1$				
		$Y_3Y_2Y_1$	$J_3K_3$	$J_2K_2$	$J_1K_1$	$Y_3Y_2Y_1$	$J_3K_3$	$J_2K_2$		$J_1K_1$
A	000	100	1 <i>d</i>	0 <i>d</i>	0 <i>d</i>	110	1 <i>d</i>	1 <i>d</i>	0 <i>d</i>	0
B	100	101	<i>d</i> 0	0 <i>d</i>	1 <i>d</i>	110	<i>d</i> 0	1 <i>d</i>	0 <i>d</i>	0
C	101	101	<i>d</i> 0	0 <i>d</i>	<i>d</i> 0	110	<i>d</i> 0	1 <i>d</i>	<i>d</i> 1	1
D	110	100	<i>d</i> 0	<i>d</i> 1	0 <i>d</i>	111	<i>d</i> 0	<i>d</i> 0	1 <i>d</i>	0
E	111	100	<i>d</i> 0	<i>d</i> 1	<i>d</i> 1	111	<i>d</i> 0	<i>d</i> 0	<i>d</i> 0	1

$Q(t) \rightarrow Q(t+1)$	J K
0 → 0	0 <i>d</i>
0 → 1	1 <i>d</i>
1 → 0	<i>d</i> 1
1 → 1	<i>d</i> 0

And so on...

# The Expression for z

	Present state $y_3y_2y_1$	Flip-flop inputs							Output $z$	
		$w = 0$				$w = 1$				
		$Y_3Y_2Y_1$	$J_3K_3$	$J_2K_2$	$J_1K_1$	$Y_3Y_2Y_1$	$J_3K_3$	$J_2K_2$		$J_1K_1$
A	000	100	1d	0d	0d	110	1d	1d	0d	0
B	100	101	d0	0d	1d	110	d0	1d	0d	0
C	101	101	d0	0d	d0	110	d0	1d	d1	1
D	110	100	d0	d1	0d	111	d0	d0	1d	0
E	111	100	d0	d1	d1	111	d0	d0	d0	1

**z is equal to  $y_1$**

# The Expression for $J_3$

	Present state $y_3y_2y_1$	Flip-flop inputs							Output $z$	
		$w = 0$			$w = 1$					
		$Y_3Y_2Y_1$	$J_3K_3$	$J_2K_2$	$J_1K_1$	$Y_3Y_2Y_1$	$J_3K_3$	$J_2K_2$		$J_1K_1$
A	000	100	1d	0d	0d	110	1d	1d	0d	0
B	100	101	d0	0d	1d	110	d0	1d	0d	0
C	101	101	d0	0d	d0	110	d0	1d	d1	1
D	110	100	d0	d1	0d	111	d0	d0	1d	0
E	111	100	d0	d1	d1	111	d0	d0	d0	1

$J_3$  is equal to 1

# The Expression for $K_3$

	Present state $y_3y_2y_1$	Flip-flop inputs								Output $z$
		$w = 0$				$w = 1$				
		$Y_3Y_2Y_1$	$J_3K_3$	$J_2K_2$	$J_1K_1$	$Y_3Y_2Y_1$	$J_3K_3$	$J_2K_2$	$J_1K_1$	
A	000	100	1d	0d	0d	110	1d	1d	0d	0
B	100	101	d0	0d	1d	110	d0	1d	0d	0
C	101	101	d0	0d	d0	110	d0	1d	d1	1
D	110	100	d0	d1	0d	111	d0	d0	1d	0
E	111	100	d0	d1	d1	111	d0	d0	d0	1

$K_3$  is equal to 0

# The Expression for $J_2$

	Present state $y_3y_2y_1$	Flip-flop inputs							Output $z$	
		$w = 0$			$w = 1$					
		$Y_3Y_2Y_1$	$J_3K_3$	$J_2K_2$	$J_1K_1$	$Y_3Y_2Y_1$	$J_3K_3$	$J_2K_2$		$J_1K_1$
A	000	100	$1d$	$0d$	$0d$	110	$1d$	$1d$	$0d$	0
B	100	101	$d0$	$0d$	$1d$	110	$d0$	$1d$	$0d$	0
C	101	101	$d0$	$0d$	$d0$	110	$d0$	$1d$	$d1$	1
D	110	100	$d0$	$d1$	$0d$	111	$d0$	$d0$	$1d$	0
E	111	100	$d0$	$d1$	$d1$	111	$d0$	$d0$	$d0$	1

$J_2$  is equal to  $w$

# The Expression for $K_2$

	Present state $y_3y_2y_1$	Flip-flop inputs							Output $z$	
		$w = 0$			$w = 1$					
		$Y_3Y_2Y_1$	$J_3K_3$	$J_2K_2$	$J_1K_1$	$Y_3Y_2Y_1$	$J_3K_3$	$J_2K_2$		$J_1K_1$
A	000	100	1d	0d	0d	110	1d	1d	0d	0
B	100	101	d0	0d	1d	110	d0	1d	0d	0
C	101	101	d0	0d	d0	110	d0	1d	d1	1
D	110	100	d0	d1	0d	111	d0	d0	1d	0
E	111	100	d0	d1	d1	111	d0	d0	d0	1

$K_2$  is equal to  $\overline{w}$



# The Expression for $J_1$

	Present state $y_3y_2y_1$	Flip-flop inputs							Output $z$	
		$w = 0$				$w = 1$				
		$Y_3Y_2Y_1$	$J_3K_3$	$J_2K_2$	$J_1K_1$	$Y_3Y_2Y_1$	$J_3K_3$	$J_2K_2$		$J_1K_1$
A	000	100	1d	0d	0d	110	1d	1d	0d	0
B	100	101	d0	0d	1d	110	d0	1d	0d	0
C	101	101	d0	0d	d0	110	d0	1d	d1	1
D	110	100	d0	d1	0d	111	d0	d0	1d	0
E	111	100	d0	d1	d1	111	d0	d0	d0	1

$J_1$  is equal to  $w y_2 + \bar{w} y_3 \bar{y}_2$

# The Expression for $K_1$

	Present state $y_3 y_2 y_1$	Flip-flop inputs							Output $z$	
		$w = 0$			$w = 1$					
		$Y_3 Y_2 Y_1$	$J_3 K_3$	$J_2 K_2$	$J_1 K_1$	$Y_3 Y_2 Y_1$	$J_3 K_3$	$J_2 K_2$		$J_1 K_1$
A	000	100	1d	0d	0d	110	1d	1d	0d	0
B	100	101	d0	0d	1d	110	d0	1d	0d	0
C	101	101	d0	0d	d0	110	d0	1d	d1	1
D	110	100	d0	d1	0d	111	d0	d0	1d	0
E	111	100	d0	d1	d1	111	d0	d0	d0	1

001
d

$K_1$  is equal to  $\bar{w} y_2 + w \bar{y}_2 y_1$

# All Logic Expressions

$$J_1 = wy_2 + \bar{w}y_3\bar{y}_2$$

$$K_1 = \bar{w}y_2 + wy_1\bar{y}_2$$

$$J_2 = w$$

$$K_2 = \bar{w}$$

$$J_3 = 1$$

$$K_3 = 0$$

$$z = y_1$$

**Questions?**

**THE END**